



PBL Netherlands Environmental  
Assessment Agency

# **DECARBONISATION OPTIONS FOR THE DUTCH POLYCARBONATE INDUSTRY**

**D. Mooij, M.A. Muller**

**15 March 2021**

**Updated version: 12 October 2021**



**Manufacturing Industry Decarbonisation Data Exchange Network**

## **Decarbonisation options for the Dutch polycarbonate industry**

© PBL Netherlands Environmental Assessment Agency; © TNO

The Hague, 2021

PBL publication number: 4580

TNO project no. 060.47868 / TNO 2021 P10228

### **Authors**

D. Mooij and M.A. Muller

### **Acknowledgements**

The authors are grateful to Isja Dominicus (SABIC Innovative Plastics Bergen op Zoom), Hans Eerens (PBL) and Hans Meerman (RUG/TNO) for valuable information and feedback.

### **MIDDEN project coordination and responsibility**

The MIDDEN project (Manufacturing Industry Decarbonisation Data Exchange Network) was initiated and is also coordinated and funded by PBL and TNO Energy Transition Studies. The project aims to support industry, policymakers, analysts, and the energy sector in their common efforts to achieve deep decarbonisation. Correspondence regarding the project may be addressed to: D. van Dam (PBL), Dick.vanDam@pbl.nl or S. Gamboa Palacios (TNO), silvana.gamboapalacios@tno.nl.

This publication is a joint publication by PBL and TNO EnergieTransitie and can be downloaded from: [www.pbl.nl/en](http://www.pbl.nl/en). Parts of this publication may be reproduced, providing the source is stated, in the form: Mooij, D. and Muller, M. (2021), Decarbonisation options for the Dutch polycarbonate industry. PBL Netherlands Environmental Assessment Agency and TNO EnergieTransitie, The Hague.

PBL Netherlands Environmental Assessment Agency is the national institute for strategic policy analysis in the fields of the environment, nature and spatial planning. PBL contributes to improving the quality of political and administrative decision-making by conducting outlook studies, analyses and evaluations in which an integrated approach is considered paramount. Policy relevance is the prime concern in all of PBL's studies. PBL conducts solicited and unsolicited research that is both independent and scientifically sound.

TNO EnergieTransitie has a twofold mission: to accelerate the energy transition and to strengthen the competitive position of the Netherlands. TNO conducts independent and internationally leading research and we stand for an agenda-setting, initiating and supporting role for government, industry and NGOs.

This report was reviewed by SABIC Innovative Plastics Bergen op Zoom. PBL and TNO remain responsible for the content. The decarbonisation options and parameters are explicitly not verified by the companies.

### **Erratum**

In this version a sentence was removed on page 38, since the information was not completely accurate and deemed not relevant for this report.

# Contents

Summary	4
<b>INTRODUCTION</b>	<b>5</b>
<b>1 POLYCARBONATE MANUFACTURING IN THE NETHERLANDS</b>	<b>6</b>
1.1 Saudi Basic Industries Corporation	6
1.2 SABIC Innovative Plastics Bergen op Zoom	7
<b>2 PRODUCTION PROCESSES</b>	<b>12</b>
2.1 Overview	12
2.2 Polycarbonate production	12
2.3 Compounding/extrusion plants	22
2.4 Material and Energy Flow Analysis	24
<b>3 PRODUCTS AND APPLICATION</b>	<b>26</b>
3.1 Lexan polycarbonate	26
3.2 Other engineering thermoplastics	28
<b>4 OPTIONS FOR DECARBONISATION</b>	<b>29</b>
4.1 Fuel substitution	29
4.2 Feedstock substitution	36
4.3 Process design	38
4.4 Recycling	39
4.5 Product design	40
4.6 Use of residual energy	41
4.7 CO <sub>2</sub> capture and storage or re-use	41
<b>5 DISCUSSION</b>	<b>43</b>
<b>6 REFERENCES</b>	<b>45</b>
<b>APPENDIX A</b>	<b>50</b>

# FINDINGS

## Summary

In the Netherlands polycarbonate is produced by SABIC Innovative Plastics Bergen op Zoom (SABIC IP BoZ). SABIC IP BoZ sells polycarbonate in a pure powder form (PC Resin) and in compounded form under the name Lexan. Polymer blends, containing polycarbonate but also other polymers, are also produced at the site and are used for a wide variety of applications and end-products. The Netherlands produces about 20% of the total European polycarbonate production, generating about 490 million euro of value added yearly. The polycarbonate consumption is dominated by four main sectors: Building and Construction, Electrical & Electronics industries, Optical Media and Automotive.

Polycarbonate production starts with the synthesis of the building blocks that make up the polymer structure: phosgene and bisphenol A (BPA). Chlorine, required for phosgene production is also produced on-site by electrolysis of sodium chloride. Electrolysis is an energy-intensive process. In the production of bisphenol A and polycarbonate powder a number of steam intensive separation and purification steps are required to make sure the produced polycarbonate powder is of high purity. Part of the polycarbonate powder is sold as PC Resin and another part is processed further in the compounding plants to Lexan or polycarbonate containing polymer blends. In the compounding plants, the polymer powders are mixed with other polymers, additives and pigments to tune the final properties and moulded to their final form. The compounding plants mainly use electricity. To produce one tonne of compounded polycarbonate about 18 GJ of energy is required, resulting in 1.1 tonne of CO<sub>2</sub> emissions. For the total production of 239 thousand tonnes (kt) polycarbonate powder, the energy requirements add up to 3.7 PJ. Additionally, 0.5 PJ of energy is needed for compounding.

According to the Dutch Emission Authority, a total of 195,074 tonnes of CO<sub>2</sub> (direct emissions) was emitted at the site in 2019. The indirect emissions (related to imported electricity) were estimated to be 66,650 tonnes of CO<sub>2</sub> in 2018. The greenhouse gas emissions of SABIC Innovative Plastics result from the burning of natural gas in a combined heat and power plant (CHP) for steam and electricity generation. Hence, many of the decarbonisation options identified in this work aim to decarbonise the energy supply. Fuel substitution technologies enabling the decarbonisation of SABIC's steam supply include the use of an electrode boiler, the combustion of biomass, hydrogen combustion and geothermal energy. Prerequisites for these decarbonisation technologies include the availability of renewable electricity and sustainably sourced biomass. Technologies such as mechanical vapour recompression and zero-gap electrolysers could be employed to increase the energy efficiency of current processes and lower the total energy demand. Alternatively or in addition, the current fossil feedstocks could be replaced by bio-based feedstocks enabling emission reductions along the polycarbonate value chain. Further emission reduction can be achieved through recycling of polycarbonate products.

## FULL RESULTS

# Introduction

This report describes the current situation for polycarbonate production in the Netherlands and the options and preconditions for its decarbonisation. The study is part of the MIDDEN project (Manufacturing Industry Decarbonisation Data Exchange Network). The MIDDEN project aims to support industry, policymakers, analysts, and the energy sector in their common efforts to achieve deep decarbonisation. The MIDDEN project will update and elaborate further on options in the future, in close connection with the industry. The emissions addressed in the study are those falling under scope 1 (direct emissions on-site) and scope 2 (related to imported electricity).

## Scope

In the Netherlands, SABIC Innovative Plastics Bergen op Zoom is the only large-scale polycarbonate producer.

Production processes include chlorine production by electrolysis, phosgene production from chlorine and carbon monoxide, bisphenol A production from acetone and phenol, polycarbonate resin production by the interfacial polycondensation of bisphenol A and phosgene and compounding and extrusion processes; products include: polycarbonate resin, Lexan polycarbonate and polycarbonate blends Cycology, Xenoy and Valox.

The main options for decarbonisation aim at substituting the steam supply and include the use of biomass as fuel, electrification, hydrogen combustion and ultra-deep geothermal energy. Energy efficiency improvements are to be gained from the use of zero-gap membrane electrolysers and mechanical vapour recompression. The use of biomass or CO<sub>2</sub> as feedstock and recycling could also decarbonise polycarbonate production.

## Reading guide

Section 1 introduces the Dutch polycarbonate industry. Section 2 describes the current situation for polycarbonate production processes in the Netherlands, and Section 3 describes the relevant products of these processes, while options for decarbonisation are systematically quantified and evaluated in Section 4. The feasibility of and requirements for those decarbonisation options are discussed in Section 5.

# 1 Polycarbonate manufacturing in the Netherlands

The Dutch polycarbonate manufacturing industry is centered around SABIC Innovative Plastics located in Bergen op Zoom. In this chapter, a description is given of the company and its processes as well as the current and historical CO<sub>2</sub> emissions. At the production site of SABIC Bergen op Zoom, polycarbonate powders and resins are produced that can be used for a wide variety of applications and end-products. An overview of the products and end-users is given in chapter 3.

## 1.1 Saudi Basic Industries Corporation

The Saudi Basic Industries Corporation (SABIC) was founded in Saudi Arabia in 1976 by Royal decree for the production of chemicals from oil by-products. With an annual sales revenue of 33 billion euros, the company is one of the largest chemical companies in the world, employing more than 33,000 people in 50 countries. The state-owned oil concern Saudi Aramco is SABIC's majority shareholder owning 70% of the shares. The remaining shares are controlled by institutions and private investors. SABIC's headquarters are located in Riyadh, Saudi Arabia (SABIC, 2019a).

SABIC is active in four main business areas; petrochemicals, specialties, agri-nutrients and metals. Petrochemicals is the largest business unit, products include basic chemicals such as methanol and olefins used in various industries. The specialties unit focusses on the development of high-performance materials designed for specific applications. Agri-nutrients produces a range of nitrogen-based fertilisers. The metal unit is controlled by Hadeed, SABIC's iron and steel company, and is the leading steel producer in the Arabian Gulf region (SABIC, 2019a).

Manufacturing sites, sales offices and research and innovation facilities are situated all over the world and managed from regional offices in the Middle East and Africa, Asia, the Americas and Europe. SABIC's European headquarters are located in Sittard, the Netherlands (SABIC, 2019a). Two of SABIC's European largest production sites are also situated in the Netherlands, in Geleen (Chemelot) and Bergen op Zoom. In Geleen (poly)olefins are produced from naphtha (SABIC Limburg, n.d.). The production of large volume organic chemicals and polyolefins in Geleen is described in detail in two MIDDEN reports: Oliveira and Van Dril (2021) and Negri and Ligthart (2021). The Bergen op Zoom site is part of the business unit Innovative Plastics that develops and produces engineering thermoplastics amongst which polycarbonate (SABIC Bergen op Zoom, n.d. (a)).

## 1.2 SABIC Innovative Plastics Bergen op Zoom

### 1.2.1 History

In 1969, GE Plastics opened a manufacturing site for the production of engineering plastics at the industrial area Theodorushaven in Bergen op Zoom. Two of GE Plastics main products are produced at the site, polycarbonate traded under the name Lexan and Noryl, a polyphenylene-oxide/polystyrene blend (Schrama, 1998). Other resins produced at the site include Cycloy, a polycarbonate and acrylonitrile-butadiene-styrene blend; Xenoy, composed of polycarbonate and polybutylene terephthalate and Valox, a polyester blend (SABIC Bergen op Zoom, n.d. (b); Coe, 2000) (Table 1). In 2007, SABIC acquired the site from GE Plastics and expanded the production of the thermoplastic resins (Dijkgraaf, 2007). Currently, SABIC Innovative Plastics Bergen op Zoom (SABIC IP BoZ) employs around 1325 employees, of which 75% work in production. Besides being an important manufacturing site, the site also houses a technology research & development department, a customer services department and offices (SABIC Bergen op Zoom, n.d. (c)). Since 2012, the SABIC Bergen op Zoom site is also home to the Green Chemistry Campus, a business accelerator for scaling up bio-circular innovations (Green Chemistry Campus, n.d.)

**Table 1: SABIC IP BoZ main products brand name, chemical name and applications.**

Brand name	Chemical name	Application	Production volume 2018 (kt)*
PC resin	Polycarbonate (PC)	High impact/light weight/stiff transparent applications (i.e. glass replacement, electrical hardware, water tank bottles etc.) & aesthetics enhancement	116
Lexan			123
Noryl	Polyphenylene oxide (PPO)/ Polystyrene (PS)	Electrical hardware, automotive (dashboard)	123
Cycloy	Polycarbonate (PC)/ Acrylonitrile-butadiene-styrene (ABS)	Ski boots, medical devices and pharmaceutical applications	
Xenoy	Polycarbonate (PC)/Polybutylene terephthalate (PBT)	Automotive exterior (bumper), hospital beds	
Valox	Polyethylene terephthalate (PET)/ Polybutylene terephthalate (PBT)/ Polycarbonate (PC)	Electronics, appliance handles and housings, sprinklers	

\* As calculated based on the energy and material flow analysis

### 1.2.2 Site overview

At the SABIC IP BoZ site there are nine manufacturing plants for the production of the plastic products. Three plants are involved in the production of the raw materials for polycarbonate; the chlorine plant, the phosgene plant and the bisphenol A (BPA) plant. In the resin plant, polycarbonate powder is synthesised from the raw materials (SABIC Innovative Plastics, 2011; Van Luijk, 2003). The polyphenylene oxide (PPO) plant is part of the Noryl production line and produces polyphenylene-ether (marketed by SABIC as polyphenylene oxide) powder, the main building block for Noryl. Due to falling demand and rising raw material

prices, SABIC closed the PPO plant in 2014. As demands have increased, the plant is currently being rebuilt and set to open in 2021 (Verbraeken, 2018; SABIC IP BoZ, Online Communication, 2020a). As the PPO plant is currently not operating and it is not involved in polycarbonate production, the Noryl line is excluded from this work. There are 4 compounding or extrusion plants that shape the plastic powders to their final form. Lexan finishing (LXF) and specialty film and sheet (SF&S) are involved in the Lexan/polycarbonate production line and produce resins and films and sheets. The Noryl plant blends the polyphenylene oxide and polystyrene to make the Noryl resins. The flexible compounding plant (FCP) is involved in the production of the blended materials such as Xenoy, Cycloy and Valox (SABIC Innovative Plastics, 2011).



**Figure 1: SABIC Innovative Plastics Bergen op Zoom production site (BlueTerra, n.d.).**

SABIC IP BoZ has two cogenerators (Combined Heat and Power plant, CHP or cogen) for the combined generation of steam and electricity from natural gas (Schrama, 1998). Currently, only one of the cogenerators is in use with the other serving as back up (SABIC IP BoZ, Online communication, 2020b). The cogenerator in use has a capacity of 132 MW (European Environment Agency, 2020). It produces 80 tonnes of steam per hour on average and operates the year round (8760 h/yr) (SABIC IP BoZ, Online communication, 2020b). Additional steam is generated by burning hydrogen in a boiler (7 tonne steam/hour) and furthermore tar is incinerated in a tar boiler/incinerator producing 10 tonne steam/hour. The site also has a biological wastewater treatment plant to clean process water and a port for the import of raw materials and export of products (SABIC Bergen op Zoom, n.d. (a); Omgevingsdienst Brabant Noord, 2016). Air Liquide provides SABIC IP BoZ with carbon monoxide and steam (25 tonne/hour) produced at its Bergen op Zoom site (DWA, 2008). The industrial production site of Air Liquide is fully integrated at the SABIC IP BoZ site. Air Liquide is connected to the international pipeline between Rotterdam and Antwerp for the distribution of nitrogen, oxygen, hydrogen and carbon monoxide (Air Liquide, n.d.). SABIC IP BoZ also has a steam and electricity connection to Cargill, a starch and sweetener producing company located in the Theodorushaven. SABIC IP BoZ exports steam (10 tonne/hour) and 3 MW of electricity to Cargill (DWA, 2008). Natural gas is supplied to the site via the Zebra network. The Theodorushaven is connected to the high voltage grid (150 kV) operated by TenneT (BlueTerra, 2019).

### 1.2.3 Greenhouse gas emissions



Being a large production site and part of the European Union Emission Trading Scheme (EU ETS) system, SABIC IP BoZ emits substantial amounts of carbon dioxide. Figure 2 shows the development of SABIC IP BoZ on-site CO<sub>2</sub> emissions over the time span 2013-2019. From the figure it becomes apparent that SABIC IP BoZ has already significantly cut its scope 1 (direct) emissions, reducing its 2013 emissions by more than half in 2019 (0.35 million tonnes (Mt) CO<sub>2</sub> in 2013 compared to 0.16 Mt CO<sub>2</sub> in 2019). The scope 1 emission reductions are likely to have resulted from the closing of plants and a cogenerator. SABIC IP BoZ used to have two BPA plants, but shut one down due to its low efficiency. As the BPA plants are energy intensive, this had a reducing effect on SABIC IP BoZ's energy use and hence CO<sub>2</sub> emissions. Further emission reductions have been achieved by the shutdown of the PPO plant in 2014, with the plant restarting in 2021 the effects of this temporary closure might become apparent. Additionally, SABIC IP BoZ stopped using one of the cogenerators and started importing electricity, this likely had a significant reducing effect on the scope 1 emissions of SABIC IP BoZ (SABIC IP BoZ, Online communication, 2020b). As the closure of a cogenerator made it necessary to import electricity, SABIC IP BoZ's scope 2 (indirect) emissions have increased since. According to SABIC IP BoZ, reuse of waste heat and heat generated in the incinerators has also contributed to scope 1 emission reductions (SABIC Bergen op Zoom, n.d. (d)). The lowering of emissions in 2019 as compared to 2018 results from a lower production capacity in 2019 due to a maintenance turnaround that stopped production for 2 months (SABIC IP BoZ, 2020c).

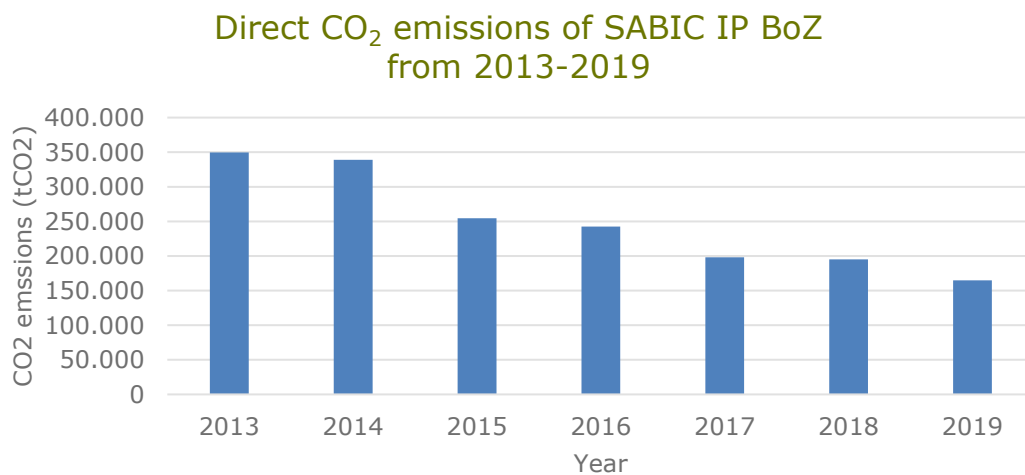

**Figure 2: Direct CO<sub>2</sub> emissions from SABIC Innovative Plastics Bergen op Zoom between 2013-2019 (NEa, 2020).**

Free emissions rights (European Emission Allowances [EUA's]) are allocated to Dutch companies that are part of the EU ETS by the Dutch Emissions Authority (Nederlandse Emissie Autoriteit [NEa]). Figure 3 shows the free emission rights allocated to SABIC IP BoZ in the time period 2013-2019. Mostly, the amount of free emission rights an EU ETS company gets allocated is determined by product benchmarks. However, for polycarbonate such a product benchmark is lacking. Instead benchmarks for heat use are used. As shown in Table 2 SABIC IP BoZ emits more CO<sub>2</sub> than they get allocated freely. This means SABIC IP BoZ is less efficient than the benchmark and thus has to pay for the additional emission rights they need to cover the total amount of CO<sub>2</sub> they emit. Therefore, to cut expenses, SABIC IP BoZ has an incentive to decarbonise.

### NEA free allocation of emission rights to SABIC IP BoZ from 2013-2019

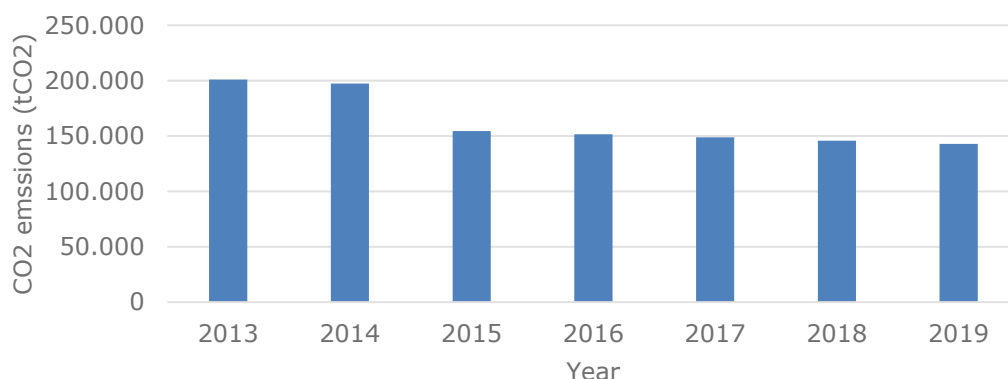
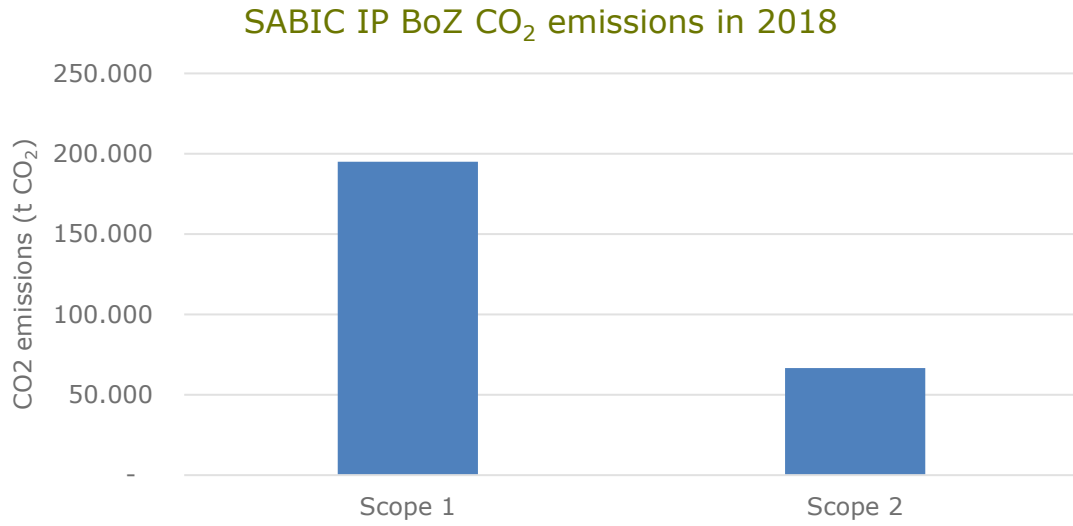

**Figure 3: Free allocation of emission rights to SABIC IP BoZ between 2013-2019 (NEa, 2020).**

**Table 2: SABIC IP BoZ registered emissions versus freely allocated emission rights.**

	2013	2014	2015	2016	2017	2018	2019
NEa Registered CO <sub>2</sub> emissions (tCO <sub>2</sub> )	349,502	339,053	254,469	242,452	198,050	195,074	164,878
NEa Free allocation of emissions rights (tCO <sub>2</sub> )	200,952	197,462	154,482	151,639	148,766	145,865	142,928
Difference (tCO <sub>2</sub> )	<b>148,550</b>	<b>141,591</b>	<b>99,987</b>	<b>90,813</b>	<b>49,284</b>	<b>49,209</b>	<b>21,950</b>

The NEa only registers on-site emissions, so is limited to the scope 1 emissions. As SABIC IP BoZ also needs to import electricity to sustain their production levels, scope 2 emissions from the use of this electricity must also be considered in this report. To estimate the scope 2 emissions, the total amount of imported electricity (0.56 PJ in 2018) is multiplied by the Dutch national electricity grid emission factor which is 0.43 kgCO<sub>2</sub>/kWh (CBS, 2020). Additionally, SABIC IP BoZ purchases steam from Air Liquide. The steam provided by Air Liquide is a waste product of the process in which CO is produced for SABIC IP BoZ. The excess heat generated in this process cannot be used by Air Liquide and is sold to SABIC IP BoZ. The heat is considered as waste heat and the CO<sub>2</sub> emissions are allocated to products of Air Liquide and therefore not included in SABIC's scope 2 emissions. Figure 4 shows the scope 1 and 2 emissions resulting from SABIC IP BoZ's production processes. As the data of imported steam and electricity was only available for the year 2018, this work takes 2018 as the year of analysis.



**Figure 4: Scope 1 and 2 CO<sub>2</sub> emissions from SABIC IP BoZ in 2018** (*SABIC IP BoZ, 2020d; NEa, 2020*).

# 2 Production processes

## 2.1 Overview

There are three main production lines of engineering plastics at SABIC IP BoZ; Lexan, Noryl and the flexible production line. Figure 5 shows an overview of the production plants. The Chlorine, Phosgene, Bisphenol A, Resin, Lexan Finishing and Specialty Film & Sheet plant are part of the Polycarbonate/Lexan production line. The Polyphenylene oxide (PPO) and Noryl plant make up the Noryl line. As this report details polycarbonate manufacturing, the Noryl line is not considered in this work. The Flexible Compounding Plant (FCP) produces various end products such as the polycarbonate blends Valox, Cycology and Xenoy. The production processes that occur in the plants will be elaborated on in the following.

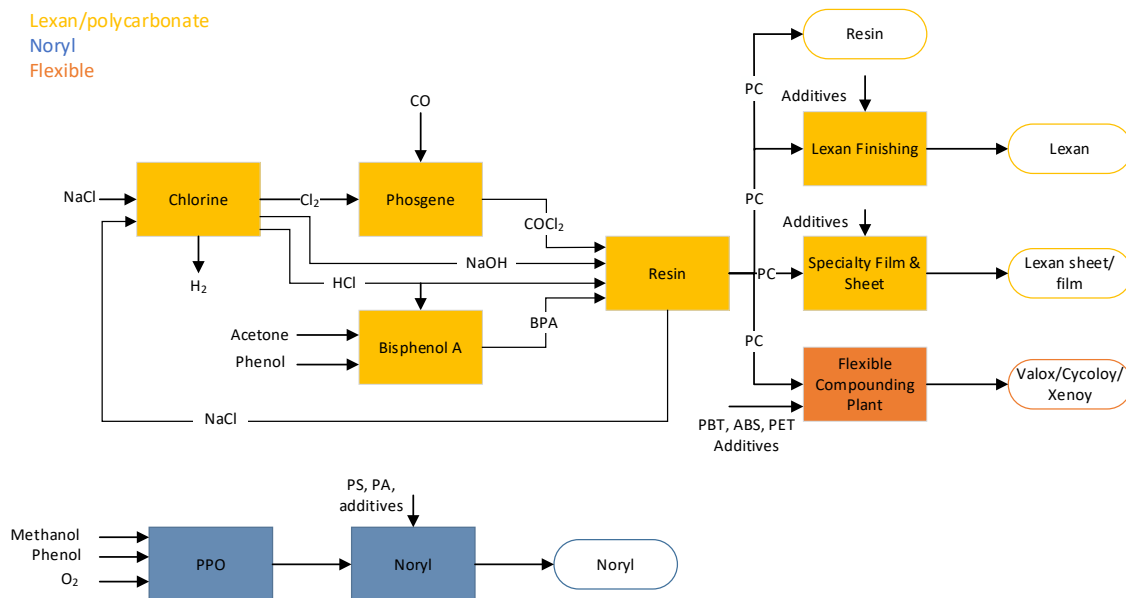

Figure 5: Overview of SABIC IP BoZ production plants.

## 2.2 Polycarbonate production

### 2.2.1 Chlorine plant

The chlorine plant at SABIC IP BoZ has previously been included in the MIDDEN report about the Dutch chlor-alkali industry and produces about 10% of the total Dutch chlorine production (Scherpbier & Eerens, 2021). As the plant's energy consumption and decarbonisation options have already been studied intensively in the chlor-alkali MIDDEN report, it will be reviewed only briefly here. Important adaptations by SABIC IP BoZ to the chlor-alkali process as described in the MIDDEN report about this sector include HCl synthesis and the use of recovered brine from the resin plant. The recovery of brine from another production plant reduces SABIC IP BoZ fresh salt consumption by around 40% (SABIC IP BoZ, Online Communication, 2020a). Figure 6 shows the production processes in the chlorine plant for the production of chlorine.

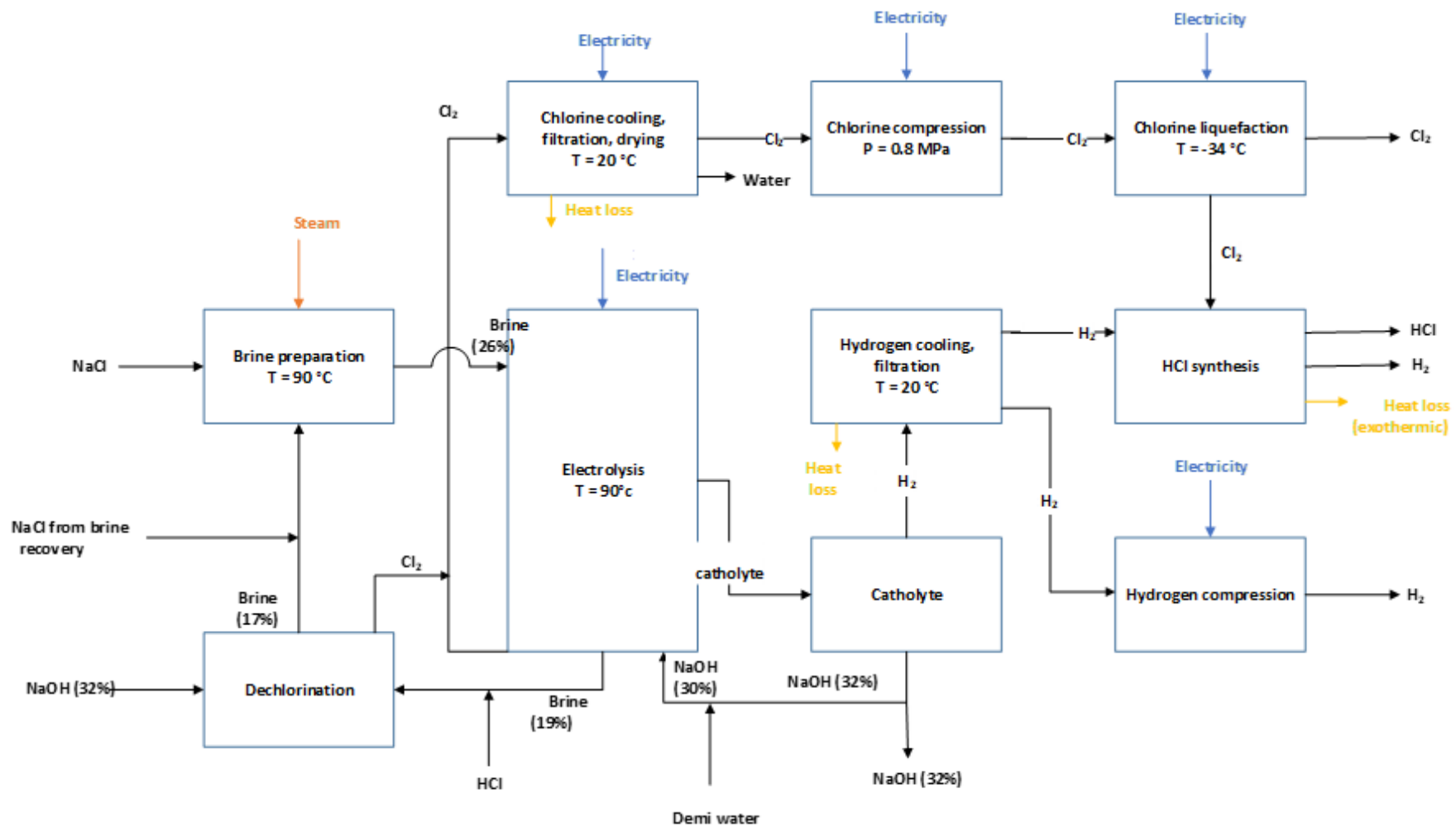
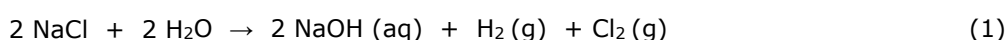

Figure 6: Mass and energy flow chart for the production of chlorine – adapted from the MIDDEN chlor-alkali report (Scherpbier & Eerens, 2021). For confidential reasons, the mass and energy numbers are not presented in this flow chart.

Like all other Dutch chlorine manufacturing plants, the chlorine plant at Bergen op Zoom is a membrane electrolysis plant that produces chlorine (Cl<sub>2</sub>), caustic soda (NaOH), hydrogen chloride (HCl) and hydrogen (H<sub>2</sub>) from brine (NaCl in water).

The process of membrane electrolysis involves an electrolytic redox cell with a positive anode and a negative cathode separated by a membrane. At the anode, the Cl<sup>-</sup> ions from brine are oxidised to Cl<sub>2</sub> gas. At the cathode, a solution of caustic soda in water is required to reduce the H<sup>+</sup> ions to form H<sub>2</sub> gas. The membrane is permeable for positive ions, resulting in the movement of the Na<sup>+</sup> ions from the anode to the cathode side, where extra caustic soda is formed. To keep the reaction balanced, the anode side depleted brine and concentrated caustic soda are drained and replaced with new brine and caustic soda. This recovery of the dechlorinated brine requires a substantial amount of heat (Scherpbier & Eerens, 2021). This heat is provided by the waste heat from the electrolyzers. Waste heat from the electrolyzers is also used to heat the caustic soda. Equation 1 shows the overall process reaction equation.



The total energy requirements for the production of 1 tonne of chlorine (l) by electrolysis are listed in Table 3. Heat loss occurs as a result of chlorine and hydrogen cooling and due to the exothermic HCl synthesis reaction.

**Table 3: Energy requirements for the production of 1 tonne of chlorine.**

Energy carrier	Input (GJ/tonne)	Source
Steam	0.90 – 1.10	(SABIC IP BoZ, 2020a)
Electricity	9.5 – 11.5	(SABIC IP BoZ, 2020a)
Heat loss	0.95 – 1.15	Calculated

### 2.2.2 Phosgene plant

In the phosgene plant, phosgene is synthesised from chlorine and carbon monoxide (CO). The chlorine produced in the chlorine plant is introduced into the phosgene plant where it is combined with carbon monoxide to yield phosgene. The carbon monoxide required for the reaction is produced by Air Liquide. As phosgene gas is highly toxic and storage risky, all phosgene produced is used to synthesise polycarbonate (Mehta, 2020). Figure 7 shows a flowchart of processes occurring in the phosgene plant. Table 4 lists the energy requirements as calculated.

**Table 4: Energy requirements for the production of 1 tonne of phosgene.**

Energy carrier	Input (GJ/tonne)	Source
Steam	0.36 – 0.44	(SABIC IP BoZ, 2020b)
Electricity	0.07 – 0.09	Calculated based on (SABIC IP BoZ, 2020a)
Heat loss	0.25 – 0.30	Calculated

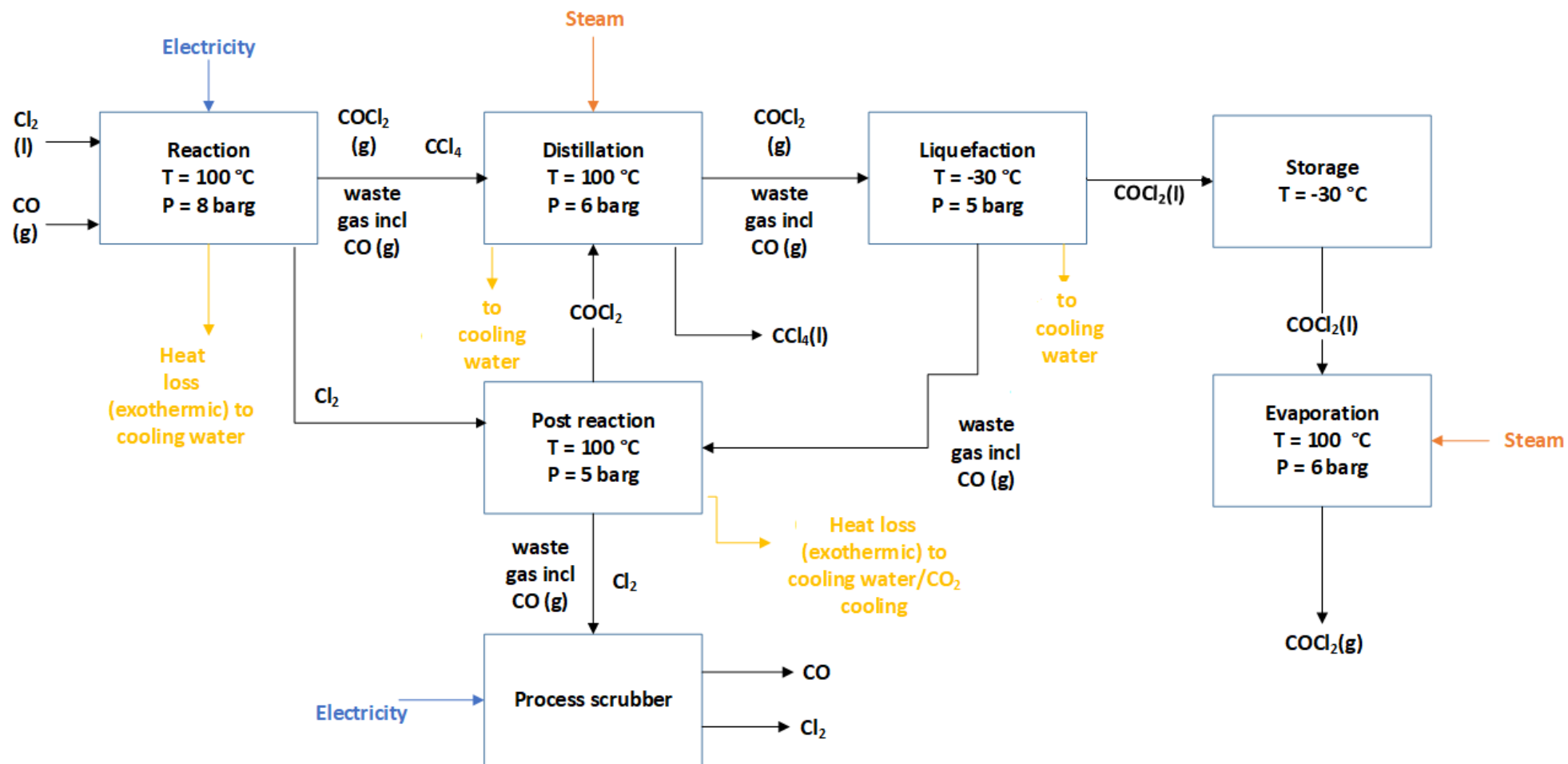

Figure 7: Mass and energy flow chart for the production of phosgene. For confidential reasons, the mass and energy numbers are not presented in this flow chart.

### **Reaction**

Chlorine is reacted with gaseous carbon monoxide over an activated carbon catalyst to form phosgene (equation 2) (Ryan, Ryan, Seddon, & Seddon, 1996). To ensure that all the chlorine reacts, a slight excess of carbon monoxide is used. To avoid the decomposition of phosgene in water and impurities, the chlorine and carbon monoxide must be of the highest purity possible (Mark, 2004). The reaction is performed in a multitubular reactor of which the tubes are filled with the activated carbon catalyst. With a reaction enthalpy of -108 kJ/mol, the reaction is exothermic (heat is generated in the process). Consequently, the reactor needs to be cooled using a cooling system. The temperature of the reactor needs to be controlled accurately as at temperatures above 250 °C phosgene decomposes into the reactants, carbon dioxide and tetrachloromethane (CCl<sub>4</sub>). Depending on the purity of the raw materials, by-products including HCl, CCl<sub>4</sub> and H<sub>2</sub>O might be formed (American Chemistry Council, 2018). The heat generated during the reaction is also used to evaporate chlorine from the liquid to the gas phase.



### **Distillation**

After the phosgene has been formed in the reactor, the next step is distillation to remove the by-product tetrachloromethane. The formation and removal of tetrachloromethane needs to be monitored carefully as tetrachloromethane influences the polycarbonate colour. High concentrations of tetrachloromethane can cause the material to turn yellowish, limiting its application for optical purposes. Additionally, tetrachloromethane has significant ozone depletion and global warming potential (Cotarca & Eckert, 2003).

### **Liquefaction**

After distillation, the phosgene is compressed and condensed with an ammonia cooling system and cooling water for storage. Waste gas containing the by-product carbon monoxide is led into the post reactor.

### **Post reaction**

In the post reaction step, unreacted chlorine from the reaction step and waste gas containing carbon monoxide from the liquefaction step are reacted to form additional phosgene that is led to the distillation step. The post reactor is cooled using a CO<sub>2</sub> cooling system as well as cooling water. Waste gas and unreacted carbon monoxide from the post reactor are scrubbed using a caustic scrubber and released to the atmosphere.

### **Evaporation**

As the phosgene needs to be in the gas phase in order to react with BPA to form polycarbonate, the liquid phosgene from the storage tanks is evaporated to its gaseous form.

## **2.2.3 Bisphenol A plant**

Another raw material required for the synthesis of polycarbonate is bisphenol A (BPA), produced in the BPA plant. Figure 8 shows the flowchart of BPA production and Table 5 lists the total energy requirements per carrier.

**Table 5: Energy requirements for the production of 1 tonne of BPA.**

Energy carrier	Input (GJ/tonne)	Source
Steam	4.5 – 5.5	Calculated
Electricity	0.45 – 0.55	(SABIC IP BoZ, 2020a)
Heat loss	1.1 – 1.2	Calculated



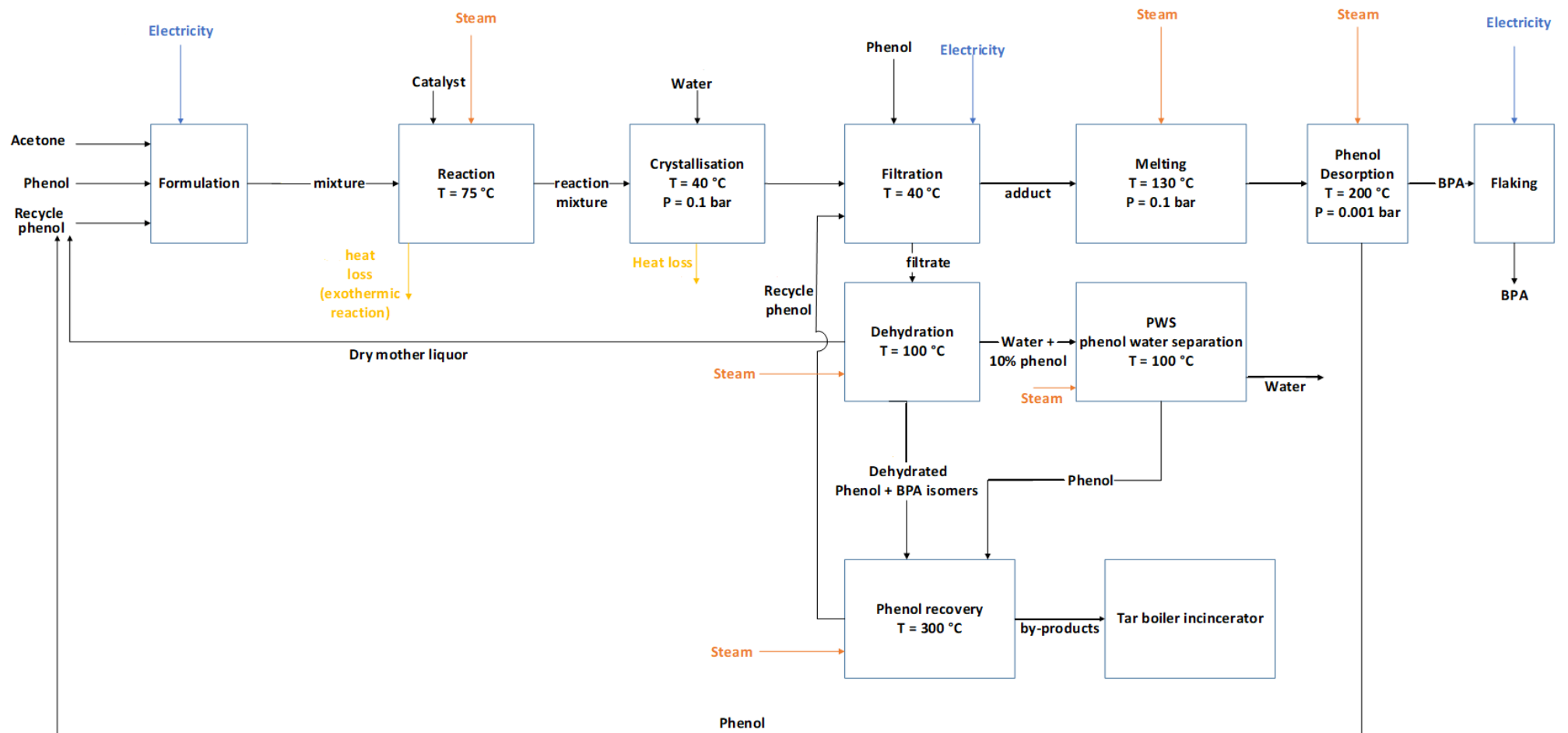

**Figure 8: Mass and energy flow chart for the production of BPA. For confidential reasons, the mass and energy numbers are not presented in this flow chart.**

### Formulation

In the formulation step acetone and fresh as well as recycled phenol are mixed in the required proportions to facilitate the BPA forming reaction. SABIC IP BoZ imports the raw materials acetone and phenol.

### Reaction

BPA is produced by a condensation reaction of acetone with phenol. The reaction is catalysed by a strong acid such as hydrogen chloride (HCl), sulfuric acid (H<sub>2</sub>SO<sub>4</sub>) or sulfonated polystyrene resin (PlasticsEurope, 2019a). Figure 9 shows the reaction equation. The reaction is slightly exothermic. Though the reaction only requires 2 moles of phenol for every mole of acetone, a large excess of phenol (6:1 to 15:1) is used in industry to achieve full condensation (PlasticsEurope, 2019a). In the material and energy flow analysis an excess phenol to acetone of 10:1 is assumed. The reaction is performed in a fixed bed reactor over which the reaction mixture is passed (Ullman, 2007).

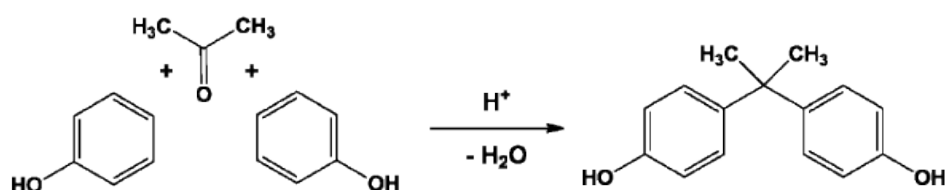

**Figure 9: BPA synthesis from acetone and phenol** (Vautherin & Lopes Cardoso, 2019).

### Crystallisation

The product of the reaction is a phenol solution of BPA, by-products such as BPA isomers, the water formed by the reaction and unreacted acetone. As the purity of the BPA influences the colour of the polycarbonate, it is important that the BPA is of high purity. Hence, the following steps are aimed to isolate and purify the BPA. The reaction mixture is cooled to 40 °C by the addition of 2-20 wt% water (11 wt% assumed in calculations), leading to the crystallization of the 1:1 BPA-phenol adduct (Neagu, 1998; Brunelle & Korn, 2005).

### Filtration

The solid BPA-adduct is isolated by filtration. The solid cake is washed with fresh and recycled phenol (Czub, n.d.). The filtrate is treated to remove by-products and recover phenol.

### Dehydration

The filtrate continues to the dehydration step. Water is removed and part of the dewatered mother liquor containing phenol and some by-products (isomers) is recycled back into the formulation step to be reused in the reactor where the isomers revert to the desired BPA. The removed water with some dissolved phenol passes to the phenol water separation step in which further phenol is recovered by distillation under low pressure. The water is further treated in the biological wastewater treatment plant. The remaining part of the dewatered phenol solution that contains the isomers of BPA continues to phenol recovery.

### Phenol recovery

In the phenol recovery step, phenol is recovered by cracking of the solution of phenol and BPA by-products obtained in the dehydration step. The by-products are incinerated in the TAR boiler to generate steam.

### Melting

The cake that remains after the filtration step contains the BPA-phenol adduct. To break the adduct, heat is applied in the melting step. Melting proceeds at temperatures of 130 °C and pressures between 0.01 and 0.1 bar (Brunelle & Korn, 2005; Neagu, 1998).

### Phenol desorption

The BPA is steam stripped from phenol in a desorption column at 200 °C at near vacuum (0.001 bar) (Neagu, 1998). The desorbed phenol is recycled to the filtration step.

### Flaking

Lastly, the BPA is cooled and mechanically flaked.

## 2.2.4 Resin plant

In the resin plant the previously produced phosgene and BPA are reacted to form polycarbonate. The synthesis of polycarbonate at SABIC IP BoZ is a continuous process (Mehta, 2020). Figure 11 shows a flow chart for the production of polycarbonate powder, Table 6 lists the energy requirements per carrier.

**Table 6: Energy requirements for the production of 1 tonne of polycarbonate powder.**

Energy carrier	Input (GJ/tonne)	Source
Steam	5.45 – 6.65	(SABIC IP BoZ, 2020a)
Electricity	0.33 – 0.40	Calculated based on (SABIC IP BoZ, 2020a)
Heat loss	1.25 – 1.40	Calculated

At SABIC IP BoZ the interfacial polycondensation process is used. In this process BPA and phosgene are reacted at 20–40 °C in a two-phase system consisting of an aqueous, alkaline phase and an immiscible organic phase (PlasticsEurope, 2019b). As suggested by the name, the reaction occurs at the interface between the two phases (Ullman, 2016). Essentially, the reaction is a step-growth polymerization in which chlorine ions are eliminated. Figure 10 shows the reaction equation.

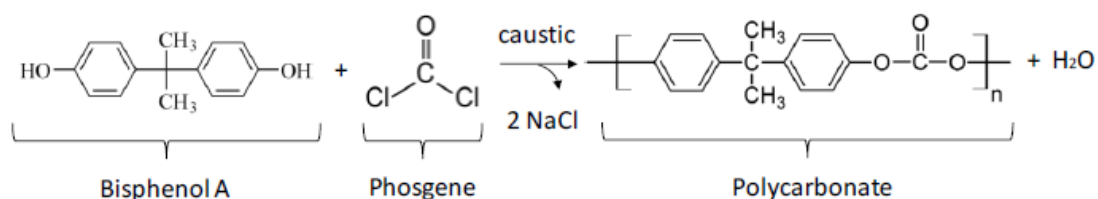

**Figure 10: Polycarbonate synthesis from BPA and phosgene (PlasticsEurope, 2019b).**

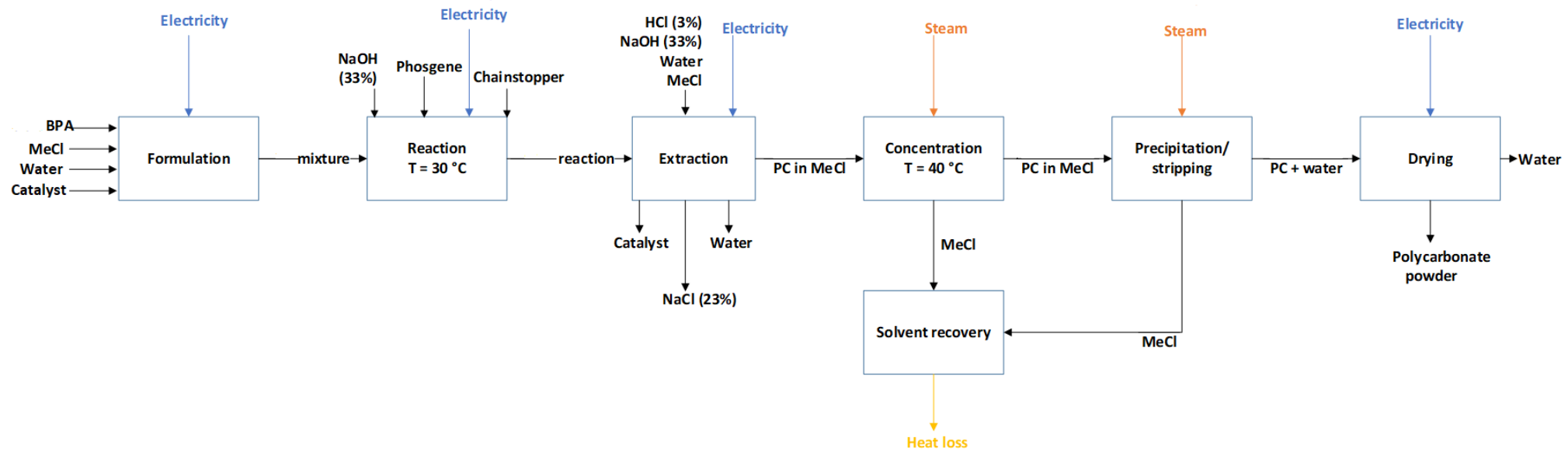

**Figure 11: Mass and energy flow chart for the production of polycarbonate powder. For confidential reasons, the mass and energy numbers are not presented in this flow chart.**

### **Formulation**

In the first step, the required amounts of BPA, dichloromethane and water are mixed. Dichloromethane and water are mixed in a ratio of 5:1 (SABIC IP BoZ, 2020a). The catalyst, often a tertiary aliphatic amine, is added in a small amount (0.1-3 wt%) (Mark, 2004).

### **Reaction**

In the reaction step, the BPA and NaOH form the BPA sodium salt (equation 3). NaOH also serves to maintain the reaction pH of 10-12. The BPA sodium salt is reacted with the phosgene at the interface of the two phases to produce polycarbonate and NaCl (equation 4). To complete the reaction 15 mol% excess phosgene is used. Unused phosgene hydrolyses to form sodium carbonate (Mark, 2004).

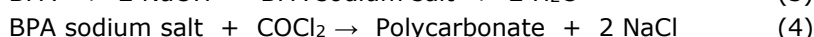
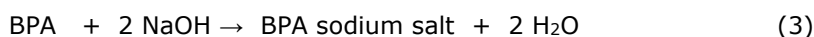

The polycarbonate dissolves into the organic phase (dichloromethane), the NaCl is concentrated in the aqueous phase. With 4 different phases present in the reactor; solid BPA, gaseous phosgene; the organic dichloromethane phase and the aqueous phase, efficient mixing is important to ensure contact between all phases for the reaction to occur (Mark, 2004). To control the length of the polymer chain, monofunctional phenol chain stoppers are added to form the terminal groups of the polycarbonate (Ullman, 2016). After the polycondensation has been terminated by the addition of the chain stoppers, the formed polycarbonate is extracted (Van Luijk, 2003).

### **Extraction**

By step-wise centrifugation the aqueous phase containing NaCl is separated from the organic phase. The NaCl solution (brine) is recovered for reuse in the chlorine plant. During brine recovery the brine is steam-stripped of dichloromethane after which solid particles and impurities are removed using filtration and activated carbon. The concentration of the brine is increased from 22-23 wt% to a final concentration of 26 wt% by adding fresh NaCl to the brine (Eijsbouts, 2008; SABIC IP BoZ, Online Communication, 2020a). The organic dichloromethane phase is washed with dilute hydrochloric acid to neutralise the solution and electrolytes are removed by washing with demineralised water (Ullman, 2016).

### **Concentration**

The polymer containing solution is then concentrated by heating in heat exchangers. Dichloromethane evaporating from the thickening polymer solution is recovered for reuse. A cyclone is used to separate the solvent vapours from the polymer solution (Van Luijk, 2003).

### **Precipitation/stripping**

Following concentration, the polymer is precipitated from the dichloromethane in two precipitation steps. First, the solution is passed through a heat exchanger. Second, remaining solvent is removed using steam precipitation jets (Van Luijk, 2003). The polycarbonate solution is atomised and sprayed into a steam atmosphere of sufficient pressure (7-15 bar) and temperature (150 – 260 °C) to evaporate dichloromethane from the droplets. For the mass and energy flow analysis steam of 240 °C and 18 barg was assumed. The steam partially condenses on the polycarbonate resulting in a wet powder (25-60 wt%) (United States Patent No. US 6362304, 2002). Steam precipitation is a highly energy intensive process that requires large amounts of steam (Mehta, 2020).

### **Drying**

The water is removed from the polycarbonate drying using multiple drying steps including column drying, spiral drying and separation in a cyclone (Van Luijk, 2003). Finally, a dry

polycarbonate powder (water content <1 wt%) is obtained. Part of this polycarbonate powder is sold directly under the name PC Resin and another part is processed further to Lexan in the compounding/extrusion plants.

## 2.3 Compounding/extrusion plants

The polymer powders are shaped into their final form in the compounding and extrusion plants. At these plants the powders are melted and mixed with other polymers to create the polymer blends and additives and pigments are added to tune the final properties. Next, the polymer mixture is moulded to its final form. The Lexan Finishing, Noryl and Flexible Compounding plant produce plastic pellets, whereas the Specialty Film & Sheet plant produces thin sheets and films. Chemical reactions do not occur in the compounding/extrusion plants.

The production of the various resins (Lexan in LXF plant, Noryl in Noryl plant and Cycology, Xenoy and Valox in FCP plant) essentially follows the same process. Losses occurring during the extrusion process are assumed to be negligible so 1 tonne of polymer powder is extruded to 1 tonne of resin. The electricity requirements depend on the type of polymer to be extruded.

The process occurring in the compounding plants exists of two main steps; mixing and extrusion.

### **Mixing**

The polymer powder produced in the manufacturing plants is transported to the corresponding compounding/extrusion plant. Additives such as heat or UV stabilisers, colour pigments, flame retardants, fillers, lubricants and reinforcements are not produced in Bergen op Zoom and thus imported to the site. First, the polymer powders are blended with additives to produce the desired grade of material. Next, the material is dried to prevent polymer degradation. For both polycarbonate and Noryl moisture leads to lower molecular weight polymers leading to poorer performance (Wagner Jr., Mount III, & Giles Jr., 2014). After drying, the polymer material is fed to the extruder.

### **Extrusion**

In the extruder, the material is melted by dissipation in the extruder screws to a liquid substance. SABIC IP BoZ uses double screw extruders to convey, heat, melt and mix the plastics. Melting of the polymer powders is achieved by the mechanical energy of the rotating screws. Additionally, hot plates are used to further increase the temperature. Extruders mostly require electricity for their operation. The liquid is pushed through a mould, the die, resulting in long plastic strands (Figure 12). The strands are cooled in water to solidify. In the pelletiser, the strands are chopped into pellets by a rotating blade (Ullman, 2016). Optionally the pellets are further treated with secondary operations to enhance certain properties (Wagner Jr., Mount III, & Giles Jr., 2014). Lastly, the pellets are inspected and stored.

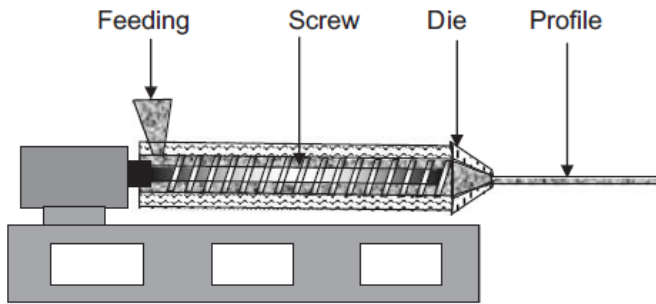

**Figure 12: Extrusion principle** (Biron, 2013).

According to SABIC IP BoZ the electricity requirements to heat and provide pressure to extrude 1 tonne of resin for various polymers is between 1.0 and 3.0 GJ/tonne (SABIC IP BoZ, Online Communication, 2020a). Besides for heat and pressure, electricity is also required to drive the motor system and for cooling. Both the motor drive and cooling require around 0.25 kWh of electricity per kg of polymer, or 0.9 GJ/tonne (euRECIPE, 2006). For our calculations, we assumed the energy use for extrusion to be 2.0 GJ/tonne. The European benchmarking survey estimates the electricity use of extrusion around 0.63 kWh/kg or 2.27 GJ/tonne (euRECIPE, 2006).

### 2.3.1 Lexan Finishing plant

In the Lexan Finishing plant, the polycarbonate powder is shaped to the final product, Lexan resin. The production of Lexan resin is a batch process (Mehta, 2020). As Lexan is often used for optical applications, drying is an important step to achieve highly transparent resins. For optical applications, the moisture content must be less than 0.1 wt% (0.2 wt% for other applications). Depending on the grade of Lexan resin to be produced, optimum melt temperatures in the extruder vary from 280-320 °C (Ullman, 2016).

### 2.3.2 Specialty Film & Sheet plant

In the specialty film and sheet plant (SF&S), Lexan sheets and films are produced. The SF&S plant has six production lines; line 1 and 2 produce solid sheets, line 3 produces solid sheets and films, line 4 produces solid sheets with optical quality and line 5 and 6 produce films (Mota, 2018). Dry polycarbonate powder enters the plant, where it is first mixed with additives such as plasticisers and heat stabilisers. The polycarbonate mixture is then dried to prevent polymer degradation. The dry mixture is fed to an extruder where it is melted. The optimum temperature at the die for polycarbonate sheets or films is between 249-266 °C (Mota, 2018). The output of the extruder is a sheet that is pulled away from the extruder at constant velocity. The sheet is rolled to the desired thickness by calendaring. In the calendaring process, the sheet is pressed between internally heated counter rotating rolls (Mota, 2018). Calendar machines can contain up to seven rolls (Ullman, 2016). When the final thickness has been achieved, the sheet is cooled to solidify. Optionally, secondary operations such as masking, flame treatment and cutting are performed. Lastly, the product is inspected and stored.

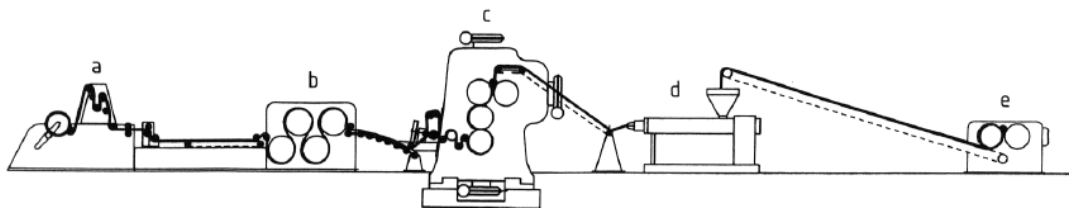

**Figure 13: Calendaring line; a) Cutter; b) Cooling rolls; c) Four-roll calender; d) Extruder; e) Mixing roll mill** (Ullman, 2016).

### 2.3.3 Flexible Compounding plant

In the flexible compounding plant various polymer blends are produced such as Valox, Xenoy and Cycloy. The FCP plant makes hundreds of different products, both make-to-order and make-to-stock. Production is divided into 10 production groups and 8 production lines, each dedicated to a number of product groups (Klompenhouwer, Lukszo, & Janssen, 2007).

## 2.4 Material and Energy Flow Analysis

The CHP at SABIC IP BoZ produces around 80 tonnes of steam per hour on average. Since the steam is generated on average at 240 °C and 18 barg, the steam has an energy-content of 2732 kJ/kg. Thus, the CHP generates 1.91 PJ of steam per year. Adding the steam generation in the hydrogen boiler, TAR boiler and the steam purchased from Air Liquide, the total steam use at the site is around 2.87 PJ/yr. The CHP also produces 0.96 PJ electricity per year and 0.56 PJ of electricity is imported annually (SABIC IP BoZ, 2020e). The total energy supply (heat + electricity) at the site adds up to 4.4 PJ/yr.

The mass and energy balances per production plant have been normalised to the production of 1 tonne of end-product for every plant. SABIC IP BoZ has an average yearly production of 239 kilotonnes (kt) of polycarbonate powder of which about 123 kt is further processed to Lexan. Table 8 lists the energy requirements for every plant involved in the polycarbonate production process to produce 1 tonne of Lexan.

**Table 7: Energy requirements for the production of 1 tonne of Lexan.**

Process	Energy carrier	Energy input (GJ/tonne)
Resin plant - 1 t PC powder	Steam	6.00
	Electricity	0.37
	Heat loss	1.38
BPA plant - 0.9 t BPA	Steam	4.49
	Electricity	0.45
	Heat loss	1.02
Phosgene plant - 0.45 t phosgene	Steam	0.18
	Electricity	0.03
	Heat loss	0.13
Chlorine - 0.33 t Cl <sub>2</sub>	Steam	0.33
	Electricity	3.45
	Heat loss	0.35
Compounding - 1 t PC	Electricity	2.00
<b>TOTAL</b>	<b>Steam</b>	<b>11.00</b>
	<b>Electricity</b>	<b>6.30</b>
	<b>Heat loss</b>	<b>2.87</b>

The total energy requirements for the production of 1 tonne of polycarbonate *powder* adds up to 15.3 GJ (total steam usage of 11.0 GJ plus the total electricity use for 1 tonne PC powder of 4.3 GJ and excluding extrusion) and the total energy needed to produce 1 tonne of Lexan adds up to around 17.3 GJ/tonne (thus, including extrusion). For the production of 239 kt of polycarbonate *powder*, the energy requirements would add up to 3.7 PJ. Assuming



123 kt of the polycarbonate powder is compounded to Lexan, this would require a total of 0.25 PJ of electricity. To produce 123 kt Noryl and FCP product, 0.28 PJ of electricity is required. Since the total energy supply (heat + electricity) at the site adds up to 4.4 PJ/yr, this leaves approximately 0.21 PJ of steam. To explain the difference it is likely that the steam use of production processes has been underestimated. Additionally, a small amount of steam that could not be quantified is also used in the compounding plants and steam is used to heat the on-site buildings.

Using the NEa (2020) data and assuming a CHP electrical efficiency of 28% and thermal efficiency of 55% (total CHP efficiency of 83%), the emission factors for heat and electricity generation by the cogenerator were determined at 48.41 kgCO<sub>2</sub>/GJ for heat and 0.38 kgCO<sub>2</sub>/kWh for electricity. The steam imported from Air Liquide is regarded as a waste product of which the emissions are allocated to Air Liquide. For the hydrogen combustion boiler zero emissions were assumed. The emission factor of the TAR boiler was also assumed to be zero, as the burning of tar does not qualify as a CO<sub>2</sub> emitting installation under the NEa criteria. Based on the fractions of on-site produced steam and electricity and imported steam and electricity, the total scope 1 and 2 emissions for the production of 116 kt of PC powder, 123 kt of Lexan and 123 kt of compounding product were determined at 264 kt CO<sub>2</sub> in 2018.

# 3 Products and application

Table 9 lists the main products produced at SABIC IP BoZ and their applications. The polycarbonate powder production was estimated to be 239 kt in 2018. For the blended polymer products produced in the FCP and Noryl plant only the total production number could be calculated.

**Table 8: SABIC IP BoZ main products and applications.**

Brand name	Chemical name	Application	Production volume 2018 (kt)
<b>PC resin</b>	Polycarbonate (PC)	High impact/light weight/stiff transparent applications (i.e. glass replacement, electrical hardware, water tank bottles etc.) & aesthetics enhancement	116
<b>Lexan</b>			123
<b>Noryl</b>	Polyphenylene oxide (PPO)/ Polystyrene (PS)	Electrical hardware, automotive (dashboard)	123
<b>Cycoloy</b>	Polycarbonate (PC)/ Acrylonitrile-butadiene-styrene (ABS)	Ski boots, medical devices and pharmaceutical applications	
<b>Xenoy</b>	Polycarbonate (PC)/Polybutylene terephthalate (PBT)	Automotive exterior (bumper), hospital beds	
<b>Valox</b>	Polyethylene terephthalate (PET)/ Polybutylene terephthalate (PBT)/ Polycarbonate (PC)	Electronics, appliance handles and housings, sprinklers	

## 3.1 Lexan polycarbonate

SABIC is one of the world leading producers of polycarbonate, which it sells in a pure powder form (PC Resin) and in compounded form under the name Lexan (IHS Markit, 2018). The polymer was independently created by both Bayer and GE Plastics in their attempts to make a polymer superior to polyethylene terephthalate (PET). Lexan polycarbonate was first introduced to the US market in 1960 by General Electric (Ullman, 2016). Lexan has unique properties including extreme rigidity, transparency and heat resistance. Furthermore, it can be blended with other polymers to synthesise a variety of materials with different properties and can be recycled (Coe, 2000). Lexan is often used as a replacement of glass, for instance in greenhouses, in the automotive industry for headlight covers and in building and construction for window panes and roofing (SABIC Innovative Plastics, 2011; Ullman, Ullmann's Polymers and Plastics: Products and Processes, 2016). SABIC IP BoZ produces Lexan resins, sheets and films in different grades suitable for different applications.

### 3.1.1 Applications

The polycarbonate consumption is dominated by four main sectors; Building and Construction, Electrical & Electronics industries, Optical Media and Automotive. In these sectors polycarbonate is used in unique applications meaning that it cannot be replaced by another material if the same material performance is desired. Polycarbonate is an enabling technology for innovation due to its many unique properties (PlasticsEurope, n.d.).

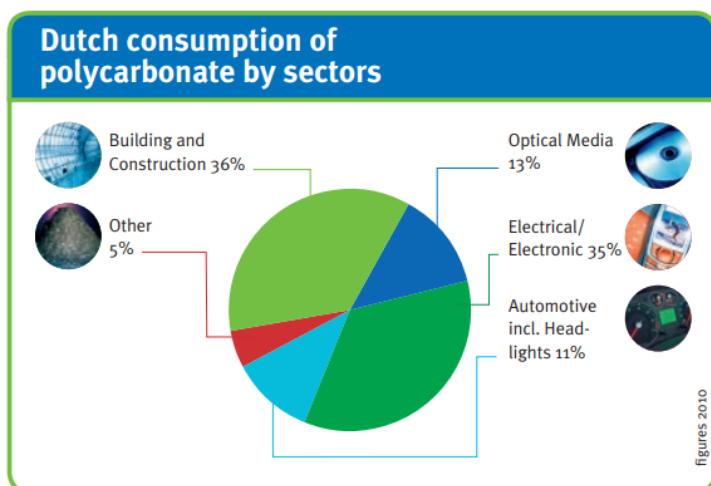
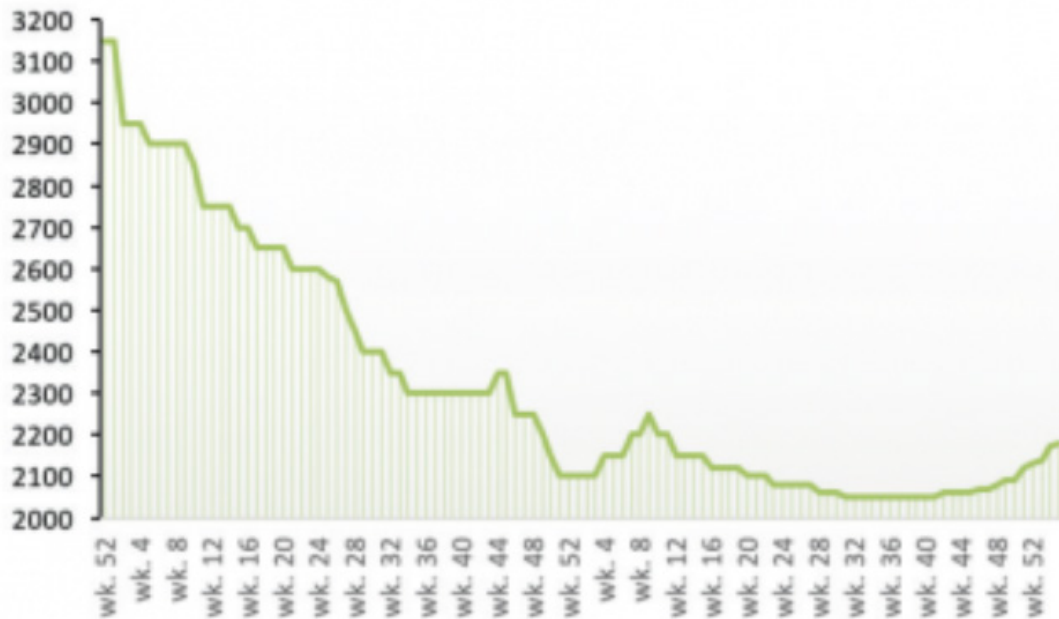

**Figure 14: Dutch polycarbonate consumption by sector** (PlasticsEurope, n.d.).

### 3.1.2 Value added & market price

The Netherlands produces about 20% of the total European polycarbonate production, generating about 490 million euro of value added. Most of the polycarbonate is produced for export and is supplied to consumers all over the world. Over 21,000 jobs in the Netherlands are related to the production and consumption of polycarbonate (PlasticsEurope, n.d.).

The largest companies in the polycarbonate market are Bayer and SABIC, that each hold 27% of the world market (Mota, 2018). The price of polycarbonate is greatly determined by the oil price and the demand for polycarbonate products. Due to the COVID-19 crisis, both oil prices and the demand for plastics fell in 2020 as many final product processing plants were closed (i.e. car manufacturing facilities), resulting in a drop in the market price of plastics (Van Lockhuyzen, 2020). However, the COVID-19 crisis also led to an increased demand for polycarbonate sheets used for protection. In reaction to the crisis, SABIC IP BoZ has increased the production of Lexan sheets (Peeters, 2020). Figure 15 shows the development of the average price of clear polycarbonate of the last two years in euros per tonne.



**Figure 15: Price development of clear polycarbonate in 2019 and 2020 (€/tonne)**  
*(Kunststof & Rubber, 2021).*

### 3.2 Other engineering thermoplastics

The thermoplastics produced in the Flexible Compounding Plant are made to the order of customers. The amount of additives and polymer in a blend are weighted by hand and can therefore be flexibly adapted to a customer's specific needs (SABIC IP BoZ, Personal communication, 2020e). Blends produced at SABIC IP BoZ include Cycoloy, Xenoy and Valox. The polymer blends are available in a number of different grades for specific purposes. Cycoloy is widely used in ski boots as the addition of ABS to PC improves the rigidity and low temperature toughness of the material (Ullman, Ullmann's Polymers and Plastics: Products and Processes, 2016). Xenoy and Valox resins can be made from post-consumer recycled PBT waste, lowering the energy use and environmental impact of the production process (SABIC Innovative Plastics, 2008).

# 4 Options for decarbonisation

In this chapter decarbonisation options for SABIC IP BoZ will be discussed. The decarbonisation options are categorised in 7 categories as shown below in Figure 16.

## CO<sub>2</sub> reduction categories

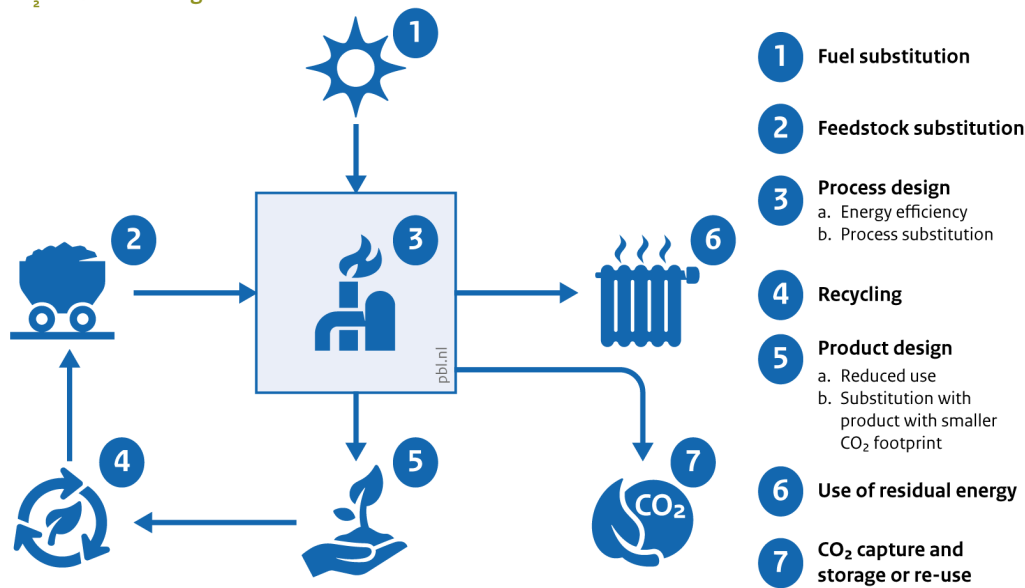

Bron: PBL

**Figure 16: CO<sub>2</sub> reduction categories.**

## 4.1 Fuel substitution

The decarbonisation options discussed in this section aim to decarbonise SABIC IP BoZ's 132 MWth gas turbine combined heat and power plant for the cogeneration of steam and electricity (European Environment Agency, 2019).

### 4.1.1 Electrification

An important industrial transition path is the so-called power-to-heat transition or electrification. In this pathway, renewable electricity is used to generate the steam that is required for industrial processes. In the chemical industry, two fully developed, commercially available power-to-heat technologies are used; the resistance element boiler and the electrode boiler (Marsidi, 2019a). Both make use of the conductive and resistive properties of water to carry electric current, have high efficiencies, can be operated flexibly to make use of low electricity prices and can be applied in CHP-hybrid concepts as boiler alternatives (Berenschot, Energy Matters, CE Delft, & Industrial Energy Experts, 2017).

In resistance element boilers, heat is generated with electricity that runs through a resistance element. Water runs over this heating element causing it to heat up to its boiling point and become steam. Resistance element boilers are also capable of heating air and

other gasses to about 600 °C, however the capacity is quite low (max 5 MWe) (Marsidi, 2019a). In electrode boilers, water flows between electrodes that are connected to a medium voltage. The electricity that is flowing through the electrodes generates an electric field that causes the water molecules to move at high speed. In this way the water heats up and vaporises into steam. Electrode boilers can produce steam up to 350 °C at 70 bar. The capacity of an electrode boiler is between 3 and 70 MWe (Marsidi, 2019a). As estimations are that SABIC would require a capacity around 70 MWe, electrode boilers are more suitable for steam production at SABIC IP BoZ. The characteristics of an electrode boiler are listed in Table 10.

Switching from natural gas to electricity only will significantly increase SABIC IP BoZ's electricity consumption. Electrification can only be regarded as a decarbonisation option if the electricity used is generated from renewable resources such as wind and solar power. Hence, one of the key priorities in the Delta region<sup>1</sup> is facilitating direct access to hundreds of megawatts of wind energy for industry (CE Delft, 2018). When there is a direct connection with SABIC IP BoZ, a challenge regarding the use of renewable electricity is the intermittency of the supply as both wind and solar energy are non-continuous sources.

The price of electricity is highly uncertain and dependent on fuel and carbon dioxide prices. In the Netherlands, coal fired power plants are being closed and the share of renewable electricity is increasing. It is expected that by 2030, 75% of the total electricity generated will be from renewable resources such as solar and wind (PBL, 2020). The price of green electricity is projected to be 57 €/MWh in 2030 (PBL, 2019).

**Table 9: Characteristics of electrode boilers.**

Characteristics	Value	Reference
<b>Fuel input</b>	Electricity	
<b>Energy output</b>	Steam (up to 350 °C and 70 bar)	(Berenschot, Energy Matters, CE Delft, & Industrial Energy Experts, 2017)
<b>Emissions</b>	0	
<b>Input capacity</b>	20 MW <sub>e</sub>	(Marsidi & Lensink, 2020)
<b>Output capacity</b>	19.8 MW <sub>th</sub>	(Marsidi & Lensink, 2020)
<b>Efficiency</b>	99%	(Marsidi & Lensink, 2020)
<b>Full load hours</b>	2000 h/yr*	(Marsidi & Lensink, 2020)
<b>TRL</b>	9	(Berenschot, Energy Matters, CE Delft, & Industrial Energy Experts, 2017)
<b>Lifetime</b>	15 yr	(Marsidi & Lensink, 2020)
<b>Investment cost</b>	115 €/kW <sub>th</sub>	(Marsidi & Lensink, 2020)
<b>Operational cost</b>	49 €/kW <sub>th</sub> /yr Fixed operational costs 0.037 €/kWh <sub>th</sub> Variable operational costs	(Marsidi & Lensink, 2020)

\* In theory full load hours could be higher. In 2030 a fully renewable electricity supply can be guaranteed for 8000 hr/yr.

<sup>1</sup> SABIC IP BoZ is located in what is called the 'Rijn-Maas-Scheldedelta', which is a river delta in the Netherlands and Belgium that is formed by the confluence of the Rhine, the Meuse and the Scheldt.

### 4.1.2 Biomass

An alternative carbon-neutral fuel that could be used to achieve decarbonisation of industry is sustainably produced biomass. Different forms of biomass can be used to generate both heat and electricity. Solid biomass such as organic waste or wood could be burned directly in biomass boilers or converted by microorganisms to biogas. The most commonly used source of biomass in the Dutch industry is wood in the form of chips or pellets. The biomass is often imported from countries like the United States, the Baltic Region, Russia, Germany and Norway (Flach & Phillips, 2019).

Three main processes exist for the conversion of biomass to fuel; direct-firing, gasification and anaerobic digestion. In a direct-fired plant biomass is burned in a stoker or fluidised bed boiler to produce high pressure steam. Direct-fired systems accept a wide range of biomass feedstock types; however, wood pellets and chips are most commonly used. As SABIC IP BoZ does not produce a solid biomass waste stream, it would have to import biomass to the site. Since 2013 Eneco operates a direct-fired biomass plant for the generation of heat and electricity in Farmsum. The plant has a similar capacity as the CHP at SABIC IP BoZ (Eneco 135 MWth, SABIC IP BoZ 132 MWth) and consumes 300,000 million tonnes of waste wood and chips per year (Flach & Phillips, 2019). Table 11 lists the characteristics of a direct-fired biomass boiler.

**Table 10: Characteristics of direct-fired biomass boilers** (Cremers, Strengers, Beurskens, & Lensink, 2020).

Characteristics	Value
<b>Fuel input</b>	Wood pellets
<b>Energy content of fuel</b>	17 GJ/tonne
<b>Fuel price</b>	180 €/tonne
<b>Energy output</b>	Steam
<b>Emissions</b>	0*
<b>Capacity</b>	20 MWth
<b>Full load hours</b>	8500 h/yr
<b>Efficiency</b>	90%
<b>Lifetime</b>	12 years
<b>TRL</b>	9
<b>Investment cost</b>	605 €/kW <sub>th</sub>
<b>Operational cost</b>	46 €/kW <sub>th</sub> /yr Fixed operational costs 0.004 €/kWh Variable operational costs

\* Emissions from the burning of biomass are allocated to the point where the biomass is produced and harvested. Hence, the emissions from the use of biomass by SABIC IP BoZ are zero.

In a gasification system, solid biomass (wood chips/pellets) is heated in an oxygen-deprived environment to produce syngas (CO and H<sub>2</sub>). The syngas is then cleaned and burned in gas turbines to produce heat and electricity. In CHP concepts, gasification systems can reach higher efficiencies than direct-fired installations as the syngas is more efficiently converted to electricity (BlueTerra, 2018). For a gas turbine CHP to run on syngas instead of natural gas, minor adaptations to the burner system need to be made. Due to a lacking infrastructure syngas cannot be purchased and has to be produced on-site (Wolbers, 2020). Table 12 lists the characteristics of a biomass gasification installation.

**Table 11: Characteristics of a biomass gasification installation** (Cremers, Strengers, Beurskens, & Lensink, 2020).

Characteristics	Value
<b>Fuel input</b>	Wood pellets
<b>Energy content of fuel</b>	17 GJ/tonne
<b>Fuel price</b>	180 €/tonne
<b>Energy output</b>	Syngas
<b>Emissions</b>	0*
<b>Capacity</b>	32 MW input
<b>Full load hours</b>	7500 h/yr
<b>Efficiency</b>	65%
<b>Lifetime</b>	12 years
<b>TRL</b>	9
<b>Investment cost</b>	2250 €/kW output
<b>Operational cost</b>	135 €/kW output

\* Emissions from the burning of biomass are allocated to the point where the biomass is produced and harvested. Hence, the emissions from the use of biomass by SABIC IP BoZ are zero.

In anaerobic digestion wet biomass is converted to biogas by microorganisms. The biogas (CH<sub>4</sub> + CO<sub>2</sub>) can then be burned to generate steam and electricity. Anaerobic digestion requires the presence of a wet biomass source. SABIC IP BoZ has a biological wastewater treatment plant of which the sludge could provide a source of wet biomass to be used for energy generation. However, the supply of sludge is insufficient to meet the site's energy requirements, so additional biomass will have to be imported, potentially from neighbour Cargill. The limited availability of biogas and a lacking infrastructure make it necessary to produce the biogas on-site (Wolbers, 2020). Table 13 lists the cost of an anaerobic digestion installation and a digester with a new CHP.

**Table 12: Characteristics of biomass digestion** (Boots, Wolbers, & Lensink, 2020).

Characteristics	Digester	Digester + CHP
<b>Fuel input</b>	Wet biomass	Wet biomass
<b>Fuel price (dec-19)</b>	27.8 €/tonne	27.8 €/tonne
<b>Energy content</b>	3.4 GJ biogas/tonne	3.4 GJ biogas/tonne
<b>Energy output</b>	Biogas	Heat and electricity
<b>Emissions</b>	0*	0*
<b>Input Capacity</b>	5.5 MW <sub>th</sub>	5.5 MW <sub>th</sub>
<b>Electric capacity</b>		2.3 MW <sub>e</sub>
<b>Thermal output capacity</b>		2.6 MW <sub>th</sub>
<b>Full load hours electricity</b>	8000 h/yr	8000 h/yr
<b>Full load hours heat</b>		7300 h/yr
<b>Efficiency</b>	62%	41%
<b>Lifetime</b>	12 years	12 years
<b>TRL</b>	9	9
<b>Investment cost</b>	808 €/kW input (digester) 404 €/kW output (gas cleaning)	898 €/kW <sub>th</sub> input
<b>Operational cost</b>	111 €/kW input (digester) Fixed operational costs	81 €/kW <sub>th</sub> input Fixed operational costs

\* Emissions from the burning of biomass are allocated to the point where the biomass is produced and harvested. Hence, the emissions from the use of biomass by SABIC IP BoZ are zero.



### 4.1.3 Hydrogen

Another promising energy carrier that could substitute natural gas, is hydrogen. For hydrogen to be regarded a decarbonisation alternative however, it should be produced from renewable resources. Hydrogen is categorised to three categories based on its production route; grey, blue and green hydrogen. Grey hydrogen involves the production of hydrogen from fossil-fuels with CO<sub>2</sub> emissions resulting from the production process. Most of the hydrogen currently on the market is grey hydrogen produced by steam methane reforming (SMR). Blue hydrogen is also produced from fossil fuels, however the CO<sub>2</sub> emissions during production are captured using carbon capture and storage technology (see 4.7 for more detail). Lastly, green hydrogen is produced using renewable resources. Currently, the most employed technology for the production of green hydrogen is electrolysis of water using green electricity. The economic feasibility of using hydrogen depends largely on its production route, the available infrastructure for hydrogen and the price of hydrogen which currently is higher than the price of natural gas (de Bruyn, Jongsma, Kampman, Gorlach, & Thie, 2020).

#### Hydrogen combustion

Hydrogen can be implemented with minimal modifications to the existing processes. Table 14 shows the costs for installing a new hydrogen boiler. Hydrogen boilers are a commercially available technology (Technological Readiness Level [TRL] 9) (Element Energy, Advisian, & Cardiff University, 2019).

**Table 13: Characteristics of a hydrogen boiler** (E4tech, UCL Energy Institute, & Kiwa, 2015).

Characteristics	Value
<b>Fuel input</b>	Hydrogen
<b>Energy output</b>	Steam
<b>Emissions</b>	Water vapour, NO <sub>x</sub>
<b>Capacity</b>	5 – 200 MW
<b>Efficiency</b>	90%
<b>Lifetime</b>	25 years
<b>TRL</b>	9
<b>Investment cost</b>	98.3 GBP/kW (121.11 €/kW)*
<b>Operational cost</b>	3.2 GBP/kWh/yr (3.94 €/kWh/yr) Fixed operational costs*

\* Conversion from GBP2015 to EUR2020. GBP2015 to GBP2020 11.59% inflation<sup>2</sup>. 1 GBP2020 = 1.104 EUR2020<sup>3</sup>.

Hydrogen can also be used as a fuel in a conventional gas-turbine CHP installations to generate steam and electricity. Though the technology has an estimated TRL of 7-9 its application to large scale industry is limited (SBC Energy Institute, 2014). The 16 MW Fusina plant in Italy is the first industrial-scale application featuring a hydrogen fuelled gas turbine and heat recovery steam generator (Power Engineering International, 2010). Table 15 shows the costs of installing a new hydrogen-fuelled CHP plant. To save money and maximise the lifespan of existing installations, research into retrofitting natural gas CHPs to hydrogen or flexibly fuelled CHPs is ongoing. In Hamburg a natural gas CHP is being converted to hydrogen and the Dutch Topsector Energie is also involved in a project regarding retrofitting CHPs to hydrogen (Ali, 2019; Topsector Energie, n.d.).

<sup>2</sup> Source: <https://www.in2013dollars.com/uk/inflation/2015>

<sup>3</sup> Exchange rate on December 8<sup>th</sup> 2020: <https://nl.exchangerates.org.uk/historische/GBP-EUR.html>

**Table 14: Characteristics of a hydrogen CHP.**

Characteristics	Value	Reference
<b>Fuel input</b>	Hydrogen	
<b>Energy output</b>	Steam, electricity	
<b>Emissions</b>	Water vapour, NO <sub>x</sub>	
<b>Capacity</b>	1 – 300 MW <sub>e</sub>	(SBC Energy Institute, 2014)
<b>Electrical efficiency (HHV)</b>	< 45% open cycle < 60% combined cycle	(SBC Energy Institute, 2014)
<b>Lifetime</b>	20 years	(E4tech, UCL Energy Institute, & Kiwa, 2015); (SBC Energy Institute, 2014)
<b>TRL</b>	7-9	(SBC Energy Institute, 2014)
<b>Investment cost</b>	389 - 555 GBP/kW (480 – 685 €/kW)*	(E4tech, UCL Energy Institute, & Kiwa, 2015);
<b>Operational cost</b>	0.003 - 0.0043 GBP/kW/yr (0.004 – 0.005 €/kW/yr)*	(E4tech, UCL Energy Institute, & Kiwa, 2015);

\* Conversion from GBP2015 to EUR2020. GBP2015 to GBP2020 11.59% inflation<sup>2</sup>. 1 GBP2020 = 1.104 EUR2020<sup>3</sup>.

The best technology for hydrogen combustion for SABIC IP BoZ is probably the installation of new hydrogen boilers. The costs for building a new hydrogen CHP are considerable, and retrofitting existing CHPs to hydrogen is currently still under development. However, having a separate hydrogen CHP system would enable the old natural gas-fired system to be used as back-up and enable a gradual transition from natural gas to hydrogen.

### Hydrogen production

Switching from natural gas to hydrogen requires a stable supply of carbon-free hydrogen. Hence, a key priority of the Delta region is to develop a local, open infrastructure for carbon-free hydrogen connecting regional producers and users. Besides facilitating an infrastructure, the region also aims at enabling conditions for the realization of electrolysis units for the production of green hydrogen and oxygen (CE Delft, 2018). Through Air Liquide, SABIC IP BoZ is connected to the hydrogen pipeline between Pernis and Antwerp enabling a stable supply stream of hydrogen to the site.

The price of grey hydrogen is currently around 1.50 €/kg and largely determined by the price of natural gas (van Hulst, 2019). Future blue hydrogen will be priced higher than grey hydrogen, with its price being driven by the price of natural gas as well as the cost of carbon capture and storage or reuse. The price of blue hydrogen is expected to quickly come down after the deployment phase, when CCS/U is scaled up and standardised. The price of green hydrogen is currently between 3.50 – 5.00 €/kg as a result of the limited capacity for electrolysis and costs of green electricity (van Hulst, 2019). At current prices using green hydrogen is economically not viable. However, if current CO<sub>2</sub> pricing trajectories continue, the price of hydrogen derived from natural gas will increase (van Hulst, 2019). At a CO<sub>2</sub> price of 30 €/tonne blue hydrogen becomes cheaper than grey, and at a price of 60 €/tonne CO<sub>2</sub> green hydrogen becomes competitive (GasTerra, 2019). Add to this the technical developments leading to a decreasing price of electrolyzers and of renewable electricity and green hydrogen becomes a viable, sustainable alternative (van Hulst, 2019).

Alternatively, green hydrogen could be produced on-site using electrolysis (provided that the electricity used comes from a renewable source). Some hydrogen is already produced on-site as a by-product of chlorine electrolysis, however to fully power the site using hydrogen a

much larger amount is required hence electrolyzers need to be installed on-site. Several electrolysis technologies exist, however only the Alkaline Electrolysis (AEL) and Polymer Electrolyte Membrane (PEM) have a TRL of 8/9 and are commercially available. Alkaline Electrolysis (AEL) is currently the most developed technology for hydrogen production by water electrolysis. In AEL the electrodes are made of nickel or porous metal and separated by a diaphragm. To ensure good conductivity the electrolyte must have high-mobility ions, such as potassium hydroxide (KOH). Water is split with the hydrogen ions moving to the cathode and the hydroxide ions moving to the anode. The formed hydrogen and oxygen gasses are collected by gas receivers. Electrolysis takes place in cells, at temperatures between 60-70 °C, producing hydrogen at 30 bar. The cells can be stacked to form stacks. AEL installations typically consist of multiple stacks. In 2017, the costs of hydrogen produced by AEL in Denmark were estimated to be around 3.2–3.6 €/kg (Lappalainen, 2019).

Competing with AEL is the proton-exchange membrane or polymer electrolyte membrane (PEM). Though the technology has been available for 10 years, it has not yet been applied on industrial scale. Similar to AEL, PEM consists of connected cells operating at 60-70 °C, forming multiple stacks. In a PEM electrolyser, the cathode and anode are separated by a polymeric membrane with high proton conductivity. At the anode water reacts with a catalyst to produce oxygen, electrons and hydrogen protons. The hydrogen protons are transported across the membrane to the cathode where they combine to form hydrogen (Marsidi, 2019b). In 2017, the costs of hydrogen produced by PEM in Denmark were estimated to be around 4.8-5 €/kg (Lappalainen, 2019).

Table 15 shows the current characteristics of an AEL and a PEM electrolyser. The stack lifetime is projected to increase in the future, investment and O&M costs are projected to decrease (Marsidi, 2018).

**Table 15: Characteristics of AEL and PEM for hydrogen production (Marsidi, 2018; Marsidi, 2019b).**

Characteristics	AEL	PEM
<b>Fuel input</b>	Electricity, demi water	Electricity, demi water
<b>Output</b>	Hydrogen	Hydrogen
<b>Energy content H<sub>2</sub> (MJ(LHV)/kg H<sub>2</sub>)</b>	120.1	120.1
<b>Emissions (t CO<sub>2</sub>)</b>	0 if green electricity is used	0 if green electricity is used
<b>Electricity use (kWh/kg H<sub>2</sub>)</b>	52.3 - 55	53.4 - 55.6
<b>Electricity use (MJ/MJ H<sub>2</sub>)</b>	1.57 - 1.65	1.61 - 1.64
<b>Water use (kg/kg H<sub>2</sub>)</b>	14.5	14.5
<b>Operation temperature (°C)</b>	60 - 70	60 - 70
<b>Pressure H<sub>2</sub> (barg)</b>	30	5-50
<b>Availability (%)</b>	97	97
<b>Full load hours (hours/year)</b>	8497	8497
<b>Technical lifetime of total installation (years)</b>	20-40	20-30
<b>Stack lifetime (years)</b>	7	7
<b>TRL</b>	9	8
<b>Investment cost (mln €/MW H<sub>2</sub> out (LHV))</b>	0.9 - 3.3 (€ <sub>2015</sub> ) 1.0 - 3.6 (€ <sub>2020</sub> )*	1.32 - 2.36 (€ <sub>2015</sub> ) 1.43 - 2.55 (€ <sub>2020</sub> )*
<b>Stack costs</b>	30% of investment cost	40% of investment cost
<b>Fixed operational cost excluding fuel costs (mln €/MW H<sub>2</sub> out (LHV))</b>	0.13 (€ <sub>2015</sub> ) 0.14 (€ <sub>2020</sub> )*	0.07 (€ <sub>2015</sub> ) 0.08 (€ <sub>2020</sub> )*

\* Using an average inflation rate of 8.16% from December 2015 to December 2020. Source: <https://www.inflation.eu/nl/inflatiecijfers/nederland/historische-inflatie/cpi-inflatie-nederland.aspx>

#### 4.1.4 Geothermal energy

Geothermal energy is a proven technology that provides a continuous sustainable heat supply by extracting warm water or steam from the Earth. This hot water and steam can be used to heat industrial processes and to generate electricity. Although still under development, ultra-deep geothermal energy could potentially be an option for SABIC IP BoZ. With ultra-deep geothermal energy, heat is extracted at depths greater than 4000 m and has a temperature of at least 130 °C (Platform Geothermie, DAGO, Warmtenetwerk, & EBN, 2018). Heat of this temperature is sufficient to heat some of the processes occurring at SABIC IP BoZ. The capacity and costs of geothermal energy are shown in Table 17.

The opportunities for geothermal energy in the Bergen op Zoom area are currently being researched (Concept RES West-Brabant, 2020). An exploration permit for geothermal energy at depths below the “Lithostratigrafische Noordzee Groep” has been issued to Geothermie Brabant B.V. and Hydreco GeoMEC for several locations in West-Brabant including Bergen op Zoom (Ministerie van Economische Zaken en Klimaat, 2019). In a roadmap study about climate neutrality in the Delta region, (CE Delft, 2018) states that the first geothermic source supplying heat of 110 – 180 °C could be realised in the Bergen op Zoom region by 2035. By 2040 half of the heat required at SABIC IP BoZ could be supplied by geothermic energy. SABIC IP BoZ is involved in a feasibility study about the geothermic potential in the Bergen op Zoom area with Hydreco GeoMEC, Cosun and Lamb Weston (SABIC IP BoZ, 2020f). The total costs of this project are estimated between € 2–12 million (CE Delft, 2018). In the future geothermal energy might be combined with high temperature heat pumps to be able to produce high temperature heat from a geothermal source.

**Table 16: Characteristics of ultra-deep geothermal energy** (in 't Groen, Tolsma, Mijnlieff, & Smekens, 2020).

Characteristics	Value
<b>Input</b>	Geothermal energy (heat)
<b>Main output</b>	Steam
<b>Emissions</b>	0 tCO <sub>2</sub>
<b>Capacity</b>	17 MW <sub>th</sub>
<b>Full load hours</b>	7000 h/yr
<b>Electricity use</b>	5490 MWh/yr
<b>Technical lifetime</b>	15+ yr*
<b>TRL</b>	9
<b>Investment cost</b>	2509 €/kW <sub>th</sub>
<b>Operational cost</b>	107 €/kW <sub>th</sub> /yr Fixed operational costs 0.008 €/kW <sub>th</sub> Variable operational costs

\* The reported *economical* lifetime is 15 year, but the *technical* lifetime is generally longer (up to 30 years).

## 4.2 Feedstock substitution

### 4.2.1 Bio-based polycarbonate

An important decarbonisation option for the (petro)chemical industry is the replacement of fossil-based feedstocks by bio-based alternatives. Bio-based feedstocks have the potential to reduce GHG emission and disconnect plastics from fossil fuels (Bauer, Ericsson, Hasselbalch, Nielsen, & Nilsson, 2018). A LCA study conducted by SABIC revealed that up to 65% of the

cradle-to-gate emissions of polycarbonate production result from the use of fossil feedstocks (de Brouwer & Kamps, 2008). Significant CO<sub>2</sub> emissions can be avoided by replacing fossil naphtha with renewable bio-naphtha. As the bio-based phenol derived from the bio-naphtha is chemically identical to its fossil fuel-based counterparts, it functions as drop-in replacement that requires no changes to existing processing plants. According to (SABIC, 2019b), the bio-based naphtha is obtained from second generation feedstock that does not compete with food production. The price of bio-naphtha is highly dependent on the biomass feedstock used, and therefore cannot be stated with certainty. The production of bio-based polycarbonate starts in Geleen with the feeding of the cracker with bio-based feedstocks such as bio-based naphtha. The cracker products are then processed further and transported to the Bergen op Zoom site where the bio-based polycarbonate is synthesised. In 2019, the first certified bio-based polycarbonate was produced in Bergen op Zoom (SABIC, 2019b).

#### 4.2.2 CO<sub>2</sub> as feedstock

Carbon dioxide can be used as a raw material for polycarbonate synthesis; chemically fixing the greenhouse gas in a product. According to a study by (IEA, 2019) polycarbonates can contain up to 50% of carbon dioxide by weight.

The Japanese company Asahi Kasei Corp. developed a process for producing polycarbonate using CO<sub>2</sub> as raw material and without the highly toxic phosgene (Fukuoka, Tojo, Hachiya, Aminaka, & Hasegawa, 2007). The process takes three starting materials; BPA, CO<sub>2</sub> and ethylene oxide (EO) to produce polycarbonate and monoethylene glycol (MEG). Figure 17 shows a detailed scheme of the production process. The process resembles the melt transesterification process that produces polycarbonate from BPA and diphenyl carbonate (DPC). However, the DPC used in the melt process is prepared from phosgene, phenol and sodium hydroxide or from carbon monoxide, methanol and phenol, whereas the new process makes DPC from EO and CO<sub>2</sub>. Any CO<sub>2</sub> can be used in the process, but from a system integration perspective it is preferred to utilise the CO<sub>2</sub> by-product of EO production. All intermediate products are used and recycled in following and preceding reaction steps. The process is highly energy efficient due to the use of reactive distillation in the DPC production step. In reactive distillation the reaction and distillation are performed in one step, using the heat of reaction for the distillation. Besides being phosgene and dichloromethane free, another advantage of the process is the fact that polycarbonate purification and separation steps are unnecessary. The molten PC obtained can be fed to the extruder directly. The new process results in a reduction of 0.173 t CO<sub>2</sub> emissions per tonne of PC produced (Fukuoka, Tojo, Hachiya, Aminaka, & Hasegawa, 2007).

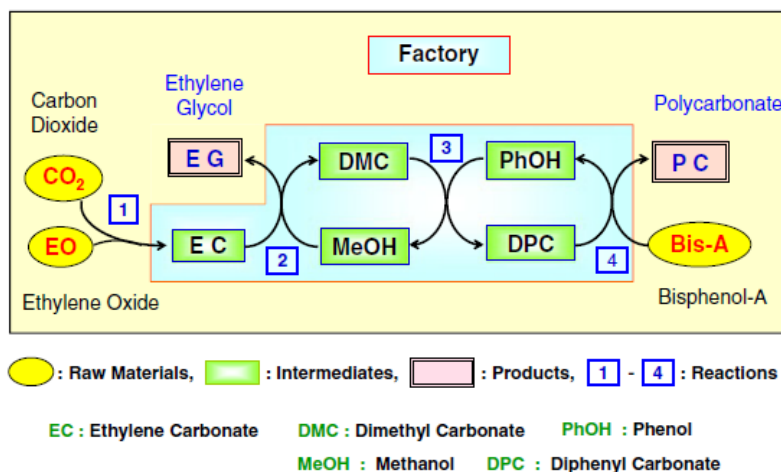

**Figure 17: Phosgene-free production of polycarbonate from CO<sub>2</sub>, BPA and Ethylene Oxide (Fukuoka, Tojo, Hachiya, Aminaka, & Hasegawa, 2007).**

Since 2002, Chimei-Asahi Corp (Taiwan), a joint venture of Asahi Kasei Chemicals and Chi Mei Corp, has a polycarbonate plant using CO<sub>2</sub> as starting material producing around 150 kt of polycarbonate per year. The CO<sub>2</sub> derived polymers are competitive in the market due to the low energy requirements of the process and their high market value provided that the CO<sub>2</sub> feedstock is cheaper than the petroleum it replaces (IEA, 2019).

No information regarding costs and investment requirements is available at this time. As the process is completely different from the phosgene based interfacial process SABIC IP BoZ currently employs, the costs are expected to be significant making it economically unfeasible for SABIC IP BoZ to adopt the phosgene-free, CO<sub>2</sub> capturing technology. However, as the technology is highly relevant for future polycarbonate production and capable of storing CO<sub>2</sub> in chemical products, it should be mentioned in this report.

## 4.3 Process design

### 4.3.1 Mechanical Vapour Recompression

In several of SABIC IP BoZ's production plants distillation and evaporation processes occur. During conventional evaporation and distillation, the energy content of the produced vapour steam is largely lost as the vapours are blown off (GEA, n.d.). Re-use of this waste heat contributes to increased energy efficiency. Mechanical vapour recompression (MVR) heat pumps can be used to recover the vapours and energy they contain. Table 19 lists the properties of MVR heat pumps.

MVR can be applied to the distillation process, where the heat of condensing of the separated distillation vapours is used as a heat source for the distillation process (Berenschot, Energy Matters, CE Delft, & Industrial Energy Experts, 2017). MVR could be applied in the Bisphenol A plant and in the Chlorine plant for caustic soda vaporization (Scherpbier & Eerens, 2021).

**Table 17: Characteristics of MVR** (Marsidi & Lensink, 2020).

Characteristics	Value
<b>Fuel</b>	Steam, waste heat (3 bar, 138 °C)
<b>Energy output</b>	Steam (10 bar, 184 °C)
<b>Emissions</b>	0 tCO <sub>2</sub>
<b>Capacity</b>	5 MW <sub>th</sub>
<b>Full load hours</b>	8000 h/yr
<b>Electricity use</b>	714 kW <sub>e</sub>
<b>Lifetime</b>	10 yr
<b>TRL</b>	9
<b>Investment cost</b>	1602 €/kW <sub>th</sub>
<b>Operational cost</b>	18 €/kW <sub>th</sub> /yr Fixed operational costs 0.008 €/kWh/yr Variable operational costs

### 4.3.2 Zero-gap membrane electrolyser

As mentioned previously in the MIDDEN report about the chlor-alkali industry, the electricity use of a chlorine plant can be lowered by using zero-gap membrane electrolysers (Scherpbier & Eerens, 2021). In zero-gap membrane electrolysers the electrodes are brought very close together (distance between the electrodes < 0.1 m), minimizing the voltage drop across the electrolyte and thus saving energy (Brinkmann, Santonja, Schorcht, Roudier, & Sancho, 2014).

Due to the energy saving potential, zero-gap technology is an attractive long-term investment. Changing the current electrolyzers to zero-gap membrane electrolyzers requires a considerable upfront investment as well as significant maintenance costs (Table 20) (Scherpbier & Eerens, 2021).

**Table 18: Characteristics of a zero-gap membrane electrolyser** (Scherpbier & Eerens, 2021).

Characteristics	Value
<b>Electricity input</b>	6.7 GJ/t Cl <sub>2</sub>
<b>Output</b>	1 tCl <sub>2</sub>
<b>Lifetime</b>	10 yr
<b>TRL</b>	9
<b>Investment cost</b>	102,000 €/t Cl <sub>2</sub>
<b>Operational cost</b>	15,300 €/t Cl <sub>2</sub>

### 4.3.3 Other process efficiency improvements

Annual process efficiency improvements in industry in the Netherlands are around 2% (RVO, 2018). Process efficiency improvements are mostly gained from heat recovery and integration as well as optimization of motors and driven systems (Fawkes, Oung, & Thorpe, 2016).

Between 44-45% of all the energy consumed in the chemical industry is used in separations. Particularly distillation is an energy-intensive process, consuming 49% of the separation energy. Drying is also an energy-intensive process, accounting for 20% of the total energy for separation. Replacing thermochemical separation processes such as distillation by mechanical membrane-based separations requires 90% less energy (Sholl & Lively, 2016). In the BPA plant distillation/dehydration processes require significant energy inputs. Membranes selective towards phenol exist and have been demonstrated in the removal of phenol from water-acetone-phenol mixtures in wastewater. However, the membrane is not yet available on a commercial scale (Kujawski, et al., 2014). Innovative catalysts could also lower the energy demand by reducing the reaction temperature in distillation and separation (Gerres, Chaves-Avila, Linares Llamas, & Gomez San Roman, 2019). Alternatively, electromagnetic radiation could be used in drying processes (Berenschot, Energy Matters, CE Delft, & Industrial Energy Experts, 2017).

## 4.4 Recycling

In the Netherlands about 40% of plastics are recycled and 58% incinerated (CE Delft, 2019). Recycling of materials that have already been produced could be an effective way to reduce plastic waste, greenhouse gas emissions and the consumption of valuable resources. Plastic waste occurs during production and at the products' end of life, so pre-consumer and post-consumer. Pre-consumer waste can easily be directly recycled in the production process. Post-consumer waste requires a more elaborate recycling infrastructure. It needs to be collected from the consumer, sorted and recycled. Usually the different steps in the process are carried out by different parties, further complicating the process. Another barrier to the large-scale recycling of plastics is the fact that due to falling oil prices, it is often cheaper to produce new virgin plastic than to recycle what has already been produced (Van Lockhuyzen, 2020).

Various methods for polymer recycling exist. In primary recycling products are used in their original structure. This includes the pre-consumer recycling of scrap materials. Mechanical (secondary) recycling refers to mechanically separating the polymer from other materials and reprocessing by extrusion techniques. The quality of the polymer deteriorates due to mechanical recycling. To maintain a high-quality material, the recycled polymers are blended with virgin polymer (Grigore, 2017). Mechanical recycling is the preferred option for clean plastic wastes, composed of a single type of plastic such as pure polycarbonate (Ullman, 2016). Plastics with additives or blends, such as Cycloy and Valox are much more difficult to recycle. For blended polymeric plastics the chemical recycling method is more suitable. Chemical or feedstock (tertiary) recycling is the process by which monomers or oligomers are recovered by depolymerization. For polycarbonate multiple depolymerization technologies are under development which lead back to the monomer BPA. The BPA can also be further depolymerised to phenolic compounds (Antonakou & Achilias, 2013). The TRL of depolymerization of polycarbonate is at level 3, meaning that there is only experimental proof of concept (MMIP6: Sluiting van industriële ketens, 2019). A drawback of chemical recycling is the difficulty of separating the polymeric materials and the use of toxic chemicals in the process that cause environmental and safety problems (Antonakou & Achilias, 2013). Lastly, plastics can be recycled to recover energy (quaternary recycling). Conventionally, this means that plastics can be burned in a waste incinerator to produce electricity and heat. Another more advanced way to recover energy is pyrolysis. Pyrolyzing PC waste can yield synthesis gas and liquid hydrocarbons to be used for certain fuel applications (Ullman, 2016). Even though primary oil and gas extraction could be saved in this way, this is the least preferable form of recycling since the combustion of these pyrolysis-fuels would result in CO<sub>2</sub> once again. Therefore this option would only count as a decarbonisation method if this CO<sub>2</sub> is captured and stored or used otherwise.

Though recycling could be an interesting decarbonisation pathway for the plastics industry, the role of the plastic manufacturers in the recycling network has yet to be established. The costs for SABIC IP BoZ to build a recycling plant at their production site will be significant.

## 4.5 Product design

In many of its applications, polycarbonate is critical in transforming the functional characteristics of components to end uses. In other words, polycarbonate cannot be replaced by any other material if the same performance is required (PlasticsEurope, n.d.). The unique and tuneable properties of the plastic resins produced at SABIC IP BoZ enable the products to be used for a wide diversity of applications. Consequently, the resin production numbers and number of different applications is expected to increase in the years to come. As such, there is no straight-forward alternative that can serve such a diverse range of applications. Efforts to reduce emissions have been made by SABIC IP BoZ with the development of bio-based polycarbonate and the incorporation of recycled materials into their resins. Further efforts could be made to enhance the durability, re-usability and recyclability of the materials by considering these concepts in the design phase of product development. Though this is very beneficial from an environmental perspective, from an economical perspective it might be undesirable for SABIC IP BoZ as it will decrease their polycarbonate sales. A new business model including a lease construction such as the one Philips employs, selling light rather than light bulbs, might be interesting to explore here (SABIC IP BoZ, 2020a).



## 4.6 Use of residual energy

Heat integration technologies such as mechanical vapour recompression heat pumps discussed in the previous section are an example of re-using residual energy. Alternatively, residual heat could provide a heat source to other industrial companies, horticulture or residential areas. By providing waste heat to heat networks, the amount of European Emission Allowances allocated to SABIC IP BoZ by the NEa could be increased.

SABIC IP BoZ is located in an industrial area, the Theodorushaven, enabling connections between the neighbouring industrial companies for the exchanges of products and energy carriers. For instance, Lamb Weston Meijer requires a large amount of steam that could be provided by SABIC IP BoZ, as SABIC IP BoZ had 1.08 PJ of residual heat available in 2016 (ECN, 2016). The horticulture cluster around Steenbergem could be another consumer of the waste heat generated in the Theodorushaven (van der Velden, 2016). BlueTerra (2019) concluded that even if residual heat is optimally integrated between the industrial companies located in the Theodorushaven, sufficient waste heat remains to heat nearby residential areas. Bergen op Zoom has a local heat network that could be expanded to include more residences as well as heat suppliers (Concept RES West-Brabant, 2020).

Table 21 shows the costs for the use of waste heat from industry in a waste heat network. The investment cost listed includes a 10 km long pipeline from the industry plant to the heat consumer. As the distance from SABIC IP BoZ to the existing heat network in Bergen op Zoom is only 2 km as the crow flies, the investment costs are likely to be lower.

**Table 19: Characteristics for the use of waste heat from industry in an existing heat network (assuming a 10 km pipeline)** (Muller & Lensink, 2020).

Characteristics	Value
Energy source	Waste heat/water
Output capacity	10 MW <sub>th</sub>
Full load hours	6000 h/yr
Electricity use	0.018 kWh/kWh output
Investment cost	1411 €/kW <sub>th</sub>
Operational cost	29 €/kW <sub>th</sub> /yr Fixed operational costs 0.001 €/kWh/yr Variable operational costs

## 4.7 CO<sub>2</sub> capture and storage or re-use

A way to achieve deep decarbonisation while continuing the use of fossil fuels is by adding carbon capture technology to existing installations. The carbon capture installations remove the CO<sub>2</sub> from exhaust gases, drastically lowering CO<sub>2</sub> emissions. The captured CO<sub>2</sub> can be stored underneath the Earth's surface in geological formations such as emptied oil and gas fields. Alternatively, as described in a former paragraph, the CO<sub>2</sub> could also be used as a raw material in chemical processes to synthesise fuels or polymers (IEA, 2019).

Various technologies exist for capturing CO<sub>2</sub>. They can be divided in three main categories; pre-combustion, post-combustion and oxyfuel combustion. In pre-combustion capture, fuel is first converted to syngas (H<sub>2</sub> and CO). By addition of steam, the syngas is then converted to CO<sub>2</sub> and H<sub>2</sub> after which the CO<sub>2</sub> is removed using solvents or membranes. The leftover H<sub>2</sub> is combusted as fuel and thus requires the CHP to be able to use hydrogen as fuel. In post-combustion, the CO<sub>2</sub> is removed from the flue gas, often by chemical absorption. In oxy-fuel combustion the fuel is burned in a pure oxygen atmosphere resulting in a flue gas consisting of only CO<sub>2</sub> and water. The CO<sub>2</sub> is separated by condensing the water (Abu Zahra, 2009).

Of the three technologies, post-combustion capture is the most mature (Abu Zahra, 2009). The CHP at SABIC IP BoZ is a 132 MWth gas turbine (European Environment Agency, 2019). Gas turbines typically have a flue gas CO<sub>2</sub> concentration of 3-4% (IEA GHG, 2007). For post-combustion capture, this concentration is quite low. Though several technologies exist that can increase the CO<sub>2</sub> concentration of the flue gas, they have not all been demonstrated and come at high costs (Diego, Akram, Bellas, Finney, & Pourkashanian, 2017). Pre-combustion capture could be applied; however, it requires the natural gas burners to be retrofitted to hydrogen also requiring significant investments. Oxyfuel combustion might be the most suitable capture system for gas turbine CHPs, but requires energy-intensive air separation units (ter Telgte, 2012). In theory, any of the three capture technologies could be applied, however, the costs will be significant. Not to mention additional costs for the connection to and development of a CO<sub>2</sub> network. As there are no storage locations for CO<sub>2</sub> in the Bergen op Zoom area, the installation has to be connected to the Porthos project in Rotterdam requiring large investments to facilitate the transport of CO<sub>2</sub> (BlueTerra, 2019). This raises the question whether the high investments costs will be returned by adding CCS to a gas turbine CHP (BlueTerra, 2018).

Table 22 shows the characteristics including the costs of adding a CO<sub>2</sub> post-combustion capture installation to an existing CHP installation at a refinery. Although the assumed capacity of this reference CHP is unknown it is assumed that its capacity and size is in the same order of magnitude as the CHP of SABIC IP BoZ.

**Table 20: Characteristics CCS (Noothout & Lensink, 2019).**

Characteristics	Value
<b>Capacity</b>	0.16 Mt CO <sub>2</sub> capture/year
<b>Full load hours</b>	8000 hours
<b>Heat for CO<sub>2</sub> capture</b>	3.3 GJ/t CO <sub>2</sub>
<b>Electricity use for CO<sub>2</sub> capture and compression</b>	0.1 MWh <sub>e</sub> /t CO <sub>2</sub>
<b>Lifetime</b>	15 years
<b>Investment cost – capture + compression</b>	75.1 mln €
<b>Investment cost – connection to transport network</b>	1 €/tCO <sub>2</sub> /km
<b>Operational cost</b>	1.5 mln €/year Fixed operational costs 23.3 €/t CO <sub>2</sub> Variable operational costs
<b>Treatment allowance (costs for using the CO<sub>2</sub> transport and storage network)*</b>	15 €/t CO <sub>2</sub> storage tariff 45 €/t CO <sub>2</sub> transport tariff

\* These costs were updated in the SDE++ concept advice for CCS in 2020, see Lamboo & Lensink (2020)

For SABIC IP BoZ two important options for CO<sub>2</sub> utilization exist as polycarbonate can be produced using CO<sub>2</sub> as starting material. This option is discussed in paragraph 4.2 related to feedstock substitution.

# 5 Discussion

To effectively decarbonise SABIC IP BoZ, the current natural gas-fired CHP needs to be substituted or adapted. Alternative technologies for heat generation included in this work include fuel substitutions such as the use of biomass or hydrogen and electrification. Which of the above discussed decarbonisation pathways is most likely to be implemented is largely determined by the future Dutch energy infrastructure. Furthermore, rather than changing the fuel, the CHP could potentially also be adapted to capture emissions using a CCS system.

Based on the costs of the alternative heating systems, biomass (mainly direct-firing biomass to produce high quality steam) seems the most attractive option financially. This is mainly caused by the low price of biomass in comparison to the price of green electricity and green hydrogen. However, it does require a stable supply of sustainably sourced biomass to SABIC IP BoZ. The sustainability of biomass has been the topic of an ongoing debate. To fully power industrial sites using biomass, large quantities of biomass are necessary. As the Netherlands currently cannot produce sufficient biomass, biomass is imported mostly from the United States or Scandinavian countries leading to greenhouse gas emissions from transport. To produce all the biomass, large areas of land are necessary bringing about the issue of competition for land with food production. The use of second- or third-generations of biomass such as wood chips or algae would circumvent this issue. The large-scale cultivation of biomass also raises concerns of biodiversity loss. In the Dutch Climate Agreement, the Dutch government originally devoted a major role to biomass for heat and electricity production. However, the public attitude towards biomass varies widely making it hard to reach consensus about the role of biomass<sup>4</sup>. In reaction to this, the government recently expressed the intention to limit biomass use for heat and electricity applications in favour of high-value applications, such as the production of chemicals and biofuels.

Electrification is another decarbonisation path. The use of electricity as a fuel has received a lot of attention in the last years and is often named as the future of industry. However, electricity is only sustainable if it is produced from sustainable resources such as wind and solar. As these sustainable electricity generation technologies are taking off, their share in the electricity mix is increasing steadily and the price of green electricity is coming down. Having industry switch to all-electric would significantly increase electricity requirements. This does not only concern the production of electricity from wind and solar, the Dutch electricity net would also have to be adapted to sustain the increased use of electricity. Additionally, energy storage systems need to be improved and production adjusted to deal with the flexible supply and price of electricity supply as both wind and solar are non-constant sources of energy generation. The role of the public in electrification concerns the public perception of wind and solar parks in their proximity. Though the public is generally supportive and understands the importance of green electricity, they prefer it not to be generated in their backyards. Therefore it is likely that in the future, a large part of the electricity will come from offshore wind.

The concerns regarding the use of hydrogen as a main fuel source relate to those concerning electrification as large amounts of green electricity are necessary to produce green hydrogen. Currently, the price of blue and green hydrogen is too high for the use of hydrogen to be cost-effective. An increasing price for CO<sub>2</sub> could favour the use of hydrogen in the future. As the costs for importing blue and green hydrogen are currently high and an

---

<sup>4</sup> For more insight in this debate and the controversies around biomass see the 2020 report published by PBL *Beschikbaarheid en toepassingsmogelijkheden van duurzame biomassa* of Strengers, B. & Elzenga, H.

infrastructure for transport is lacking, SABIC IP BoZ might benefit from producing their own hydrogen on-site though this does require substantial connection costs to support the increased electricity use.

Geothermal energy could provide a long-term sustainable source of energy for SABIC IP BoZ. However, its use depends on the potential of the geothermal source currently under exploration. Furthermore, a geothermal well has a finite lifetime and must at some point in time be renewed at a different location. Also, the heat as supplied by the geothermal source is insufficient to power all of SABIC IP BoZ's processes. This would require the geothermal source to be used alongside another heating technology for the generation of high temperature heat.

Barriers to the implementation of CC(U)S include the fact that the flue gas might not contain a high enough concentration of CO<sub>2</sub> to make the technology financially viable. In addition, there are no storage facilities in the Bergen op Zoom area, requiring significant costs to connect the site to the Porthos project or to transport the CO<sub>2</sub> by ship. Alternatively, CO<sub>2</sub> could be used as a feedstock at the production site. However, as the process to produce polycarbonate from CO<sub>2</sub> as a feedstock is completely different from the phosgene based interfacial process SABIC IP BoZ currently employs, the costs are expected to be significant making it economically unfeasible for SABIC IP BoZ to adopt the phosgene-free, CO<sub>2</sub> capturing technology. Finally, CCS does not fundamentally change the current fossil fuelled energy system, making it unattractive in the long run. CCS might lead to a lock-in in fossil fuels hampering the transition to a fully renewable energy system.

As detailed information regarding the production processes was lacking, process specific decarbonisation options identified in this work are limited. In general, energy efficiency improvements in the chemical industry are to be gained from improved separation technologies using catalysts and membranes. Additional energy efficiency improvements are to be achieved from heat integration. Many of the reactions occurring at SABIC IP BoZ are exothermic, meaning that heat is released in the process. This waste heat could be used to generate steam or to heat other processes. Mechanical vapour recompression installations or other types of heat pumps could be employed to upgrade waste heat to higher temperatures. Lastly, electricity can be saved by replacing the current electrolyzers in the chlorine plant by zero-gap electrolyzers.

Significant CO<sub>2</sub> emissions could also be avoided by replacing fossil naphtha with renewable bio-naphtha. As the bio-based phenol derived from the bio-naphtha is chemically identical to its fossil fuel-based counterparts, it functions as drop-in replacement that requires no changes to existing processing plants. Bio-based naphtha could be imported from an external source and bio-based polycarbonate could be synthesised at the Bergen op Zoom site.

For plastics, recycling is often put forward as a promising decarbonisation alternative. SABIC IP BoZ has the ability to incorporate recycled materials in their production processes. However, to maintain the high performance of the resins the recycled material has to be of high purity and needs to be blended with virgin polymer, limiting the recycled content to 10-20% (SABIC IP BoZ, 2020a). Other barriers to large-scale recycling are of regulative nature. Though decreasing, large amounts of plastic waste are still being exported to Asian countries limiting the availability of plastic waste in the Netherlands for recycling (CBS, 2019). Additionally, emission savings from recycling concern the scope 3 emissions (emissions related to the company's value chain beyond scope 1 and 2) and do not credit all companies involved in the recycling chain. For recycling and circularity to be successful effort from end-users is required as well. In the recycling infrastructure close collaboration between plastic manufacturers and plastic waste collectors and recyclers is necessary.

# 6 References

- Abu Zahra, M. R. (2009). *Carbon Dioxide Capture from Flue Gas. Development and Evaluation of Existing and Novel Process Concepts*. TU Delft.
- Air Liquide. (n.d.). *Large Industries*. Retrieved from <https://industrie.airliquide-benelux.com/belgie-nederland/levering-industriële-medische-gassen/gas-large-industry>
- Ali, Y. (2019, December 16). *Fit for the Future: Hamburg's Hydrogen Fueled Combined Heat and Power Plant*. Retrieved from <https://microgridknowledge.com/hydrogen-fueled-chp/>.
- American Chemistry Council. (2018). *Properties of Phosgene*. American Chemistry Council.
- Antonakou, E. V., & Achilias, D. S. (2013). Recent Advances in Polycarbonate Recycling: A Review of Degradation Methods and Their Mechanisms. *Waste Biomass Valor.*
- Bauer, F., Ericsson, K., Hasselbalch, J., Nielsen, T., & Nilsson, L. J. (2018). *Climate innovations in the plastic industry: Prospects for decarbonisation*. Environmental and Energy Systems Studies, Department of Technology and Society. Lund University.
- Berenschot, Energy Matters, CE Delft, & Industrial Energy Experts. (2017). *Electrification in the Dutch process industry*.
- Biron, M. (2013). *Thermoplastics and Thermoplastic composites*. Elsevier.
- BlueTerra. (2018). *Toekomstvisie WKK. De nieuwe rol van WKK in een veranderend energielandschap*. BlueTerra.
- BlueTerra. (2019). *Verduurzaming Brabantse industrie*.
- BlueTerra. (n.d.). *Energie Consumptie Analyse bij Sabic Innovative Plastics*. Retrieved from <https://blueterra.nl/project/energie-consumptie-analyse-bij-sabic-innovative-plastics/>
- Boots, M., Wolbers, P., & Lensink, S. (2020). *Conceptadvies SDE++ 2021 Vergisting van biomassa*. Den Haag: PBL.
- Brinkmann, T., Santonja, G. G., Schorcht, F., Roudier, S., & Sancho, L. D. (2014). *Best Available Techniques (BAT) Reference Document for the production of Chlor-alkali*. European Commission.
- Brunelle, D. J., & Korn, M. R. (2005). *Advances in Polycarbonates*. New Orleans: American Chemical Society.
- CBS. (2019, 03 13). *Steeds minder recyclebaar plastic afval naar China*. Retrieved from <https://www.cbs.nl/nl-nl/nieuws/2019/11/steeds-minder-recyclebaar-plastic-afval-naar-china>.
- CBS. (2020). *Rendement en CO2-emissie elektriciteitproductie 2018*. Retrieved from <https://www.cbs.nl/nl-nl/maatwerk/2020/08/rendement-en-co2-emissie-elektriciteitproductie-2018>.
- CE Delft. (2018). *Roadmap towards a climate neutral industry in the Delta region*. Delft: CE Delft.
- CE Delft. (2019). *Plasticgebruik en verwerking van plastic afval in Nederland*.
- Coe, J. T. (2000). *Unlikely Victory: How General Electric Succeeded in the Chemical Industry*. New York: the American Institute of Chemical Engineers.
- (2020). *Concept RES West-Brabant*.
- Cotarca, L., & Eckert, H. (2003). *Phosgenations - A Handbook*. Wiley-VCH.
- Cremers, M., Strengers, B., Beurskens, L., & Lensink, S. (2020). *Conceptadvies SDE++ 2021 Verbranding en vergassing van biomassa*. Den Haag: PBL.
- Czub, P. (n.d.). Bisphenol-A. In S. Thomas, & P. M. Visakh, *Handbook of Engineering and Specialty Thermoplastics*. Scrivener Publishing LLC.
- de Brouwer, H., & Kamps, J. (2008). *Biobased Lexan and Cycloxy resins*. SABIC.

- de Bruyn, S., Jongsma, C., Kampman, B., Gorchach, B., & Thie, J.-E. (2020). *Energy-intensive industries. Challenges and opportunities in energy transition*. Luxembourg: Policy Department for Economic, Scientific and Quality of Life Policies, European Union.
- Diego, M. E., Akram, M., Bellas, J.-M., Finney, K. N., & Pourkashanian, M. (2017). Making gas-CCS a commercial reality: The challenges of scaling up. *Greenhouse Gases: Science and Technology*, 7(5).
- Dijkgraaf, A. (2007, May 21). GE plastics verkocht aan Sabic. C2W.
- DWA. (2008). *Inventarisatie reststromen West-Brabant. Moerdijk, Roosendaal, Bergen op Zoom, Halderberge en Steenbergen*.
- E4tech, UCL Energy Institute, & Kiwa. (2015). *Scenarios for deployment of hydrogen in contributing to meeting carbon budgets and the 2050 target*. London: E4tech.
- ECN. (2016). *Quickscan Warmte Noord-Brabant*.
- Eijsbouts, P. (2008). *Layman report Brine recovery - Brine Recovery in the production of polycarbonate*. After-LIFE Communication Plan (EN).
- Element Energy, Advisian, & Cardiff University. (2019). *Hy4Heat WP6: Conversion of Industrial Heating Equipment to Hydrogen*. Cambridge: Element Energy.
- euRECIPE. (2006). *Low Energy Plastics Processing*.
- European Environment Agency. (2019). *Plant-by-plant emissions (LCP) and information on derogations*. Retrieved from <https://www.eea.europa.eu/data-and-maps/data/lcp-9/plant-by-plant-emissions-lcp>.
- European Environment Agency. (2020). *Large Combustion Plant database*. Retrieved from [https://www.eea.europa.eu/data-and-maps/data/lcp-9/plant-by-plant-emissions-lcp/lcp\\_db\\_csv](https://www.eea.europa.eu/data-and-maps/data/lcp-9/plant-by-plant-emissions-lcp/lcp_db_csv).
- Europese Commissie. (2018). *Bijlagen bij Gedelegeerde Verordening van de Commissie tot vaststelling van een voor de hele Unie geldende overgangsregeling voor de*. Brussel: Europese Commissie.
- Fawkes, S., Oung, K., & Thorpe, D. (2016). *Best Practices and Case Studies for Industrial Energy Efficiency Improvement - An Introduction for Policy Makers*. Copenhagen: UNEP DTU Partnership.
- Flach, B., & Phillips, S. (2019). *The Dutch Industrial Market for Biomass*. Global Agricultural Information Network.
- Fukuoka, S., Tojo, M., Hachiya, H., Aminaka, M., & Hasegawa, K. (2007). Green and Sustainable Chemistry in Practice: Development and Industrialization of a Novel Process for Polycarbonate Production from CO<sub>2</sub> without Using Phosgene. *Polymer Journal*, 91-114.
- GasTerra. (2019). *Green hydrogen is far too expensive for the moment*. Retrieved from [gasterra.nl/en/news/green-hydrogen-is-far-too-expensive-for-the-moment](https://gasterra.nl/en/news/green-hydrogen-is-far-too-expensive-for-the-moment).
- GEA. (n.d.). *Evaporation Technology Using Mechanical Vapour Recompression*.
- General Electric Company. (2002, March 26). *United States Patent No. US 6362304*.
- Gerres, T., Chaves-Avila, J. P., Linares Llamas, P., & Gomez San Roman, T. (2019). A review of cross-sector decarbonisation potentials in the European energy intensive industry. *Journal of Cleaner Production*, 210, 585-601.
- Green Chemistry Campus. (n.d.). *Location*. Retrieved from <https://www.greenchemistrycampus.com/en/about-us/location>
- Grigore, M. E. (2017). Methods of Recycling, Properties and Applications of Recycled Thermoplastic Polymers. *Recycling*.
- IEA. (2019). *Putting CO<sub>2</sub> to Use*. IEA.
- IEA ETSAP. (2010). *Combined Heat and Power*. IEA ETSAP. Retrieved from [https://iea-etsap.org/E-TechDS/PDF/E04-CHP-GS-gct\\_ADfinal.pdf](https://iea-etsap.org/E-TechDS/PDF/E04-CHP-GS-gct_ADfinal.pdf)
- IEA GHG. (2007). *CO<sub>2</sub> capture from medium scale combustion installations*. IEA GHG Programme.

- IHS Markit. (2018). *Polycarbonate Resins*. Retrieved from <https://ihsmarkit.com/products/polycarbonate-resins-chemical-economics-handbook.html>
- in 't Groen, B., Tolsma, S., Mijnlief, H., & Smekens, K. (2020). *Conceptadvies SDE++ 2021 Geothermie*. Den Haag: PBL.
- Klompshouwer, M., Lukszo, Z., & Janssen, F. (2007). Analyzing the relationship between manufacturing lead-times and line flexibility - the Line Flexibility Model. *17th European Symposium on Computer Aided Process Engineering – ESCAPE17*. Elsevier.
- Kujawski, W., Warszawski, A., Ratajczak, W., Porebski, T., Capala, W., & Ostrowska, I. (2014). Application of pervaporation and adsorption to the phenol removal from wastewater. *Separation and Purification Technology*, 40, 123-132.
- Kunststof & Rubber. (2021, January 12). *Richtprijzen kunststoffen week 2*. Retrieved January 18, 2021, from <https://www.kunststofenrubber.nl/>: <https://www.kunststofenrubber.nl/nieuws/id6256-richtprijzen-kunststoffen-week-2.html>
- Lamboog, S., & Lensink, S. (2020). *Conceptadvies SDE++ 2021 CO2-afvang en -opslag (CCS)*. Den Haag: PBL.
- Lappalainen, M. (2019). *Techno-economic feasibility of hydrogen production via polymer membrane electrolyte electrolysis for future power-to-x systems*. Tampere University.
- Mark, H. F. (2004). *Encyclopedia of Polymer Science and Technology*. Wiley-Interscience.
- Marsidi, M. (2018). *Technology Factsheet Large-scale Alkaline-Electrolysis Hydrogen Installation*. ECN TNO. Retrieved from <https://energy.nl/wp-content/uploads/2019/05/FINAL-Factsheet-Large-scale-H2-Alkalische-Elektrolyse.pdf>
- Marsidi, M. (2019a). *Technology Factsheet Electric Industrial Boiler*. ECN & TNO. Retrieved from <https://energy.nl/wp-content/uploads/2018/12/Technology-Factsheet-Electric-industrial-boiler-1.pdf>
- Marsidi, M. (2019b). *Technology Factsheet Polymer Electrolyte Membrane (PEM) Hydrogen Installation - Large-scale*. ECN TNO. Retrieved from <https://energy.nl/wp-content/uploads/2019/01/Polymer-electrolyte-membrane-PEM-hydrogen-installation-%E2%80%93-large-scale.pdf>
- Marsidi, M., & Lensink, S. (2020). *Conceptadvies SDE++ 2021 Grootchalige Elektrische Boilers*. Den Haag: PBL.
- Marsidi, M., & Lensink, S. (2020). *Conceptadvies SDE++ 2021 Grootchalige warmtepompen*. Den Haag: PBL.
- Mehta, R. (2020, June 24). Personal communication.
- Ministerie van Economische Zaken en Klimaat. (2019, December 20). Besluit verlenen opsporingsvergunning aardwarmte West-Brabant. *Staatscourant*. (2019). *MMIP6: Sluiting van industriële ketens*.
- Mota, R. D. (2018). *SABIC's Functional Forms Plant Mass Balance, Production and Waste Analysis, and Sawdust Removal and Elimination*. Instituto Superior de Engenharia de Coimbra.
- Muller, M., & Lensink, S. (2020). *Conceptadvies SDE++ 2021 Benutting restwarmte uit industrie of datacenters*. PBL.
- NEa. (2020). *Emissiecijfers 2013-2019*. Retrieved from <https://www.emissieautoriteit.nl/onderwerpen/rapportages-en-cijfers-ets/documenten/publicatie/2020/04/16/emissiecijfers-2013---2019>
- NEa. (2020, February 2020). *Free allocation of emission rights to Dutch companies*. Retrieved from <https://www.emissieautoriteit.nl/onderwerpen/toewijzing-ets/documenten/hulpdocument/2014/12/08/overzicht-toewijzing-gratis-emissierechten>.
- Neagu, L. (1998). *Synthesis of Bisphenol A with Heterogeneous Catalysis*.

- Negri, A., & Ligthart, T. (2021). *Decarbonisation options for the Dutch polyolefins production*. PBL & TNO.
- Noothout, P., & Lensink, S. (2019). *Conceptadvies SDE++ CO2-reducerende opties: CO2-afvang en -opslag (CCS)*. The Hague: PBL.
- Oliveira dos Santos, C., & van Dril, T. (2021). *Decarbonisation options for the production of Large Volume Organic Chemicals, Geleen*. PBL & TNO.
- Omgevingsdienst Brabant Noord. (2016). Vergunningsaanvraag Z/006292-31827-PRO.
- PBL. (2019). *Klimaat- en Energieverkenning 2019*. Den Haag: PBL.
- PBL. (2020). *Klimaat- en Energieverkenning 2020*. Den Haag: PBL.
- Peeters, E. (2020, April 22). *SABIC maakt door de coronacrisis meer kunstglasplaten dan ooit: 'Het is echt alle hens aan dek'*. Retrieved from Omroep Brabant: <https://www.omroepbrabant.nl/nieuws/3193021/sabic-maakt-door-de-coronacrisis-meer-kunstglasplaten-dan-ooit-het-is-echt-alle-hens-aan-dek>
- PlasticsEurope. (2019a). *Eco-profile Bisphenol A (BPA)*. Brussels.
- PlasticsEurope. (2019b). *Eco-profile Polycarbonate*. Brussels.
- PlasticsEurope. (n.d.). *Polycarbonate in the Netherlands: A major contributor to the country's economy and quality of life*.
- Platform Geothermie, DAGO, Warmtenetwerk, & EBN. (2018). *Master Plan Geothermal Energy in the Netherlands*.
- Power Engineering International. (2010). *Fusina: Achieving low NOx from hydrogen combined-cycle power*. Retrieved from <https://www.powerengineeringint.com/world-regions/europe/fusina-achieving-low-nox-from-hydrogen-combined-cycle-power/>.
- RVO. (2018). *Resultatenbrochure convenanten. Meerjaren afspraken energie-efficiëntie*.
- Ryan, T., Ryan, C., Seddon, E., & Seddon, K. (1996). *Phosgene and related carbonyl halides*. Amsterdam: Elsevier Science.
- SABIC. (2019a). *Toward a vibrant future. Annual report 2019*.
- SABIC. (2019b). *SABIC first in industry to launch polycarbonate based on certified renewable feedstock*. Retrieved from <https://www.sabic.com/en/news/21603-sabic-first-in-industry-to-launch-polycarbonate-based-on-certified-renewable-feedstock>.
- SABIC Bergen op Zoom. (n.d. (a)). *Profiel site Bergen op Zoom*. Retrieved from <http://sabic-bergenopzoom.nl/nl/sabic-bergen-op-zoom/profiel-site-bergen-op-zoom>
- SABIC Bergen op Zoom. (n.d. (b)). *Productaanbod*. Retrieved from <http://www.sabic-bergenopzoom.nl/nl/sabic-bergen-op-zoom/productaanbod>
- SABIC Bergen op Zoom. (n.d. (c)). *Feiten & Cijfers*. Retrieved from <http://www.sabic-bergenopzoom.nl/nl/sabic-bergen-op-zoom/feiten-cijfers>
- SABIC Bergen op Zoom. (n.d. (d)). *Milieu en Duurzaamheid SABIC BOZ*. Retrieved from <http://www.sabic-bergenopzoom.nl/nl/veiligheid-en-milieu/duurzaamheid>
- SABIC Innovative Plastics. (2008). *It's not recycled... It's upcycled. Great resin just got greener*.
- SABIC Innovative Plastics. (2011, November 24). *Omgangsvormen voor Chemische Stoffen bij SABIC IP*. Retrieved from [https://nvab-online.nl/sites/default/files/bestanden-webpaginas/ARBO\\_291\\_Omgangsvormen\\_voor\\_chemische\\_stoffen\\_bij\\_SABIC\\_def\\_2\\_op1bbc3.pdf](https://nvab-online.nl/sites/default/files/bestanden-webpaginas/ARBO_291_Omgangsvormen_voor_chemische_stoffen_bij_SABIC_def_2_op1bbc3.pdf)
- SABIC IP BoZ. (2020b, June 16). Online communication.
- SABIC IP BoZ. (2020c, November 16). Online Communication.
- SABIC IP BoZ. (2020d, August 27). Personal Communication.
- SABIC IP BoZ. (2020e, August 27). Personal communication.
- SABIC IP BoZ. (2020f, November 16). Online Communication.
- SABIC Limburg. (n.d.). *Profiel site Geleen*. Retrieved from <http://www.sabic-limburg.nl/nl/sabic-limburg/profiel-site-geleen>
- SBC Energy Institute. (2014). *Hydrogen-Based Energy Conversion*.
- Scherpbier, E., & Eerens, H. (2021). *Decarbonization options for the Dutch chlor-alkali industry*. Den Haag: PBL.



- Schrama, G. J. (1998). 11. The Internalisation of Environmental Management at GE Plastics Europe. In J. Conrad, *Environmental Management in European Companies Success Stories and Evaluation*. CRC Press.
- Sholl, D. S., & Lively, R. P. (2016). Seven chemical separations to change the world. *Nature*, 532, 435-437.
- ter Telgte, P. (2012). *Prospects of capture and geological storage of CO2 from CHP plants in the Netherlands*. Copernicus Institute. Utrecht University.
- Topsector Energie. (n.d.). *High hydrogen gas turbine retrofit to eliminate carbon emissions*. Retrieved from <https://projecten.topsectorenergie.nl/projecten/high-hydrogen-gas-turbine-retrofit-to-eliminate-carbon-emissions-00031823>.
- Ullman, F. (2007). *Ullman's Encyclopedia of Industrial Chemistry*. Wiley-VCH.
- Ullman, F. (2016). *Ullmann's Polymers and Plastics: Products and Processes*. Wiley-VCH.
- van der Velden, J. (2016). *Warmteplan Brabant*.
- van Hulst, N. (2019). *The clean hydrogen future gas already begun*. Retrieved from <https://www.iea.org/commentaries/the-clean-hydrogen-future-has-already-begun>.
- Van Lockhuyzen, L. (2020, June 8). Recyclers raken plastic niet kwijt. *NRC*.
- Van Luijk, J. A. (2003). *Availability Simulation Modeling in a chemical manufacturing company. A feasibility study by means of the development of a simulation model for the Resin plants of the Lexan production train of GE Plastics*. Faculty of Technology, Policy & Management TU Delft.
- Vautherin, T., & Lopes Cardoso, I. (2019). Bisphenol A in Odontology: Recent data . *Clinical Research and Trials*.
- Verbraeken, H. (2018, February 9). SABIC heropent gesloten fabriek Bergen op Zoom. *FD*.
- Wagner Jr., J. R., Mount III, E. M., & Giles Jr., H. F. (2014). *Extrusion: the definitive processing guide and handbook*. Elsevier.
- Wolbers, P. (2020, October 12). Consultant at DNV GL. Personal communication.

# Appendix A

## A.1 Reference technology

The reference technology for heat and electricity generation is a gas-fired combined heat and power plant with a total energy output of 95 MW in 2018.

**Table 21: Characteristics of SABIC IP BoZ CHP**

Characteristics	Value	Source
<b>Fuel input</b>	Natural gas	
<b>Amount of fuel input</b>	3.45 PJ/year 109 MW	(SABIC IP BoZ, 2020a)
<b>Fuel price</b>	7.5 EUR/GJ	(PBL, 2019)
<b>Fuel costs</b>	26 mln EUR/year	Calculated
<b>Energy output</b>	Steam: 1.91 PJ = 60 MW Electricity: 0.96 PJ = 31 MW Total: 2.96 PJ = 91 MW	(SABIC IP BoZ, 2020a)
<b>Emissions</b>	195.074.000 kgCO <sub>2</sub>	(NEa, 2020)
<b>Input capacity</b>	132 MW <sub>th</sub>	(European Environment Agency, 2019)
<b>Efficiency</b>	83%	Calculated
<b>Full load hours</b>	8760 hours/year	(SABIC IP BoZ, 2020a)
<b>Lifetime</b>	25 years	(IEA ETSAP, 2010)
<b>Investment cost*</b>	950 USD <sub>2008</sub> /kW 967.98 EUR <sub>2020</sub> /kW  128 mln EUR for 132 MW <sub>th</sub> installation	(IEA ETSAP, 2010)  Calculated
<b>Operational cost*</b>	40 USD <sub>2008</sub> /kW/yr 40.76 EUR <sub>2020</sub> /kW/yr  5 mln EUR/year for 132 MW <sub>th</sub> installation 4 mln EUR/year for 95 MW output	(IEA ETSAP, 2010)  Calculated

\* USD<sub>2008</sub> to EUR<sub>2020</sub>. USD<sub>2008</sub> to USD<sub>2020</sub>, 20.89% inflation<sup>5</sup>. 1 USD<sub>2020</sub> = 0.8428 EUR<sub>2020</sub><sup>6</sup>.

<sup>5</sup> Source: <https://www.in2013dollars.com/us/inflation/2008?amount=0.87>

<sup>6</sup> Source: <https://www.exchangerates.org.uk/EUR-USD-spot-exchange-rates-history-2020.html>

## A.2 CHP emission factors calculation

The emission factors from steam and electricity generated by the on-site combined heat and power plant were calculated using the emission attribution method as described in (Europese Commissie, 2018).

$$EF_{CHP,steam} = E_{CHP} \times \frac{A_{CHP,steam}}{Q_{net}}$$

$$EF_{CHP,electricity} = E_{CHP} \times \frac{A_{CHP,electricity}}{EL_{net}}$$

$EF_{CHP,steam}$	= Steam emission factor (kgCO <sub>2</sub> /GJ)
$EF_{CHP,electricity}$	= Electricity emission factor (kgCO <sub>2</sub> /GJ)
$E_{CHP}$	= Emissions from CHP (kgCO <sub>2</sub> )
$A_{CHP,steam}$	= Attribution factor for steam
$A_{CHP,electricity}$	= Attribution factor for electricity
$Q_{net}$	= Net steam output (GJ)
$EL_{net}$	= Net electricity output (GJ)

$$E_{CHP} = EF_i \times F_i$$

$$A_{CHP,steam} = \frac{\frac{\eta_{steam}}{\eta_{ref,steam}}}{\frac{\eta_{steam}}{\eta_{ref,steam}} + \frac{\eta_{electricity}}{\eta_{ref,electricity}}}$$

$$A_{CHP,electricity} = \frac{\frac{\eta_{electricity}}{\eta_{ref,electricity}}}{\frac{\eta_{steam}}{\eta_{ref,steam}} + \frac{\eta_{electricity}}{\eta_{ref,electricity}}}$$

$EF_i$	= Emission factor for fuel i (kgCO <sub>2</sub> /GJ)
$F_i$	= Fuel use (GJ)
$\eta_{steam}$	= Thermal efficiency of CHP = 59%
$\eta_{ref,steam}$	= Reference thermal efficiency = 55%
$\eta_{electricity}$	= Electrical efficiency of CHP = 28%
$\eta_{ref,electricity}$	= Reference electrical efficiency = 25%