



PBL Netherlands Environmental  
Assessment Agency

# METHODS FOR CALCULATING THE EMISSIONS OF TRANSPORT IN THE NETHERLANDS

**Gerben Geilenkirchen et al.**  
14 april 2023

PBL

## Colophon

### **Methods for calculating the emissions of transport in the Netherlands**

PBL Netherlands Environmental Assessment Agency

The Hague, 2023

PBL publication number: 5174

### Corresponding author

Gerben.geilenkirchen@pbl.nl

### Author(s)

Gerben Geilenkirchen, Mark Bolech, Jan Hulskotte, Stijn Dellaert, Norbert Ligterink, Michel Sijstermans, Kathleen Geertjes, Kevin Felter, Maarten 't Hoen

### Acknowledgements

We would like to thank the **Task Force Transportation in the Dutch Pollutant Release and Transfer Register:**

Gerben Geilenkirchen (PBL Netherlands Environmental Agency), Kathleen Geertjes (Statistics Netherlands), Michel Sijstermans (Statistics Netherlands), Astrid Kampert (Statistics Netherlands), Jan Hulskotte (TNO), Emiel van Eijk (TNO), Jessica de Rooter (TNO), Norbert Ligterink (TNO), Mark Bolech (TNO), Stijn Dellaert (TNO), Riekele de Boer, Stefan Valk (RWS Water, Transport and Environment (WVL), Kevin Felter (RIVM), Dirk Wever (RIVM) and Maarten 't Hoen (PBL Netherlands Environmental Agency).

### Accessibility

PBL attaches great importance to the accessibility of its products. Should you encounter any access-related problems when reading them, please contact us at [info@pbl.nl](mailto:info@pbl.nl), stating the title of the publication and the issue you are experiencing.

Parts of this publication may be reproduced, providing the source is stated, in the form:  
Geilenkirchen, G. et al. (2023), *Methods for calculating the emissions of transport in the Netherlands*. The Hague: PBL Netherlands Environmental Assessment Agency.

PBL Netherlands Environmental Assessment Agency is the national institute for strategic policy analysis in the fields of the environment, nature and spatial planning. We contribute to improving the quality of political and administrative decision-making by conducting outlook studies, analyses and evaluations in which an integrated approach is considered paramount. Policy relevance is the prime concern in all of our studies. We conduct solicited and unsolicited research that is both independent and scientifically sound.

# Contents

<b>Colophon</b>	<b>2</b>
Corresponding author	2
Author(s)	2
Acknowledgements	2
Accessibility	2
<b>1 Introduction</b>	<b>6</b>
1.1 Source categories within mobile sources	6
1.2 Reporting requirements and formats	7
1.3 Outline of the report	9
1.4 Uncertainties & QA/QC procedures	9
1.5 Changes in the methodology report	10
<b>2 Greenhouse gas emissions</b>	<b>10</b>
2.1 Sources category description	10
2.2 Methodological issues	12
2.2.1 Domestic aviation	12
2.2.2 Road transportation	12
2.2.3 Railways	17
2.2.4 Domestic navigation and other sectors: fishing	17
2.2.5 Other sectors: Non-road mobile machinery	18
2.2.6 Other sectors: Military use	19
2.2.7 Memo items: International bunkers	19
2.2.8 Fossil carbon in biofuels	19
2.3 Uncertainties and time series consistency	20
<b>3 Road transport</b>	<b>21</b>
3.1 Source category description	21
3.2 Emissions processes and calculation methods	21
3.2.1 Technology dependent exhaust emissions	22
3.2.2 Fuel dependent exhaust emissions	24
3.2.3 Exhaust emissions of VOC and PAH species	25
3.2.4 Evaporative emissions of VOC and VOC components	26
3.2.5 PM emissions resulting from wear of tyres, brakes and road surfaces	28
3.2.6 Leakage of lubricant oil; heavy metals and PAHs	32
3.2.7 Consumption of lubricant oil; heavy metals	32
3.2.8 Refrigeration units on trucks	33
3.2.9 Fuel sold emissions from road transport	34
3.3 Activity data for road transport	34
3.3.1 Cold starts	37
3.3.2 Mopeds and motorcycles	38
3.4 (Implied) Emission Factors for road transport	39
3.4.1 VERSIT+ emission factors for air pollutants	39
3.4.2 Fuel consumption and fuel related emission factors	43
3.4.3 Other emission factors	45

3.4.4	VOC species profiles	45
3.5	Uncertainties	47
3.6	Points for improvement	48
<b>4</b>	<b>Railways</b>	<b>49</b>
4.1	Source category description	49
4.2	Activity data and (implied) emission factors	49
4.2.1	Exhaust emissions from railways	49
4.2.2	Wear of overhead contact lines and carbon brushes	50
4.3	Uncertainties	51
4.4	Points for improvement	51
<b>5</b>	<b>Inland navigation</b>	<b>52</b>
5.1	Source category description	52
5.2	Activity data and (implied) emission factors	53
5.2.1	Professional inland shipping	53
5.2.2	Passenger ships and recreational craft	57
5.2.3	De-gassing cargo fumes to the atmosphere	57
5.3	Uncertainties	58
5.4	Points for improvement	59
<b>6</b>	<b>Fisheries</b>	<b>61</b>
6.1	Source category description	61
6.2	Activity data and (implied) emission factors	61
6.3	Uncertainties	62
6.4	Points for improvement	63
<b>7</b>	<b>Maritime navigation</b>	<b>63</b>
7.1	Source category description	63
7.2	Activity data and (implied) emission factors	64
7.2.1	Emissions of sailing sea-ships	64
7.2.2	Emissions from seagoing vessels at berth	67
7.2.3	Exhaust emissions of SO <sub>2</sub> , N <sub>2</sub> O, NH <sub>3</sub> , heavy metals and VOC/PAH components	69
7.3	Uncertainties	70
7.4	Points for improvement	71
<b>8</b>	<b>Civil aviation</b>	<b>72</b>
8.1	Source category description	72
8.2	Activity data and (implied) emission factors	73
8.2.1	Exhaust emissions at Amsterdam Airport Schiphol	73
8.2.2	Emissions from tyre and brake wear	75
8.2.3	Emissions from auxiliary power units	76
8.2.4	Emissions from ground support equipment	76
8.2.5	Emissions from storage and transfer of jet fuel	77
8.3	Uncertainties	77
8.4	Points for improvement	78
<b>9</b>	<b>Non-Road Mobile Machinery</b>	<b>78</b>

9.1	Source category description	78
9.2	Activity data and (implied) emission factors	79
9.2.1	Activity data	79
9.2.2	Emission factors	83
9.3	Uncertainties	83
9.4	Points for improvement	84
<b>References</b>		<b>86</b>
	Chapter 1	86
	Chapter 2	86
	Chapter 3	87
	Chapter 4	91
	Chapter 5	91
	Chapter 6	92
	Chapter 7	92
	Chapter 8	93
	Chapter 9	94

# 1 Introduction

The sources that cause emissions of environmental pollutants can roughly be divided into stationary and mobile sources. Mobile sources include various means of transport such as passenger cars, heavy-duty trucks, inland waterway vessels and aircraft, as well as mobile machinery with combustion engines, such as agricultural tractors and forklifts. This report describes the methodologies, emission factors and activity data used to calculate the emissions of environmental pollutants from mobile sources in the Netherlands. These emissions are calculated annually by the Task Force Transportation in the Dutch Pollutant Release and Transfer Register (PRTR). The resulting greenhouse gas emissions are reported annually in the National Inventory Report, whereas the air polluting emissions are reported in the Informative Inventory Report. Both inventory reports provide a brief description of the trends in emissions and the methodologies used to calculate emissions. The methodologies and underlying data used are described in detail in the present report.

This report describes the methodologies used for calculating the emissions for the 1990-2021 time series, as reported in the 2023 National Inventory Report (RIVM 2023a) and the 2023 Informative Inventory Report (RIVM 2023b). The report has been compiled by the members of the Task Force Transportation in the PRTR, which includes representatives of Statistics Netherlands, the PBL Netherlands Environmental Assessment Agency, the Netherlands Organisation of Applied Scientific Research TNO and the RWS Water, Transport and Environment (WVL) of the Dutch Ministry of Infrastructure and Navigation. For a more general description of the Dutch PRTR and the different task forces, please refer to the website of the PRTR ([www.emissieregistratie.nl](http://www.emissieregistratie.nl)).

The majority of the tables accompanying this report have been included in a separate Excel file. References to these tables are printed in italics. In addition to the data for the emission calculation, the tables also contain references and hyperlinks to the underlying data sources used for the calculation of the emissions.

## 1.1 Source categories within mobile sources

This report covers the methodologies used for calculating both the greenhouse gas emissions and the emissions of air pollutants by mobile sources in the Netherlands. Mobile sources include:

- Road transportation
- Railways
- Civil aviation
- Inland navigation
- Maritime navigation
- Fisheries
- Non-Road Mobile Machinery
- Military shipping and aviation

For each source category, various processes are distinguished that result in emissions of greenhouse gases and/or air pollutants:

- Combustion of motor fuels for propulsion;
- Evaporation of motor fuels from the fuel system of vehicles;
- Wear of tyres, brake linings and road surfaces;

- Leakage and consumption of motor oil;
- Wear of overhead contact lines and carbon brushes on trains, trams and metros;
- Support systems on board ships (heating, electricity generation, refrigeration and pumping).

This report only covers emissions to air. The emissions to water from mobile sources are reported by the MEWAT task force in the PRTR. This includes emissions to water from:

- Anti-fouling on recreational boats;
- Coatings and bilge water from inland waterway vessels;
- Leakage of propeller shaft grease and spillage from inland waterway vessels;
- Corrosion of zinc anodes on inland waterway vessels and locks;
- Leaching from seagoing vessels and fishery vessels in harbours and national continental shelf;
- Anodes of seagoing vessels and fishery vessels in harbours and on the national continental shelf.

For more information about the methodologies, activity data and emission factors used to calculate the emissions from these emission sources, please refer to the documentation on the PRTR-website.

## 1.2 Reporting requirements and formats

The emissions from the PRTR are used for air quality modelling and for emission reporting to the UN and the EU. Under the UN Framework Climate Change Convention (UNFCCC) and the EU Monitoring Mechanism Regulation (MMR), countries are obliged to annually report national emissions of greenhouse gases. The emissions of air pollutants are reported under the UNECE Convention on Long-Range Transboundary Air Pollution (LRTAP) and the EU National Emission Ceilings Directive (NECD). The reporting guidelines and formats for these reporting obligations differ. The present report covers the methodologies used for both obligations. Greenhouse gas emissions are reported in the annual National Inventory Report (NIR) and the accompanying 'Common Reporting Format' (CRF) tables, based on the reporting obligations and guidelines from the 2006 IPCC Guidelines (IPCC 2006). Emissions from air pollutants are reported in the Informative Inventory Report (IIR) and the accompanying tables, using the 'Nomenclature For Reporting' (NFR) and the UNECE Guidelines for reporting emissions and projections data under the LRTAP convention (UNECE 2015). The CRF and NFR codes used to report emissions for the different source categories are mentioned in the different chapters of the present report.

The estimates of emissions from mobile sources are also used for air quality monitoring. For these purposes, emissions are estimated for the Dutch national territory. Where methodologies for calculating emissions on national territory differ from methodologies used to calculate official greenhouse gas (CRF) and air pollutant (NFR) emissions, this is described in chapters 3 to 9. Table 1A gives a short overview of the emissions included in the different reporting obligations.

For *civil aviation*, the CRF includes greenhouse gas emissions from domestic aviation, i.e. all flights that both depart and arrive in the Netherlands. Emissions from international aviation, with either departure or arrival abroad, are reported as a memo item and are not included in the national totals. Emissions are calculated based on the amount of fuel supplied to national and international aviation. The NFR includes emissions from both national and international aviation, but only throughout the Landing and Take-off cycle (LTO). Cruise emissions are not included in the national

totals. Air quality modelling also uses the LTO-emissions from air pollutants by civil aviation, as reported in the NFR.

**Table 1A**  
Emissions included in different reporting obligations

Source category	Greenhouse gases (CRF)	Air pollutants (NFR)	Air pollutants (air quality modelling)
<b>Civil aviation</b>	Domestic only; LTO <sup>1</sup> & cruise. International aviation as memo item	Domestic & international; LTO <sup>1</sup> only	Domestic & international; LTO <sup>1</sup> only
<b>Road Transportation</b>	Based on fuel sold in NL	Based on fuel sold in NL	Based on fuel used in NL
<b>Railways</b>	Based on fuel sold in NL	Based on fuel sold in NL	Based on fuel sold in NL
<b>Water-borne inland navigation</b>	Domestic only. International memo item	All emissions on Dutch national territory	All emissions on Dutch national territory
<b>Non-Road Mobile Machinery</b>	Based on fuel used in NL	Based on fuel used in NL	Based on fuel used in NL
<b>Fishing</b>	Based on fuel sold in NL	Based on fuel sold in NL	Based on fuel used in NL
<b>Military aviation and shipping</b>	Based on fuel sold in NL	Not included separately	Not included separately
<b>Maritime navigation</b>	Memo item; based on fuel sold	Memo item; based on fuel used	Based on fuel used

<sup>1)</sup> LTO: Landing and Take-Off

Blue = based on fuel sold; Orange = based on fuel used on Dutch national territory

For *road transport* and *railways*, both the CRF and the NFR include emissions resulting from the fuel supplied to road transport and railways in the Netherlands. The activity data for both reporting obligations are identical. Since some of this fuel is used abroad, the emission totals are not suited for air quality modelling. For air quality modelling the emissions from road transport are derived using statistics on vehicle kilometres driven (and resulting fuel used) in the Netherlands. For railways there is no bottom-up calculation of air pollutant emissions in the Netherlands due to the lack of activity data on train kilometres driven. Air quality modelling therefore uses the same emission totals for railways as reported in the NFR.

For *inland navigation*, the CRF includes greenhouse gas emissions from domestic navigation, i.e. all voyages that both depart and arrive in the Netherlands. Emissions from international navigation, with either departure or arrival abroad, are reported as a memo item and are not included in the national totals. The NFR includes all emissions of air pollutants from inland navigation within Dutch national territory, including the emissions from international navigation. As such, the activity data differ for both reporting obligations. The NFR emission totals are also used for air quality modelling.

For *fisheries*, both the CRF and the NFR include emissions resulting from the fuel deliveries to



fisheries in the Netherlands (i.e. fuel sold). Not all emissions resulting from these fuel deliveries take place on Dutch national territory. Specifically for air quality modelling, emissions of air pollutants are estimated on the Dutch part of the North Sea.

For *non-road mobile machinery* (NRMM), both the CRF and the NFR include emissions resulting from all fuel used by NRMM in the Netherlands. Since fuel sales to NRMM are not reported separately in the Energy Balance, fuel consumption is estimated using a modelling approach. To ensure consistency with national energy statistics, the total fuel sales data from the Energy Balance (including sales to both road transport and NRMM) are adjusted accordingly. Emission totals from the NFR are also used for air quality modelling.

Emissions from *maritime navigation* are reported as a memo item in both the CRF and the NFR, but the activity data differ between both reporting obligations. The CRF includes total fuel sold (and resulting emissions) to maritime navigation in the Netherlands, regardless of where the fuel is used. The NFR includes the emissions of air pollutants by maritime shipping on the Dutch part of the North Sea, regardless of whether or not the fuel used was delivered in the Netherlands or abroad. The emission estimates from the NFR are also used for air quality modelling.

Emissions from *military aviation and navigation* are included in the CRF, based on the fuel deliveries for military purposes in the Netherlands. The NFR does not include emissions from military aviation or shipping due to a lack of data on number of flights and voyages and the types of air planes and ships used. Due to this lack of emissions estimates, emissions from military aviation and shipping are also not included in air quality modelling.

## 1.3 Outline of the report

This report describes the methodologies and underlying data used to estimate emissions from mobile sources in the Netherlands. Chapter two covers the methodologies used for calculating emissions of greenhouse gases by mobile sources. The remaining chapters cover the methodologies used for calculating emissions of air pollutants by the different source categories. Each of these chapters starts with a description of the specific source category and the processes that lead to emissions. This is followed by a description of the activity data and (implied) emission factors, the uncertainty estimates and the points for improvement. The (trends in the) emission totals for the different source categories and the source-specific recalculations are described annually in the NIR and IIR. The present report only covers the methodologies used. A general description of the PRTR QA/QC program is given in paragraph 1.5 below. Source-specific QA/QC procedures are described in the NIR and IIR.

## 1.4 Uncertainties & QA/QC procedures

The reporting guidelines for emissions of both greenhouse gases and air pollutants require Parties to quantify uncertainties in their emission estimates. The uncertainty estimates for emissions from mobile sources are covered in the present report. Uncertainty estimates for greenhouse gas emissions have been quantified and are described in Chapter 2.3. For air pollutants, uncertainty estimates per source category are presented in chapters 3 to 9.

The annual work plan of Dutch PRTR includes a description of QA/QC processes that will be carried

out before emissions can be finalized. The QA/QC procedures of the PRTR focus on consistency, completeness and accuracy of the emission data. The general QA/QC for the inventory is largely performed within the PRTR as an integrated part of the work processes.

## 1.5 Changes in the methodology report

The present report is published each year as an annex to the National Inventory Report and the Informative Inventory Report. In this report the state-of-the-art methodology used for calculating transport emissions in the Netherlands is described. Every year there are several updates in methodology, resulting from improved insights, more accurate calculation methods and updated measurements of emission factors.

In the present report, the following changes were implemented as compared to the previous methodology report:

- description of the activity data for calculation of greenhouse gas emissions as derived from the Energy Balance (2.2.2 and 2.2.5)
- adjusted sources and heating values and CO<sub>2</sub> emission factors for road transport (2.2.2)
- methodology for the calculation of cold start emissions (3.3.1)
- activity data for mopeds and motorcycles (3.3.2)
- inclusion of specific trains that are used for building and maintenance of the railroad network (4.2.1)
- updated methodology for emission calculation of de-gassing cargo fumes to the atmosphere (5.2.3)
- updated methodology for emission calculation of non-road mobile machineries (9.2.1)

## 2 Greenhouse gas emissions

This chapter covers the methodologies used for calculating the greenhouse gas emissions from mobile sources in the Netherlands. Since these methodologies differ from those used for calculating emissions of air pollutants, they are covered in a separate chapter. The emissions of greenhouse gases are reported annually in the National Inventory Report (NIR) and the accompanying 'Common Reporting Format' (CRF) tables, based on the reporting obligations from the 2006 IPCC Guidelines (IPCC 2006).

### 2.1 Sources category description

The greenhouse gas emissions from mobile sources are reported under different sources categories in the CRF, as is shown in Table 2A. Emissions from transport are reported under 1A3, which includes emissions from civil aviation (1A3a), various means of road transportation (1A3b), railways (1A3c) and water-borne navigation (1A3d). Emissions from non-road mobile machinery are reported under different source categories in the CRF, based on the sectors where the machinery is applied:

- Emissions from industrial and construction machinery are reported under 1A2g;
- Emissions from commercial and institutional machinery are reported under 1A4a;
- Emissions from residential machinery are reported under 1A4b;
- Emissions from agricultural machinery are reported under 1A4c.

Emissions from fisheries are reported under 1A4c as well, whereas emissions from military aviation and shipping are reported under 1A5b. Emissions from bunker fuels, delivered to international aviation and international water-borne navigation, are not part of the national emission totals, but instead are reported as a memo item under source category 1D1. Table 2A gives an overview of the methodologies used for calculating the greenhouse gas emissions, with Tier 1 (T1) being the most basic approach and Tier 3 (T3) the most detailed. The table also shows whether the emission factors used are country-specific values (CS) or default values (D) derived from the 2006 IPCC Guidelines.

Source category 1A3a (domestic aviation) includes emissions from domestic aviation in the Netherlands, i.e. all aviation with departure and arrival in the Netherlands. This includes emissions from overland flights which depart from and arrive at the same airport. Emissions from fuel deliveries to international aviation are reported under 1D1a and are not part of the national emission totals. Similarly, source category 1A3d (domestic navigation) only includes emissions from domestic navigation. This includes the emissions from recreational craft, passenger and freight shipping and so-called ‘work-at-sea’ (ships dedicated for maintenance of platforms and wind turbines at sea, generators at sea or dredging and sand spraying ships). Emissions from international water-borne navigation, i.e. navigation with either arrival or departure abroad, are reported as a memo item under 1D1b. Emissions from fisheries are reported separately in the inventory under source category 1A4ciii. In line with the 2006 IPCC Guidelines, all emissions from fishing are part of the national emission totals; there is no international bunker fuel category for commercial fishing, regardless of where the fishing occurs.

**Table 2A**  
Greenhouse gas emission reporting for mobile sources in the CRF

CRF code	Source category description	Methodology	Emission factors*
1D1a	International bunkers (International Aviation)	T1	D
1D1b	International bunkers (International Navigation)	T1, T2	D, CS
1A2gvii	Manufacturing industries and construction, other (Off-road vehicles and other machinery)	T1, T2	D, CS
1A3a	Domestic aviation	T1	D, CS
1A3b	Road Transportation	T2, T3	D, CS
1A3c	Railways	T1, T2	D, CS
1A3d	Domestic Navigation	T1, T2	D, CS
1A4aii	Commercial/Institutional (Off-road vehicles and other machinery)	T1, T2	D, CS
1A4bii	Residential (Off-road vehicles and other machinery)	T1, T2	D, CS
1A4cii	Agriculture/Forestry/Fishing (Off-road vehicles and other machinery)	T1, T2	D, CS
1A4ciii	Fishing	T2	D, CS
1A5b	Mobile (Military use)	T2	D, CS
2D3	Non-energy Products from Fuels and Solvent Use (Other)	T3	CS

\*) CS = country-specific; D = default

Emissions from military aviation and water-borne navigation are reported under source category 1A5b. This includes the emissions resulting from the combustion of jet kerosene and marine fuel for military aviation and navigation. The emissions by the land forces are not reported separately but are included in the emissions by road transport and mobile machinery.

Source category 1A3b (road transportation) includes emissions from motorized road transport in the Netherlands. This includes emissions from passenger cars (1A3bi), light-duty trucks (1A3bii), heavy-duty trucks and buses (1A3biii) and motorcycles and mopeds (1A3biv). It also includes CO<sub>2</sub> emissions from the use of lubricants by two-stroke mopeds and motorcycles. CO<sub>2</sub> emissions resulting from the use of urea-based additives in catalytic converters in road vehicles are reported under source category 2D3. Source category 1A3c (Railways) includes greenhouse gas emissions from diesel fuelled railway transportation.

## 2.2 Methodological issues

Greenhouse gas emissions from mobile sources in the Netherlands are calculated based on the formula:

$$\text{Emission (kg)} = \sum^{\text{Type of fuel}} \text{fuel sales (kg)} * \text{heating value (MJ/kg)} * \text{emission factor (kg/MJ)}$$

The activity data (i.e. the fuel sales per fuel type) are derived from the Energy Balance, as reported by Statistics Netherlands. *Table 2.1* shows the activity data used for the most recent inventory. The heating values and the CO<sub>2</sub> emission factors per fuel type are country-specific, as shown in *Table 2.2A*. The N<sub>2</sub>O and CH<sub>4</sub> emission factors (*Table 2.2B*) for the most part are defaults, the only exception being the emission factors for road transport and non-road mobile machinery, as described below. N<sub>2</sub>O and CH<sub>4</sub> emission factors can be found in *Tables 2.2B* (overview), 2.10 (N<sub>2</sub>O, road transport), 2.11 (CH<sub>4</sub>, road transport) and 9.6 (CH<sub>4</sub>, mobile machinery).

### 2.2.1 Domestic aviation

Greenhouse gas emissions from domestic civil aviation are calculated using a fuel-based Tier 1 methodology. Fuel deliveries for domestic aviation are derived from the Energy Balance. This includes deliveries of both jet kerosene and aviation gasoline. The time-series for deliveries of both jet kerosene and aviation gasoline for domestic aviation are shown in *Table 2.1*. The heating values and CO<sub>2</sub> emission factors for aviation gasoline are derived from the Netherlands' list of fuels (Zijlema 2023) and are based on measurements of gasoline for road transport, as described in the NIR 2019. For jet kerosene a country specific heating value is used derived from Zijlema (2023) combined with the default CO<sub>2</sub> emission factor from the 2006 IPCC Guidelines (IPCC 2006). These values are shown in *Table 2.2A*. For N<sub>2</sub>O and CH<sub>4</sub> default emission factors are used, as shown in *Table 2.2B*. Since civil aviation is a minor source of greenhouse gas emissions in the Netherlands and is not a key source in the inventory, the use of a Tier 1 methodology to estimate emissions is deemed sufficient.

### 2.2.2 Road transportation

According to the 2006 IPCC Guidelines, greenhouse gas emissions from road transport should be attributed to the country where the fuel is sold. Total fuel consumption by road transport therefore should reflect the amount of fuel sold within the country's territory. To comply with this, activity

data for greenhouse gas emissions from road transport are derived from the Dutch national Energy Balance. The Energy Balance includes fuel sales data for gasoline, diesel, Liquefied Petroleum Gas (LPG), natural gas (CNG) and biofuels, as shown in *Table 2.1*. Fuel sales data for gasoline from the Energy Balance are adjusted for the use of gasoline in recreational craft and by NRMM, which are not reported separately in the Energy Balance but are instead included in road transport. In the same manner, LPG sales to road transport from the Energy Balance are adjusted for the use of LPG by NRMM, which is also not reported separately in the Energy Balance. These adjustments are also shown in *Table 2.1*. Diesel for road transport is reported separately in the Energy Balance. There is a distinct time series for diesel consumption in road transport for 1990-2012 (as shown in *Table 2.1*), due to the distinction between high and low tax for diesel fuel (until 2012). As of 2013, final consumption of road transport is calculated in the Energy Balance as the remainder of total supply to the market of diesel minus deliveries to users other than road transport (non-road mobile machineries, inland shipping, recreational shipping, fisheries and rail transport).

Fuel sales data for road transport in the Energy Balance are not reported by vehicle category. Therefore, for emissions reporting, total sales per fuel type are disaggregated to the various vehicle categories (e.g. passenger cars, light duty trucks), using information on fuel consumed on Dutch national territory (fuel used), as calculated bottom-up using vehicle-kilometres travelled per vehicle and the specific fuel consumption per vehicle-kilometre. The fuel sales data are used to calculate total emissions, whereas the bottom-up calculated fuel consumption data are used to split these fuel sales per fuel type among the different vehicle categories included in the CRF. The gasoline consumption of road transport is determined by deducting the (calculated) consumption of recreational craft and NRMM from the sales to road transport according to the Energy Balance. For gasoline we assume the same ratio between fuel sold and fuel used for all vehicle categories. Diesel sales to road transport are registered separately in the Energy Balance (recreational craft and NRMM are not included). The allocation of the diesel fuel sales within road transport to the different vehicle categories is based on the calculated (fuel used) diesel use of passenger cars, light commercial vehicles, buses and the use of two-wheelers. The fuel consumption of heavy duty vehicles is determined by deducting the diesel use in the above vehicle categories from total diesel sales for road transport. This means that the difference between fuel used and fuel sold is allocated solely to heavy duty vehicles. The (bottom-up) calculation of fuel consumption by road transport in the Netherlands is described in detail in Sections 3.3 and 3.4.

The resulting fuel consumption figures differ from fuel sales data due to varying reasons:

- Stockpiling is included in fuel sales data;
- Both approaches (fuel consumption and fuel sales) contain statistical inaccuracies;
- Cross-border refuelling. This concerns fuel purchased in the Netherlands (included in sales) that is used abroad (not included in consumption) or fuel purchased abroad (not included in sales) that is used in the Netherlands (included in consumption).

The resulting differences between fuel used and fuel sold are analysed in more detail in the annual National Inventory Reports (NIR).

### **Heating values and CO<sub>2</sub> emission factors for road transport**

The CO<sub>2</sub> emissions from road transport are calculated using a Tier 2 methodology. Country-specific heating values and CO<sub>2</sub> emission factors are derived from Swertz et al. (2017), as shown in *Table 2.6* and *2.7*. These values were derived from measurement campaigns performed in 2004 (Olivier, 2004), in 2015-2017 (Ligterink, 2016) with a follow-up in 2017-2019 (Ligterink, 2020). The methodology used to derive a consistent time series for both the heating values and CO<sub>2</sub> emission

factors for gasoline and diesel is described in Swertz et al. (2017). A summary is given below.

The composition of both gasoline and diesel has changed throughout the time series, e.g. due to the introduction of leadfree gasoline, the addition of biofuels in the market fuels and the lowering of the sulphur content of the fuels. In 2015, measurements were performed on 25 gasoline and 19 diesel fuel samples (Ligterink, 2016). Samples were collected in both summer and winter at stations representing different brands (including budget stations) and in different regions in the Netherlands. The methods used for sample analysis are described in Ligterink (2016). Due to some outliers in the results, additional measurements were performed in 2017. Fuel samples were collected monthly across the Netherlands, mixed in equal fractions (typically 6 samples, ranging from 4 to 7) and subsequently analysed to estimate monthly averages. In order to construct a consistent timeseries, the following assumptions were made:

- The previously used heating value in the Energy Balance for gasoline of 44.0 MJ/kg was assumed to be applicable to the start of the time series, i.e. 1970. The CO<sub>2</sub> emission factor was assumed to be 3200 g/kg fuel.
- The (average) measurement results from Olivier (2004) were assumed to be applicable to lead-free gasoline without added biofuels, which was measured at the time.
- The decrease of the heating value between 1970 and 2004 was assumed to be resulting from the replacement of lead by other antiknock agents. The decrease of the lead content of gasoline between 1986 and 1997 was used as a proxy to construct a time series.
- The increase in the heating value between 2004 and 2015 was assumed to be resulting from the addition of bioethanol in the market fuel. As such, the increase of the amount of bioethanol added to the market fuel was used as a proxy for the increase of the heating value between 2004 and 2015.

The 2016 study recommended continuous monitoring of gasoline fuels, as bio-admixture and water content can affect the fuel. The follow-up study started in 2017 (Ligterink, 2020) in which petrol and ethanol fuel samples were examined. An additional objective was to investigate the possibility to tune fuels to a lower CO<sub>2</sub> emission (measured in the exhaust flow). In total 68 petrol and 14 ethanol samples were taken during two research phases. The conclusions are as follows:

- The study confirms the finding of the earlier 2016 study, that the water content of E5 petrol is systematically higher than can be expected based on the maximum allowable water content of ethanol. It is on average about 0.1 weight % higher, which would reduce the energy content also by about 0.1%.
- The precise reason for the high water content could not be identified with certainty. According to the phase 1 samples the most likely reason is too high water content in ethanol, but this was not confirmed by the phase 2 samples.
- The E5 fuels showed a small band width in ethanol volume fraction: 4.38% to 4.61%.
- The combustion values of 12 mixed monthly E5 samples showed a range from 42.07 to 42.5 MJ/kg (phase 1). The four fossil fraction of petrol, i.e. EuroBOB1 samples, taken at the refinery, varied from 43.22 to 43.40 MJ/kg.
- The carbon content of the EuroBOB samples ranged from 84.5% to 86.0%.
- The CO<sub>2</sub> emissions can be reduced by approximately 0.7% compared to an average standard reference fuel by optimizing the fuel for lower specific CO<sub>2</sub> emissions.

For more detail about the research phases, see Ligterink's report (2020).

For diesel fuel, the heating value of fossil diesel is based on the 2004 measurements (43.1 MJ/kg) and the 2015 measurements (43.2 MJ/kg). The heating value of 42.7 MJ/kg (which was used in inventory reports before 2018) was assumed to apply to the situation in 1970. The change in the heating values during 1970–2015 has been determined on the basis of the heating value-reducing

sulphur content (Swertz et al., 2017). The carbon content of diesel fuel measured in 2004, which leads to a fixed CO<sub>2</sub> emission factor of 3170 g/kg, has been applied for the entire period 1970–2004. The average CO<sub>2</sub> emission factor for market diesel fuel of 3121 g/kg, measured in 2015, has been applied for 2015 and 2016. After correction for the biofuel content in the samples, this gives 3130 g/kg for fossil diesel fuel. The values between 2004 and 2015 have been interpolated on the basis of market biofuel content.

The resulting heating values and CO<sub>2</sub> EFs for gasoline and diesel are also applied in the emissions calculations for railways (1A3c), domestic waterborne navigation (1A3d), NRMM and fisheries (1A2 & 1A4).

Table 2.2A shows the heating values and CO<sub>2</sub> EFs used for LPG and CNG, which were derived from the Netherlands' list of fuels.

### **N<sub>2</sub>O and CH<sub>4</sub> emissions from road transport**

N<sub>2</sub>O and CH<sub>4</sub> emissions from road transport are dependent not only on the fuel type, but also on the combustion and emission control technology and the operating conditions of the vehicles. Emissions of N<sub>2</sub>O and CH<sub>4</sub> from road transport therefore are calculated using a Tier 3 methodology, based on vehicle kilometres travelled on Dutch territory and technology-specific emission factors, expressed in grams per vehicle kilometre travelled. In this bottom-up approach, vehicle types are distinguished according to:

- Vehicle type, e.g. passenger cars, light-duty trucks, heavy-duty trucks and buses;
- Fuel type, e.g. gasoline, diesel, LPG and natural gas;
- Emission control technology, as a function of the different Euro standards per fuel type for pollutant emissions;
- Operating conditions, using different emission factors for urban driving, rural driving and highway driving and the degree of congestion per road type.

The activity data used for the bottom-up approach is derived from Statistics Netherlands and is described in Chapter 3.3. N<sub>2</sub>O is primarily emitted by petrol and LPG vehicles equipped with three-way catalysts. Most emissions result from the cold start, when the catalyst is not yet warmed-up. The country-specific emissions factors for N<sub>2</sub>O are derived from Kuiper & Hensema (2012). For older vehicle types, emission factors are derived from national emission measurement programmes (Gense and Vermeulen, 2002 & Riemersma et al., 2003). For most modern diesel light duty vehicles, Euro-6, the measurements from the H2020 GVI, and the GreenNCAP program are used to update the N<sub>2</sub>O emission factors (Ruiter and Mensch, 2022). For recent generations of road vehicles with new emission reduction technologies, emission factors are derived from the 2013 EEA Emission Inventory Guidebook. The N<sub>2</sub>O emission factors per vehicle type and road type are shown in Table 3.11.

CH<sub>4</sub> emissions from road transport are derived from total VOC emissions using VOC species profiles. The country-specific VOC emission factors for the different vehicle categories are shown in Table 3.11 and are derived from the VERSIT+ model, as described in Chapter 3.4. The mass fraction of CH<sub>4</sub> in total VOC emissions is dependent on the fuel type, vehicle type and – for petrol vehicles – whether or not the vehicle is equipped with a three-way catalyst. Petrol-fuelled vehicles equipped with a catalyst emit more CH<sub>4</sub> per unit of VOC than vehicles without a catalyst. In absolute terms, however, passenger cars with catalysts emit far less CH<sub>4</sub> than passenger cars without a catalyst because total VOC emissions are far lower. The country-specific VOC species profiles used to derive CH<sub>4</sub> emissions from total VOC emission are shown in Table 3.10.

To make sure CH<sub>4</sub> and N<sub>2</sub>O emissions from road transport are consistent with fuel sales data, the bottom-up approach described above is used to calculate fleet average CH<sub>4</sub> and N<sub>2</sub>O emission factors per unit of fuel used. These emission factors are consequently combined with the fuel sales data from the Energy Balance, as shown in *Table 2.1*, to calculate total CH<sub>4</sub> and N<sub>2</sub>O emissions from road transport. Therefore, N<sub>2</sub>O and CH<sub>4</sub> emissions are consistent with fuel sold.

Emissions resulting from the use of biofuels in road transport are reported separately in the CRF. CO<sub>2</sub> emissions are reported as a memo item and are not part of the national emissions total. CH<sub>4</sub> and N<sub>2</sub>O emissions from biofuels are included in the national emissions total. The emissions calculation for biofuels is comparable to that for fossil fuels and is based on the amount of biofuels delivered to the market. Information on these deliveries is collected by the Netherlands Emissions Authority (NEa) and incorporated in the Energy Statistics by Statistics Netherlands (*Table 2.1*). Emissions of CH<sub>4</sub> and N<sub>2</sub>O from biodiesel and ethanol are calculated using the same EFs as are used for fossil diesel and gasoline, respectively. Emissions measurement programmes use market fuels (Spreeen et al., 2016), including some biofuels. Therefore, the resulting EFs are representative of the market fuels that are used, which include small shares of biofuels. CO<sub>2</sub> emission factors for biofuels are deduced from the composition of biofuels also recorded by NEa. GHG emissions from biofuels in transport are described in paragraph 2.2.8. *Table 2.3* gives an overview of the specific weight, net heating values and (implied) CO<sub>2</sub>, N<sub>2</sub>O and CH<sub>4</sub> emissions factors used for road transport throughout the time-series.

### **CO<sub>2</sub> emissions from lubricants**

CO<sub>2</sub> emissions from the use of lubricants in mopeds and motorcycles are included under source category 1A3biv. There are no data available on the number of two-stroke passenger cars in the Netherlands, but it is expected to be very small. Also, we assume that four-stroke vehicles do not use lubricants. Therefore, only the amount of lubricants used in two-stroke motorcycles and mopeds was estimated. The use of lubricants was estimated assuming that 1 kg of lubricants is used per 50 kg of gasoline (based on expert judgement by TNO). The resulting emissions are calculated with an oxidation factor of 100% and using default CO<sub>2</sub> emission factors.

The remaining amount of lubricants used in transport is calculated as the difference between the total amount of lubricants sold (derived from the Energy Balance) and the estimated amount of lubricants used in two-stroke motorcycles and mopeds.

### **CO<sub>2</sub> emissions from urea-based catalysts**

CO<sub>2</sub> emissions from urea-based catalysts are estimated using a Tier 3 methodology using country-specific CO<sub>2</sub> emission factors for different vehicle types. Selective Catalytic Reduction (SCR) technology has been applied in diesel-fuelled heavy-duty vehicles since 2005 for reduction of NO<sub>x</sub> emissions. To estimate the CO<sub>2</sub> emissions from urea-based catalysts, TNO carried out a study commissioned by the Dutch PRTR to estimate road type specific CO<sub>2</sub> emission factors from the use of urea-additives. The resulting emission factors are shown in *Table 2.4*. The use of urea-additive (AdBlue) was estimated as a percentage of diesel fuel consumption of 6% for Euro V engines and 3% for Euro VI engines. Urea-additive CO<sub>2</sub> emissions were calculated to be 0.6% or less of the diesel fuel CO<sub>2</sub> emissions for Euro V engines and 0.3% or less for Euro VI engines. The methodology used is described in detail in Stelwagen & Ligterink (2014). The AdBlue consumption of modern vehicles has been monitored in recent years. There seems little difference between AdBlue consumption of different Euro classes. A generic 5 liters AdBlue per 100 liter diesel is now used for all diesel vehicles.



The associated CO<sub>2</sub>-emission from AdBlue consumption is 0.262 kg CO<sub>2</sub> per litre AdBlue. This translates into an additional 0.5% extra CO<sub>2</sub>-eq on top of the CO<sub>2</sub> from diesel. Important is the wider application of SCR systems in diesel vehicles, from 2019, i.e., Euro-6d-Temp, SCR systems are common in all diesel passenger cars and light commercial vehicles. The associated NO<sub>x</sub> reduction from AdBlue consumption is 460 gram NO<sub>x</sub> per litre AdBlue, and thus, 23 gram NO<sub>x</sub> reduction per litre diesel.

### 2.2.3 Railways

Fuel sales to railways in the Netherlands are derived from the Energy Balance, as shown in *Table 2.1*. Since 2010, Statistics Netherlands derives fuel sales data from Vivens, a recently founded co-operation of rail transport companies that purchases diesel fuel for the railway sector in the Netherlands. Before 2010, diesel fuel sales to the railway sector were obtained from Dutch Railways (NS). NS used to be responsible for the purchases of diesel fuel for the entire railway sector in the Netherlands.

CO<sub>2</sub> emissions from railways are calculated using a Tier 2 methodology, based on fuel sales data and country-specific heating values and CO<sub>2</sub> emission factors (Swertz et al., 2017), as shown in *Table 2.6 and 2.7*. These heating values and CO<sub>2</sub> emission factors were derived from different measurement campaigns, as described in Section 2.2.2. There are no country specific emissions factors for CH<sub>4</sub> and N<sub>2</sub>O available. As such, CH<sub>4</sub> and N<sub>2</sub>O emissions are calculated using a Tier 1 methodology, employing EFs derived from the 2016 EEA Emission Inventory Guidebook (EEA 2013). The Guidebook provides EFs for N<sub>2</sub>O (24 g/tonne fuel) and CH<sub>4</sub> (182 g/tonne fuel). The resulting EFs per MJ for railways are shown in *Table 2.2B*.

Default EFs from the EEA Guidebook were used instead of using defaults from the 2006 IPCC Guidelines, because the Guidebook is deemed to be the most representative source for CH<sub>4</sub> and N<sub>2</sub>O EFs in the EU. The default EFs for railways included in the 2006 IPCC Guidelines were also derived from the EEA Guidebook, but in this case from an older (2005) version.

Emissions from railways are not a key source in the inventory, so the use of Tier 1 and Tier 2 methodologies is deemed sufficient.

### 2.2.4 Domestic navigation and other sectors: fishing

Diesel fuel consumption for domestic inland navigation is derived from the Energy Balance. Gasoline fuel consumption for recreational craft is not reported separately in the Energy Balance, but is included under road transport. In order to calculate greenhouse gas emissions from gasoline fuel consumption by recreational craft, fuel consumption is estimated using a bottom-up approach as described in NNWB (2008). Gasoline fuel sales data for road transport, as derived from the Energy Balance, are corrected accordingly, as is shown in *Table 2.1*. The CO<sub>2</sub> emissions from waterborne navigation are calculated using a Tier 2 methodology. The same country-specific heating values and CO<sub>2</sub> emission factors for gasoline and diesel are used for waterborne navigation as for road transport, as described in section 2.2.2. These values are derived from Swertz et al. (2017) and presented in *Tables 2.6 and 2.7*.

CH<sub>4</sub> and N<sub>2</sub>O emissions from domestic water-borne navigation are derived using a Tier 1 methodology. Neither the 2006 IPCC Guidelines nor the EEA Emission Inventory Guidebook

provides specific N<sub>2</sub>O and CH<sub>4</sub> emission factors for inland shipping. The Tier 1 default CH<sub>4</sub> and N<sub>2</sub>O emission factors from the 2006 IPCC Guidelines actually apply to diesel engines using heavy fuel oil. Since no emission factors are provided for diesel engines using diesel oil, the emission factors for heavy fuel oil are used in the inventory for diesel oil as well. N<sub>2</sub>O and CH<sub>4</sub> emission factors for gasoline use by recreational craft are not provided in either the Emission Inventory Guidebook or the IPCC Guidelines. Emission factors are therefore derived from gasoline use in non-road mobile machinery, as provided by the 2013 Emission Inventory Guidebook (EEA 2013). The resulting emission factors for N<sub>2</sub>O and CH<sub>4</sub> are shown in *Table 2.2B*.

Fuel deliveries to national fishing are derived from the national Energy Balance, as shown in *Table 2.1*. In line with the 2006 IPCC Guidelines, all emissions from fishing are part of the national emission totals; there is no international bunker fuel category for commercial fishing, regardless of where the fishing occurs. The CO<sub>2</sub> emissions from fisheries are calculated using a Tier 2 methodology. Country-specific heating values and CO<sub>2</sub> emission factors for diesel oil are similar to those for road transport and are derived from Swertz et al. (2017), as shown in *Tables 2.6 and 2.7*. Heating values and CO<sub>2</sub> emission factors for heavy fuel oil are derived from the Netherlands' list of fuels (Zijlema 2023), as shown in *Table 2.2A*. CH<sub>4</sub> and N<sub>2</sub>O emissions from fisheries are derived using a Tier 1 methodology. The emission factors are shown in *Table 2.2B* and are derived from the 2006 IPCC Guidelines.

### 2.2.5 Other sectors: Non-road mobile machinery

Fuel consumption by non-road mobile machinery (NRMM) in different economic sectors is calculated using a modelling approach. The EMMA model (a previous version of which is described in Hulskotte & Verbeek, 2009) uses sales data and survival rates for different types of machinery to estimate the composition of the active fleet. Combined with assumptions on the average use (annual operating hours), the average power output (in kW) and the fuel consumption per unit of work delivered for the different types of machinery, total fuel consumption of NRMM is estimated. The methodology is described more elaborately in Chapter 9.

The results of the EMMA model for both petrol and diesel consumption are used to determine the CO<sub>2</sub> emissions of the NRMM, with the exception of the sale of diesel to NRMM in public services (including container handling and airport GSE). For diesel sale to NRMM in public services the data from the Energy Balance is used. However, the EMMA data does serve as a basis for its determination in the Energy Balance. For the sale of diesel to NRMM in agriculture, the Energy Balance uses data from Cumela (agricultural machinery by contractors) and WecR (agricultural machinery on farms). For construction, the Energy Balance also refers to the energy consumption as calculated by the EMMA model. Those data are therefore equal to each other for the entire time series (the relatively low use of diesel for NRMM in industry creates more uncertainty in the EMMA model, which is why it is not used as a source for these activities in the Energy Balance).

CO<sub>2</sub> emissions and N<sub>2</sub>O emissions from NRMM are estimated using a Tier 2 methodology. Country-specific heating values and CO<sub>2</sub> emission factors are used similar to those for road transport, as described in section 2.2.2. CH<sub>4</sub> emissions from NRMM are estimated using a Tier 3 methodology, using country specific emission factors derived from EMMA. The methodology takes into account the fleet composition and the impact of EU emissions legislation for VOC emissions from non-road engines. CH<sub>4</sub> emissions are calculated as fractions of total VOC emissions using VOC species profiles (similar to road transport, using the fractions from *Table 3.10A*). The resulting CH<sub>4</sub> emission factors are presented in *Table 9.6*.

## 2.2.6 Other sectors: Military use

The fuel deliveries for military aviation and navigation are derived from the Energy Balance. This includes all fuel delivered for military aviation and navigation purposes within the Netherlands, including fuel deliveries to militaries of external countries. The fuel deliveries for the entire time series are shown in *Table 2.1*. The emission factors used for calculating greenhouse gas emissions resulting from military aviation and water-borne navigation are presented in *Table 2.2A and 2.2B*. The CO<sub>2</sub> emission factors are derived from the Ministry of Defence, whereas the emission factors for N<sub>2</sub>O and CH<sub>4</sub> are derived from Hulskotte (2004).

## 2.2.7 Memo items: International bunkers

The deliveries of bunker fuels for international aviation and waterborne navigation are derived from the Energy Balance. CO<sub>2</sub> emissions from bunker fuels are calculated using a Tier 1 and Tier 2 approach. Default heating values and CO<sub>2</sub> emission factors are used for heavy fuel oil and jet kerosene, whereas country-specific heating values and CO<sub>2</sub> emission factors are used for diesel oil, as shown in *Table 2.2* and described in Netherlands' list of fuels (Zijlema 2023). CH<sub>4</sub> and N<sub>2</sub>O emissions resulting from the use of bunker fuels are calculated using a Tier 1 approach, using default emissions factors for both substances.

## 2.2.8 Fossil carbon in biofuels

Part of the carbon in certain types of biofuels has a fossil origin and as such should be reported as fossil fuel. The methodology used for the calculation of resulting GHG emissions is as follows:

1. Deriving the total amount of biogasoline and biodiesel used for transport in the Netherlands from the Energy Balance, as reported annually by Statistics Netherlands.
2. Determining the share of different types of biogasoline and biodiesel used in the Dutch market, as reported annually by the Dutch Emission Authority (NEa, 2021).
3. Applying the fossil fraction of the carbon content per type of biofuel as provided by (Sempos, 2018).

Table 2.8 shows the input for steps 2 and 3, i.e. the shares of different types of biofuels in total biogasoline and biodiesel use for transport in the 2011-2021 period, as reported by NEa (2021), and the fossil part of the carbon content per fuel type.

For biogasoline, no adjustments were made to the activity data from the Energy Balance as Statistics Netherlands already takes into account that part of bio-ETBE and bio-MTBE has a fossil origin and adjusts its data accordingly. Thus, the shares of bio-ETBE and bio-MTBE with a fossil origin are reported as gasoline, not as ethanol in the Energy Balance. The fossil fractions used by Statistics Netherlands were derived from Annex III of the EU Renewable Energy Directive (2009/28/EC). These fractions, as shown in Table 2.8, differ slightly from those provided by Sempos (2018). Sempos assumes a fossil fraction of 66.7% for bio-ETBE (compared to 63% according to the RED) and 80.0% for bio-MTBE (compared to 78% according to the RED). Given the small difference between both sources and the small share of bio-ETBE and bio-MTBE in total use of biogasoline for transport in the Netherlands (as shown in Table 2.8), no adjustments were made in the activity data for biogasoline as derived from the Energy Balance.

Biodiesel for transport in the Netherlands mostly consists of FAME. For the 2003-2010 period, all biodiesel used for transport was assumed to be FAME. To determine the fossil part of FAME, the default value of 5.4% as provided by Sempos (2018) was applied. The activity data from the Energy

Balance were adjusted accordingly. As such, 5.4% of FAME is assumed to be of fossil origin. This is reported separately in the CRF under 'Other fossil fuels' for source categories 1A3b, 1A3c, 1A4aii and 1A4cii, as biodiesel is used in road transport, rail transport and non-road mobile machinery. For source category 1A2gvii the CRF does not include 'Other Fossil Fuels'. As such, the activity data and GHG emissions from the fossil part of biodiesel was included under liquid fuels for this source category.

## 2.3 Uncertainties and time series consistency

The uncertainty estimates for the activity data and emission factors used for the different source categories described above are shown in *Table 2.5*. The sources for the uncertainty estimates are also shown in *Table 2.5*. The uncertainty estimates for the activity data are for the most part derived from the experts from Statistics Netherlands who are responsible for compiling the Energy Balance. For most activity data the uncertainty is deemed rather small. Uncertainty in CO<sub>2</sub> emission factors is based on expert judgement, as described in the National Inventory Report. For CH<sub>4</sub> and N<sub>2</sub>O emission factors, the uncertainty estimates for the most part are derived from the 2006 IPCC Guidelines. In general, the uncertainty in CO<sub>2</sub> emissions is deemed rather small, whereas uncertainty in N<sub>2</sub>O and CH<sub>4</sub> emissions is large. It should be noted that the share of N<sub>2</sub>O and CH<sub>4</sub> in total greenhouse gas emissions from transport (in CO<sub>2</sub> equivalents) is very small.

Uncertainty estimates for activity data of civil aviation, road transport, railways and domestic waterborne navigation are derived from Statistics Netherlands. The uncertainty estimates for emission factors are taken from the 2006 IPCC Guidelines if default factors are applied. The uncertainties in emission factors for road transport and CO<sub>2</sub> emission factors for other source categories are based on expert judgement, which were determined in workshops. The uncertainty in total VOC emissions from road transport was estimated by Broeke and Hulskotte (2009).

## 3 Road transport

### 3.1 Source category description

Road transport includes all motorized vehicles that are licensed and which travel on public roads. Road transport comprises, among other things, passenger cars, light-duty trucks, lorries, road tractors, buses, special purpose vehicles (such as fire trucks and garbage trucks) and powered two-wheelers such as motorcycles and mopeds. Except for a small (but increasing) number of electric vehicles, road vehicles are equipped with a combustion engine for propulsion. In such engines, the chemical energy of fuels such as petrol, diesel and LPG is converted into mechanical energy. During this conversion process, various substances are emitted via the exhaust gas. In addition, emissions are released by the evaporation of motor fuels and coolants, the wear of brakes, tyres and the road surface, and the leakage and consumption of motor oil. Depending on the emission process, a specific calculation method is used. This is described in more detail in Section 3.2.

The emissions of air pollutants by road transport are reported under source category 'Road Transport' (1A3b) in the NFR. This source category comprises all emissions from road transport, including emissions from passenger cars (1A3bi), light-duty trucks (1A3bii), heavy-duty vehicles and buses (1A3biii) and mopeds and motorcycles (1A3biv). It also includes evaporative emissions from road vehicles (1A3bv) and PM emissions from tyre and brake wear (1A3bvi) and road abrasion (1A3bvii). PM emissions caused by resuspension of previously deposited material are not included in this source category.

The UNECE Guidelines for reporting air pollutant emissions under the LRTAP convention (UNECE 2014) prescribe that emissions from road vehicle transport should be consistent with the national energy balance and therefore should 'be calculated on the basis of the fuel sold in the Party concerned'. In order to derive air pollutant emissions on the basis of *fuel sold* in the Netherlands, emissions are first calculated 'bottom-up' using data on vehicle kilometres driven and specific emission factors per vehicle kilometre (i.e. on a *fuel used* basis). The resulting emissions on Dutch public roads are used annually for air quality modelling. For international reporting, the emissions are subsequently adjusted to correct for differences between fuel used and fuel sold in the Netherlands. This is described in detail below.

### 3.2 Emissions processes and calculation methods

Emissions from road transport originate from different processes, including exhaust emissions due to combustion of motor fuels in internal combustion engines of road vehicles, evaporation of motor fuels, and wear of tyres, roads and brakes. Different methodologies are used for these processes, as described below. This section only describes the methodologies used, the actual activity data and emission factors used in these methodologies are described in Section 3.3. Spreen et al. (2016) provides a detailed overview of the methodology for assessment of road vehicle emissions in the Netherlands.

### 3.2.1 Technology dependent exhaust emissions

The exhaust emissions of carbon monoxide (CO), volatile organic compounds (VOC), nitrogen oxides (NO<sub>x</sub>), ammonia (NH<sub>3</sub>) and particulate matter (PM<sub>10</sub>) depend on the type of fuel, the engine and exhaust gas after treatment technology, driving speed and driving behaviour. These emissions are calculated by multiplying the vehicle kilometres travelled on Dutch territory per vehicle type by emission factors per vehicle type, road type and congestion level, expressed in grams per vehicle kilometre. The emission factors are derived annually from measurements under test conditions, representing real-world use, and from real-world driving.

For the 1990-2017 time period exhaust emissions of CO, VOC, NO<sub>x</sub>, NH<sub>3</sub>, and PM<sub>10</sub> from road transport were calculated according to the methodology as described in Klein et al (2019). The methodology was based on a calculation using average mileages per vehicle class. A representation of the vehicle kilometres and emission factors used for these calculations are shown in *Table 3.15*.

#### **Bottom-up methodology**

In 2019 a new methodology was first deployed which calculates emissions for each individual vehicle in the Dutch car fleet using a bottom-up method which takes annual mileages per vehicle (based on odometer readings) as a starting point. This methodology is based on determining emissions bottom-up, on the level of license plates (per vehicle), and is applied for emissions of NO<sub>x</sub>, NMVOC, NH<sub>3</sub>, CO, CO<sub>2</sub>, N<sub>2</sub>O, CH<sub>4</sub> and EC and combustion and wear emissions of PM. This methodology was used to (re)calculate emissions for 2012, 2015 and 2018 and subsequent years. The emissions for the years 2005 till 2017 (excluding 2012 and 2015) were recalculated in order to establish a consistent timeseries. To this end, the road type distribution and emission factors of the vehicle categories underlying the emission calculations were linearly interpolated between 2004 (methodology from Klein et al.) and 2012 (bottom-up methodology) and between 2012 and 2015 (bottom-up methodology).

The calculation uses emission factors (grams per vehicle kilometre) per vehicle class per road type. In order to calculate emissions, each vehicle is assigned to one of the 350+ VERSIT vehicle classes. The vehicle classes are defined by: vehicle type (passenger cars, light-duty trucks, etc.), weight class, fuel type, emission legislation class (Euro standards) and, for specific vehicle types, the engine and exhaust gas technology used to comply with the specific Euro standard (e.g. the use of Exhaust Gas Recirculation (EGR) or Selective Catalytic Reduction (SCR) to comply with Euro V emissions standards for heavy-duty engines).

Additionally, a distinction in emission factors is made between three road types. This includes travelling within the urban area (RT<sub>1</sub>), on rural roads (the roads outside the urban area with a typical speed limit of 80 km/hour; RT<sub>2</sub>) and on motorways (RT<sub>3</sub>). The distinction between road types is necessary because emissions per vehicle kilometre can differ significantly as a result of differences in maximum speed and driving dynamics (degree of acceleration, deceleration, constant driving and idling). In addition, cold starts, which are characterized by relatively high emissions, mostly take place in urban areas and in rural areas. The emission factors are derived annually from measurements under test conditions, representing real-world use, and from real-world driving. Emission factors are measured for each vehicle class. By using the highest odometer reading, aging of vehicles was also taking into account in calculating the emissions of VOS, CO, CH<sub>4</sub>, NMVOC and NO<sub>x</sub>.

Road type distributions of vehicle kilometres concerning the three road types are calculated in two

separate steps. Firstly, an estimate of road type distributions per vehicle is based on the annual mileage of individual vehicles (per unique licence plate number). The annual mileages are derived from the odometer registration database of the Netherlands Vehicle Authority (RDW). The distribution per road type is not available in this data, and is therefore estimated using formulas derived by TNO from licence plate registrations. Depending on the vehicle type, different methods are used to determine the road type distribution of kilometres. In general for passenger cars, the higher the annual mileage, the higher the share on motorways, whereas low annual mileages correspond to a higher share of urban driving. For light-duty and heavy-duty vehicles (except buses) the built year is leading. For delivery vans for example, the older the vehicle, the fewer the share of kilometres driven on motorways. In the second step, we fit the total distribution of vehicle kilometres for the three road types per vehicle type to the overall distribution from Klein et al. (2019), which was the distribution used for emission calculations of transport in previous years. The road type distributions for different vehicle types are derived from Goudappel Coffeng (2010) and are described further in Chapter 3.3. Finally, emission totals per pollutant for each individual vehicle are calculated by multiplying the emission factors with the annual vehicle kilometres per road type. The emissions are aggregated to vehicle types for reporting purposes.

Using this methodology, we can now calculate emissions per vehicle class much more precisely. Up until 2018, annual mileages were derived only at an aggregated level, e.g. for all petrol cars older than 10 years. Within this group there are large differences though in the emissions per vehicle kilometre. For some substances, e.g. PM, older vehicles have a large share in emissions totals because of the very low emissions of modern vehicles equipped with diesel particulate filters. Figure 3.1 shows the different steps for calculating the exhaust emissions of CO, VOC, NO<sub>x</sub>, NH<sub>3</sub>, and PM from road transport.

**Figure 3.1**

Methodology for calculating emissions of CO, VOC, NO<sub>x</sub>, N<sub>2</sub>O, NH<sub>3</sub>, and PM<sub>10</sub> due to combustion of motor fuels

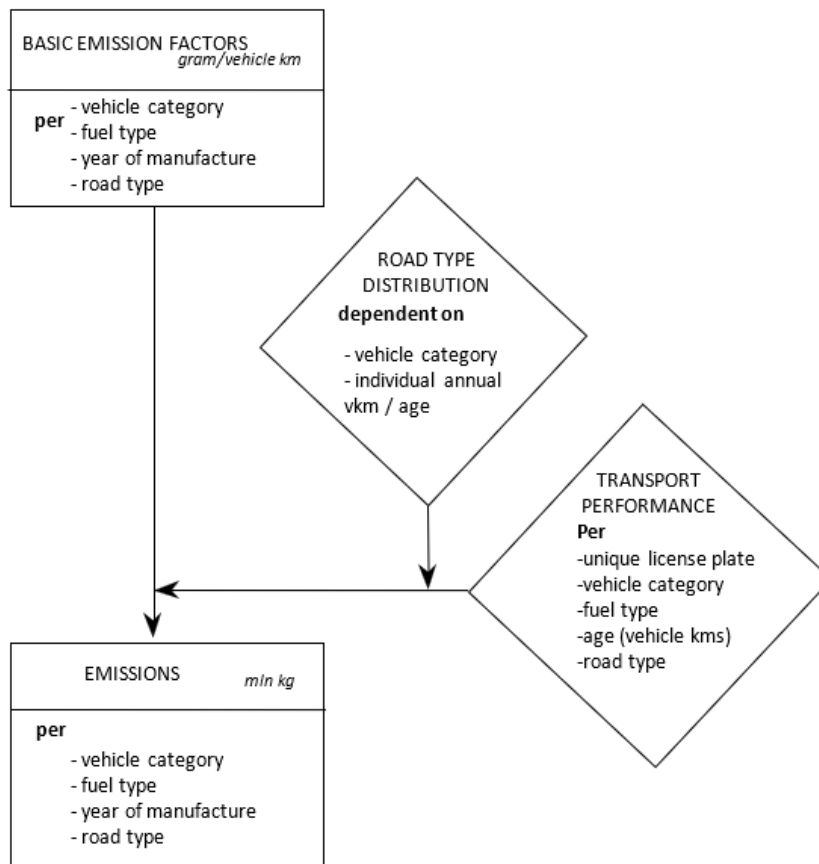

### 3.2.2 Fuel dependent exhaust emissions

Figure 3.2 shows the calculation method used for the exhaust emissions of SO<sub>2</sub> and heavy metals by road transport. These emissions are directly related to the fuel consumption of vehicles and the type of fuel used. Fuel comprises sulphur, the internal combustion may change the chemical composition but the input of organically bound sulphur (in the fuel) is equal to the output of SO<sub>2</sub> (exhaust gas). The fuel consumption (the diamond in Figure 3.2) is derived by multiplying fuel consumption factors with the number of kilometres travelled by different types of vehicles in the Netherlands. The emission calculation involves multiplying emission factors (gram/litre of fuel) with the fuel consumption per vehicle category, fuel type and road type. Fuel consumption (litre/kilometre) figures were derived by TNO using insights from emission measurements and fuel-card data (Ligterink et al., 2016, Van Gijlswijk et al. 2021).



**Figure 3.2**

Methodology for calculating emissions of SO<sub>2</sub> and heavy metals (cadmium, copper, chrome, nickel, zinc, lead, vanadium) due to combustion of motor fuels

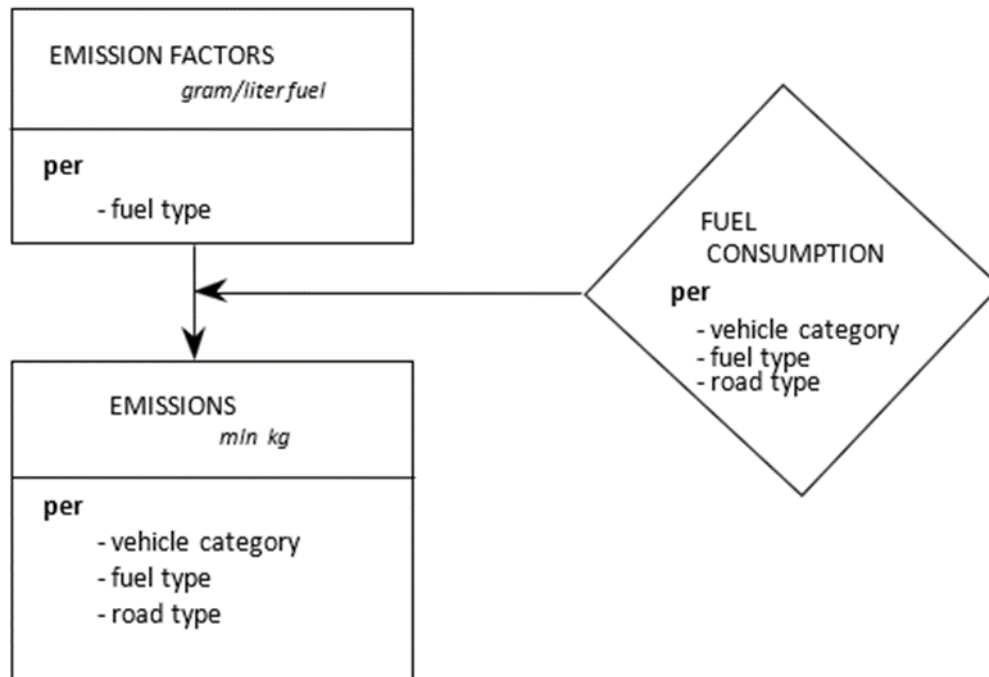

### 3.2.3 Exhaust emissions of VOC and PAH species

The calculation of the exhaust emissions of approximately 70 different VOC species, including methane and PAHs, uses species profiles, as is shown in Figure 3.3. For each fuel type, a VOC species profile is used that indicates the fractions of the various VOC components in total VOC emission (Tables 3.10A-E). Different VOC species profiles are used for petrol-fuelled vehicles with and without a catalyst, because the catalyst oxidizes certain VOC components more effectively than others. The VOC and PAH profiles for each fuel type were obtained from a literature study (VROM 1993). For diesel powered vehicles from year of construction 2000 and later and petrol fuelled vehicles equipped with a 3-way catalytic converter, the profiles were derived from Ten Broeke & Hulskotte (2009).

**Figure 3.3**  
Methodology for calculating emissions of VOC and PAH components caused by combustion of motor fuels

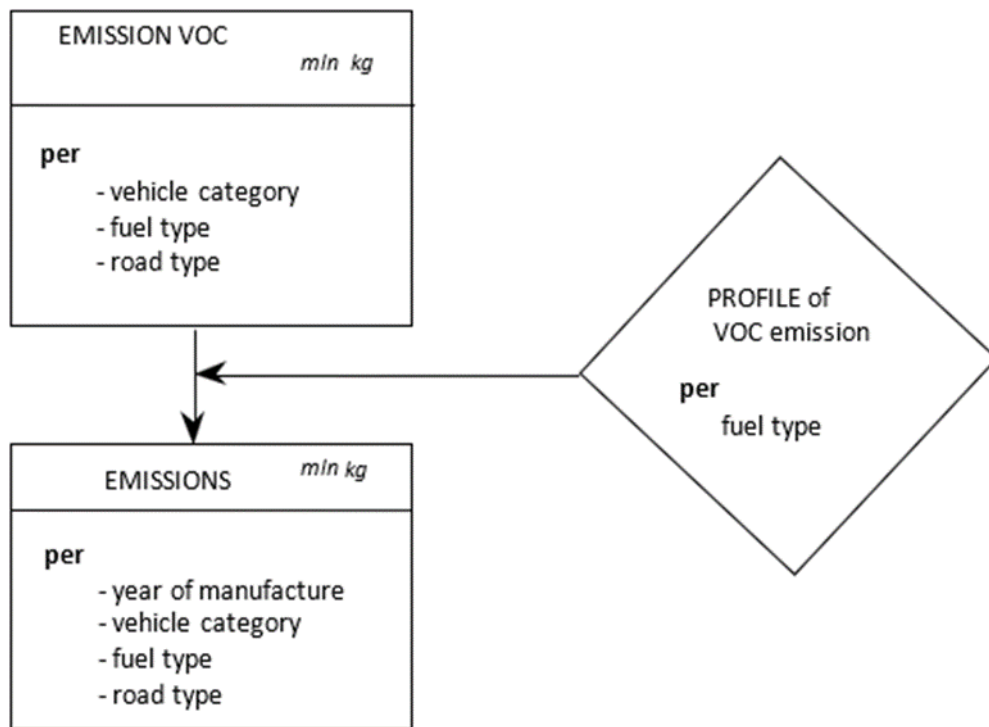

### 3.2.4 Evaporative emissions of VOC and VOC components

Petrol evaporates to some extent from vehicles when they are parked, when they cool off after being used and while they are being used. The resulting evaporative emissions are calculated according to the methodology described in the European Emission Inventory Guidebook (EEA 2007). This methodology distinguishes three mechanisms which are primarily responsible for the evaporative emissions from petrol driven vehicles (in case of LPG, diurnal emissions only):

#### 1. Diurnal emissions

Diurnal emissions are caused by the daily variation in the outdoor temperature. A rise in temperature will cause an increase of the amount of petrol vapour in the fuel system (i.e. the tank, fuel pipes and fuel injection system). Part of this vapour is emitted (together with air) from the canister system to prevent overpressure (tank breathing). Diurnal emissions mainly originate from the fuel tank and are independent of vehicle use. The diurnal emissions are expressed in grams per vehicle per day.

#### 2. Running losses

The running losses occur while driving. The heat of the engine leads to the fuel heating up in the fuel system and thereby to evaporation of part of the fuel. In modern cars the use of the car has no influence on the fuel temperature in the tank. As such the running losses (and also hot and warm soak emissions) of these cars are very low. Running losses are expressed in grams per vehicle kilometre travelled.

### 3. Hot and warm soak emissions

Hot and warm soak evaporative emissions are caused by the engine heat and occur when a warmed up engine is turned off. The difference between hot soak and warm soak emissions is related to the engine temperature: hot soak occurs when the engine is completely warmed up. The evaporation of petrol is smaller when the engine is not yet entirely warmed up. Hot and warm soak emissions are expressed in grams per vehicle per stop.

The amount of petrol vapour released from these three mechanisms strongly depends on (variation in) outdoor temperatures, the fuel volatility and the type of fuel injection. Furthermore, running losses depend on vehicle use. Due to the application of carbon canisters in new cars since the early nineties, the evaporative losses of road transport have been reduced strongly. These canisters adsorb the majority of the evaporated petrol, which is led back into the engine. Figure 3.4 shows the emission calculation process for evaporative emissions. The Emission Inventory Guidebook includes a generic set of emission factors for each of the mechanisms mentioned above. Within these sets a distinction is made between the canister type, cylinder capacity, and average outdoor temperatures. Each set contains separate emission factors for cars with a carburettor and cars with fuel injection. Based on these factors a set of basic emission factors has been developed for Dutch circumstances (see *Table 3.2*), based on data on the composition and vehicle kilometres travelled of the Dutch car fleet. It was assumed that the introduction of canisters and fuel injection took place simultaneously with the introduction of three-way catalytic converters.

The average outdoor temperatures in the Netherlands have been determined on the basis of data from the Dutch Meteorological Institute (KNMI) during 1990-2006. The basic emission factors have been converted into emission factors per vehicle per day for the Dutch situation (see *Table 3.2*). Finally it is assumed that 90% of the emissions take place in urban areas. The evaporative emissions of motor cycles and mopeds are likewise calculated using emission factors from the Emission Inventory Guidebook 2007. Petrol vapour released during tanking is attributed to the fuel circuit (filling stations) and not to vehicle use. Due to the low volatility of diesel fuel the evaporative emissions of diesel powered vehicles have been assumed negligible.

**Figure 3.4**  
Methodology for calculating emissions of VOC components caused by evaporation of motor fuels

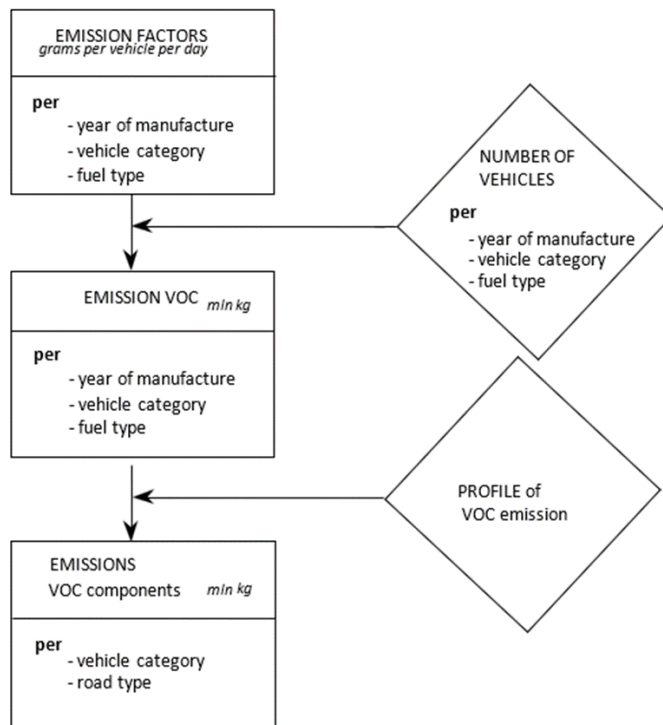

### 3.2.5 PM emissions resulting from wear of tyres, brakes and road surfaces

Wear of tyres, brakes and road surfaces result in particle emissions, some of which is PM<sub>10</sub> and PM<sub>2.5</sub>. Figure 3.5 gives an overview of the calculation methodology for wear emissions.

#### **Tyre wear of road vehicles**

Vehicle tyres experience wear due to the friction between the tyres and the road. This results in emissions of particulate matter (PM). The PM-emissions resulting from tyre wear are calculated by multiplying vehicle kilometres travelled with emission factors (expressed in milligrams of tyre particulate matter emission per kilometre). The emission factors are calculated as the total mass loss of tyres resulting from the wear process and the number of tyres per vehicle category. The emission factors for each individual vehicle are corrected bottom-up for the relative mass and power of the vehicle, compared to the average mass and power of the vehicle category:

$$\text{Wear}_{\text{veh}} = \text{wear}_{\text{cat}} * \left( \frac{3}{4} * \frac{\text{mass}_{\text{veh}}}{\text{mass}_{\text{cat\_avg}}} + \frac{1}{4} * \frac{\text{power}_{\text{veh}}}{\text{power}_{\text{cat\_avg}}} \right)$$

The emission factors used are shown in Table 3.3A. The emission factors were derived from literature study (Ten Broeke et al., 2008). The differentiation of the emission factors per road type was estimated using the forces (acceleration, driving resistance, and braking) on the wheels of the vehicles as a proxy (Velders et al., 2009). It was assumed that 5% of the tyre PM-emissions consists of PM<sub>10</sub>, the remainder being larger fractions that do not stay airborne but are emitted to the soil or surface water. The PM<sub>2.5</sub>/PM<sub>10</sub> ratio is estimated to be 20% (see Table 3.13). Both fractions were derived from Ten Broeke et al. (2009) and are highly uncertain. Recent research suggests that the fraction of PM<sub>10</sub> in tyre emissions is smaller than 10%. (H2020 Leon T project, 2022).

The emissions of heavy metals due to tyre wear are calculated by applying the heavy metal composition profile of tyre material. This composition is shown in *Table 3.6B*. The emission factors were derived from literature study (Duijnhoven et al., 2021). It is assumed that the amount of heavy metals incorporated in PM<sub>10</sub> is emitted to the air because PM<sub>10</sub> particles remain airborne. The amount of heavy metals incorporated in the coarse particle fraction (>PM<sub>10</sub>) deposits on the soil or the surface water. Within urban areas, it is assumed that 60% of the coarse particle fraction ends up in surface water (*Table 3.3B*) which in this case means in the sewers, while 40% ends up in the soil. Outside urban areas, it is assumed that 10% ends up in surface water and 90% in soil.

**Figure 3.5**  
Methodology for calculating emissions of particulate matter caused by wear of tires, brake linings and road surfaces

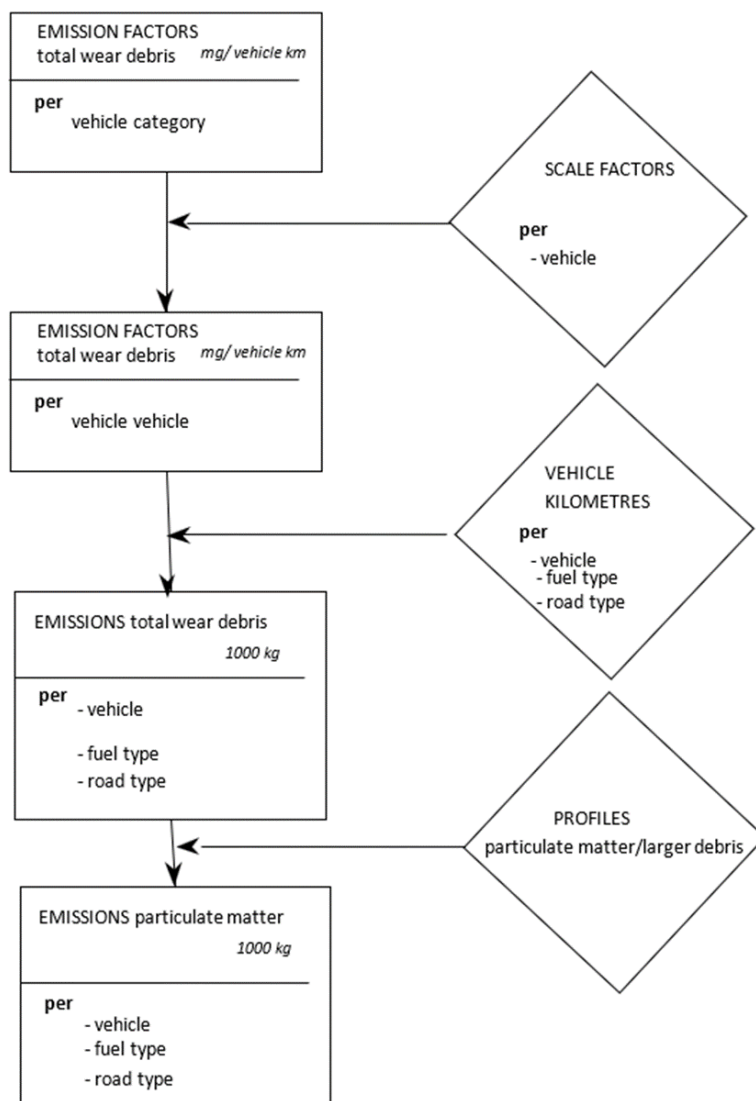

### ***Wear of brake linings of road vehicles***

Similar to the wear of tyres, emissions from wear of brake linings are also calculated using emission factors per vehicle kilometre travelled. The emission factors are shown in *Table 3.3A*. Full electric

vehicles are assumed to have no emissions from brake linings, although limited mechanical braking occurs. The emission factors for each individual vehicle are corrected bottom-up for the relative mass and power of the vehicle, with the formula displayed at the tyre wear section. These emission factors were also derived from literature study (RWS, 2008, Barlow et al. 2007, Boulter et al. 2006). The differentiation of the emission factors per road type was estimated using the braking forces on the wheels of the vehicles as a proxy (Velders et al., 2009). It is assumed that the material emitted from brake linings comprises of 49% particulate matter (PM<sub>10</sub>) and 20% larger fragments. The remainder of the material (31%) remains on the vehicle. The PM<sub>2.5</sub>/PM<sub>10</sub> ratio is estimated at 15% (see Table 3.13). Again, these estimates are highly uncertain due to a lack of empirical data. The emissions of heavy metals caused by the wear of brake linings are calculated by applying a profile of the composition of brake lining material (Table 3.6B), derived from RWS (2008). For the allocation of the emissions of heavy metals to soil and water as a result of brake lining wear, the same percentages are used as with tyre wear emissions (3.6B).

### ***Wear of road surface caused by road vehicles***

The PM emissions of wear of road surface are calculated in the same manner as the emissions of tyre and brake lining particulate matter. It is assumed that the PM-emission of road surface wear caused by a vehicle is 1.6 times higher than the PM emission from tyre wear. The emission factors are shown in Table 3.3A and were based on literature study (Denier van der Gon et al., 2008). The emission factors for each individual vehicle are corrected bottom-up for the relative mass and power of the vehicle, with the formula displayed at the tyre wear section. The differentiation of the emission factors per road type was estimated using the total lateral forces on the wheels of the vehicles as a proxy (Velders et al., 2009). It is assumed that the road surface wear PM emission comprises of 5% PM<sub>10</sub>, the remainder being larger fragments.

PM<sub>2.5</sub> emission factors are derived from PM<sub>10</sub>, using ratios of 15% (brake wear and road abrasion) and 20% (tyre wear), respectively. It should be noted that PM<sub>10</sub> emission factors for tyre and brake wear and for road abrasion, and specifically the PM<sub>2.5</sub>/PM<sub>10</sub> ratios, are highly uncertain due to a lack of data (Table 3.13). The emissions of heavy metals from road surface wear were calculated in the past by using a profile of the composition of such fragments. Denier van der Gon et al. (2008) showed that hardly any heavy metals are released from road surfaces, so heavy metal emissions from road surface wear are no longer calculated.

### ***PAH and heavy metals emissions caused by wear of tyres, brake linings and road surfaces***

PAH emission factors for wear of tyres are based on Duijnhoven et al. (2016). In this study an estimate was made of the decreasing emissions from tyre wear as a result of EU-directive EG 76/769 (EU, 2005) concerning the ban on tyres containing aromatic oils in concentrations exceeding 1 mg/kg of Benzo(a)pyrene or more than 10 mg/kg of EU-PAK compounds. It is predicted that by 2015 and beyond a reduction of 90% in PAKs is achieved as shown in Table 3.6C. In a later study by from Duijnhoven et al. (2021), the fractions of the PAH-components resulting from wear of tyres were updated and provided for different time periods as shown in Table 3.6D.

**Figure 3.6**  
Methodology for calculating emissions of PAH components and heavy metals caused by wear of tyres, brake linings and road surfaces

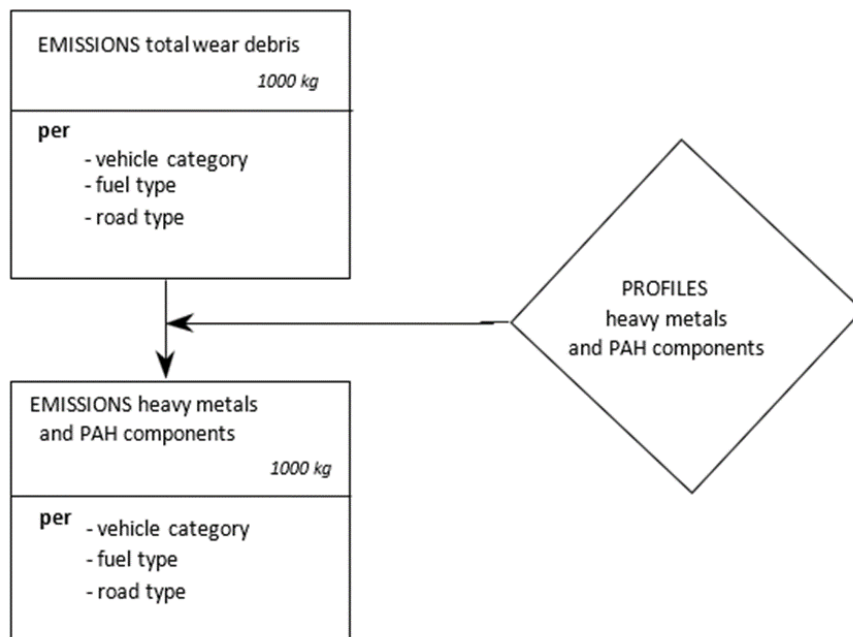

PAH emission factors for road surface wear were derived from Denier van der Gon et al. (2008). This study shows that in 1990 85% of the binders used in rural road and motorway surfaces were tar-based (TAG). After 1991 TAG was replaced by asphalt with bituminous binding agents, resulting in a major decrease of PAH-content of road surfaces. The PAH emissions from road surfaces constructed after 1990 are considered negligible. As such, PAH emissions only occur from roads with a surface before 1991. Due to the gradual replacement of asphalt the old TAG is disappearing. It is estimated that in 2000 24% of the motorways and 51% of the rural roads contain TAG-asphalt. In 2004 this is reduced to 0% of the motorways and 27% of the rural roads. On roads in urban areas a major part of the road network consists of non-asphalt roads. It is assumed that in 2015 asphalt applied before 1991 on roads in built-up areas, has been replaced. The phase-out of PAH-containing asphalt is shown in Table 3.8B.

### **Effects of open graded asphalt mixes**

On motorways on which open graded asphalt mixes (called ZOAB in the Netherlands) are used, the coarse particles that are deposited onto the road surface are partially trapped and are not washed to the soil or surface water. Because open graded asphalt mixes are periodically cleaned (approximately twice per year), these "trapped" coarse particles (containing heavy metals) are removed from the environment. Based on a memorandum from Centre for Water Management (Van den Roovaart, 2000) it was estimated that the emission of heavy metals to the soil and the water for open graded asphalt mixes is between 11 and 40 times lower than for closed graded asphalt mixes (see Table 3.8A). For PAHs, this is a factor of 2.5. In the meantime, a large percentage of the motorways have been provided with a top layer of open graded asphalt mixes (Table 3.8A). The table also shows the factors for heavy metals and PAHs with which the total quantities of

heavy metals and PAHs that are deposited on open graded asphalt mixes must be multiplied to calculate the heavy metals and PAHs that are washed off the road surface.

### Allocation to soil and surface water

The emission factors of tyre wear, brake lining wear and road surface wear, expressed in mg per vehicle kilometre, are shown in Table 3.3A. The profiles with respect to the allocation to water and soil (and air) are shown in Table 3.3B.

### 3.2.6 Leakage of lubricant oil; heavy metals and PAHs

The average oil leakage per vehicle kilometre travelled has been calculated in the past, derived from the total oil leakage in that year and the total number of vehicle kilometres. This calculation is based on measurements on roads that were interpreted by Feenstra and Van der Most (1985) and resulted in an average leakage loss of 10 mg per vehicle kilometre. The leakage losses for the various vehicle categories in road transport are calculated based on a set of factors, of which an example is given in Table 3.4. These factors are based on a number of assumptions that are listed in Table 3.5. One of the assumptions is that older vehicles have more leakage than younger vehicles (see also Figure 3.7).

**Figure 3.7**

Methodology for calculating emissions of PAH components and heavy metals and PAHs due to leakage of lubricant oil from vehicles

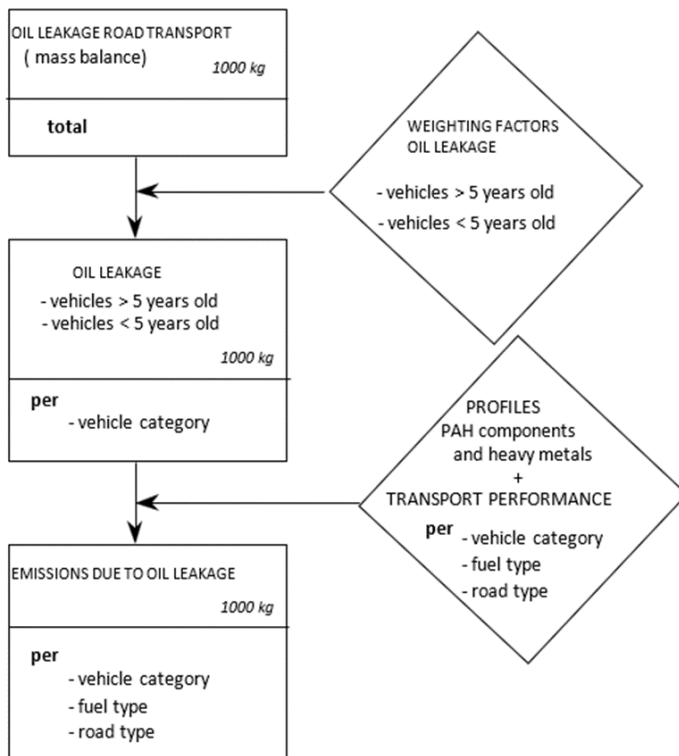

### 3.2.7 Consumption of lubricant oil; heavy metals

Oil consumption can be estimated with the vehicle kilometres and consumption factors for lubricant oil (Figure 3.8). It is assumed that the oil consumption of motor vehicles is 0.2 litre per



1000 km. For motorcycles and mopeds the consumption is assumed to be 0.1 and 0.67 litre per 1000 km respectively. Lubricant oil leaks via the piston rings into the combustion chamber of the engine, where it is burnt. Because this concerns a combustion emission, it is assumed that the emissions of other substances have already been registered via the exhaust gas emissions. The heavy metals are an exception. These are considered to be extra emissions and therefore are calculated separately by multiplying the consumption of lubricant oil and the lubricant oil profile (see Table 3.9B).

**Figure 3.8**  
Methodology for calculating emissions of heavy metals due to combustion of lubricant oil

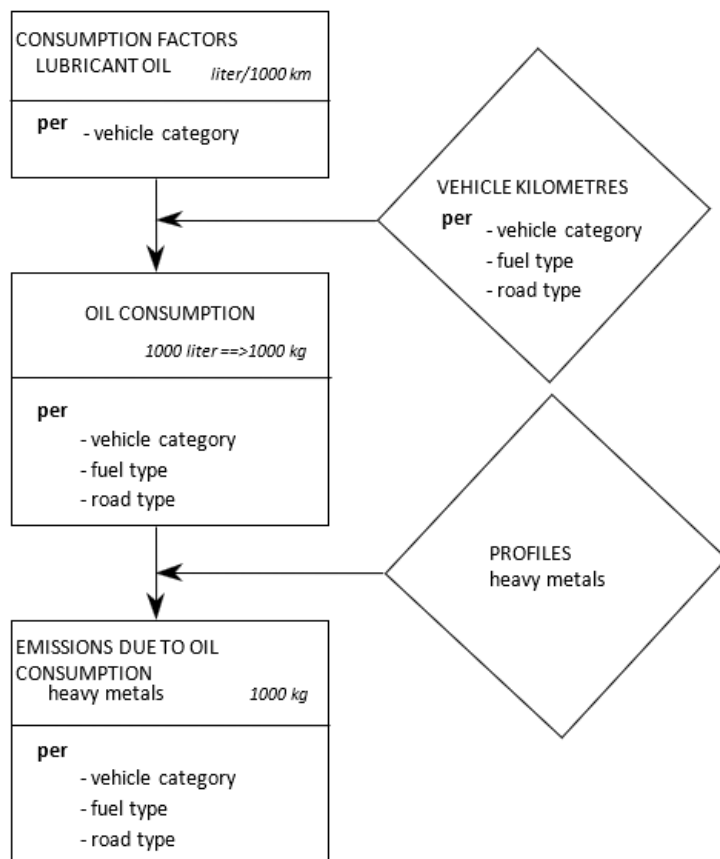

### 3.2.8 Refrigeration units on trucks

Part of the heavy duty truck and semitrailer fleet is equipped with refrigeration units. These units have their own engine and exhaust system. Since emissions are hardly regulated by EU emission legislation, under NRMM, emissions are rather high. In order to calculate the emissions from refrigeration units, measurements were performed on two units in everyday use during several months in 2019 and 2020 (Vermeulen et al. 2021). From each measurement campaign average use per day and average emissions per day were estimated. The number of trucks and semi-trailers with refrigeration units in use in the Netherlands was derived by Statistics Netherlands from vehicle fleet data. The semi-trailers were assumed not to be used full time, but 1500 hours per year, while refrigeration units on trucks were assumed to operate 2000 hours per years. This is more than the number of operation hours of the truck itself, because, while parked the unit remains running. In order to derive a consistent time series, the following approach was used:

- Both the truck and trailer that were used for the measurements were relatively new. To take into account that older vehicles tend to have lower annual mileages than newer vehicles, a usage trend (average number of hours in use per day) was estimated on the basis of the average annual mileages for trucks and tractor-trailers of different age classes using data from Statistics Netherlands.
- Emission factors per hour of use as derived from the measurements were applied to the entire time series since emissions from refrigeration units are not regulated, .i.e., no increasing stringency in the requirements.
- The number of trucks and trailers with a refrigeration unit could be derived from vehicle statistics only for recent years. The remainder of the time series was estimated on the basis of the total number of trucks and trailers in use in the Netherlands, as reported by Statistics Netherlands.

### 3.2.9 Fuel sold emissions from road transport

Historically, the emissions of NO<sub>x</sub>, PM, NMVOC, CO and NH<sub>3</sub> from road transport in the Netherlands have been calculated and reported based on the number of vehicle kilometres driven per vehicle type. The resulting emission totals are referred to as *fuel used* (FU) emissions, since they correspond to the amount of fuel used by road transport on Dutch territory. The UNECE guidelines on reporting emission data under the LRTAP convention state that emissions from transport should be consistent with national energy balances as reported to Eurostat and the International Energy Agency (IEA). As such, emissions from road transport should be estimated based on *fuel sold* (FS) to road transport on national territory. In addition, emissions from road transport may also be reported based on fuel used or kilometres driven on national territory (UNECE 2014).

To derive fuel sold (FS) emissions from road transport, the fuel used (FU) emissions per fuel type are adjusted for differences between (estimated) fuel used by road transport in the Netherlands and fuel sold as reported by Statistics Netherlands. The methodologies used to estimate fuel consumption by road transport in the Netherlands are described in Section 3.4.2. Fuel sales to road transport are reported in the national Energy Balance and are adjusted for use of fuel in different applications, as described in Section 2.2.2 and shown in *Table 2.1*. The fuel sales are divided to the different vehicle categories. Dividing fuel used emission totals per vehicle category by the total amount of fuel used results in average emission factors per unit of fuel used (kg/MJ). These emission factors are consequently multiplied by the fuel sales data from the Energy Balance to calculate total CH<sub>4</sub> and N<sub>2</sub>O emissions from road transport.

## 3.3 Activity data for road transport

Data on the number of vehicle kilometres travelled in the Netherlands by different vehicle types are derived annually from Statistics Netherlands. Statistics Netherlands calculates total vehicle mileages using data on:

1. The size and composition of the Dutch vehicle fleet;
2. Average annual mileages for different vehicle types, and
3. The kilometres driven by foreign vehicles in the Netherlands.

Data on the size and composition of the Dutch vehicle fleet (1) are derived from RDW (the Netherlands Vehicle Authority in the mobility chain), which has information on all vehicles registered to owners and in use in the Netherlands, including vehicle characteristics such as weight, fuel type and year of manufacturing, and retrofitted installations. For each vehicle category,

Statistics Netherlands provides detailed data (see Statistics Netherlands, [StatLine](#) and the [survey description](#) in Dutch).

The annual mileages for different types of vehicles (2) are calculated by Statistics Netherlands from odometer readings collected by the RDW. The RDW database contains odometer readings from all road vehicles that have been to a car maintenance shop for maintenance or periodic inspection, as part of an odometer anti-tampering legislation. Every year, Statistics Netherlands uses this data combined with RDW data on vehicle characteristics to derive both total as well as average annual mileages for different vehicles types. This methodology is applied to derive average annual mileages for passenger cars, light-duty and heavy-duty trucks and buses. The resulting mileages are subsequently corrected for the amount of kilometres driven abroad. Brief descriptions (in Dutch) of the research by Statistics Netherlands (CBS) on the vehicle kilometres travelled of [passenger cars](#), [vans](#), [buses](#), [lorries/road tractors](#), and [special purpose vehicles](#) can be found on the CBS-website. More comprehensive methodological descriptions on how the vehicle kilometres are calculated are available for:

- [Passenger cars](#) (Molnár-in 't Veld 2014);
- [Special purpose vehicles](#) (Kampert et al., 2014);
- [Buses](#) (Molnár-in 't Veld and Dohmen-Kampert, 2011);
- [Motorcycles and Mopeds](#) (Molnár-in 't Veld et al., 2014).

For earlier years of the time series, odometer readings were not yet available, therefore other data sources were used. The data for lorries and road tractors from 1990-1993 and buses from 1990-1997 have been derived from the so-called BedrijfsVoertuigenEnquête (Commercial vehicle survey), as described in CBSa (several volumes). The vehicle kilometre data for lorries and road tractors from 1994-2000 have been extrapolated by means of economic growth data for the transport sector.

The vehicle kilometres travelled in the Netherlands by foreign vehicles (3) are estimated by Statistics Netherlands using several statistics. The vehicle kilometres travelled by foreign passenger cars are divided into kilometres travelled on trips including overnight stay (holidays, business trip) and kilometres travelled on trips without overnight stay (commuting, shopping, family visits, day trips). An annual survey on lodging accommodations ('Statistiek Logiesaccomodaties') is used to estimate the number of kilometres travelled during trips with overnight stay. The estimation of kilometres travelled on trips without overnight stay is based on a German survey into transport intensity at 9 German-Dutch border-crossings, carried out in 1998, 2003, 2008 and annually from 2012 onwards. The years in between have been interpolated. The information available from the German-Dutch border-crossings was also used to estimate vehicle kilometres travelled for the years 1990-1997. Data are also derived from UK travel trends from 1999-2013 and Reisonderzoek België 2004-2012, and ever since both surveys are updated every year. The vehicle kilometres travelled by foreigners during 1990-1997 has been extrapolated with the use of data from the Dutch Mobility Survey (OVG) and the ratio between the kilometres driven by Dutch citizens and foreigners during 1998-2004.

The vehicle kilometres travelled by Dutch vans are based on odometer readings in combination with the vehicle characteristics data from the Road Authorities (RDW). To divide the total number of vehicle kilometres for Dutch vans by territory, data are used from the Goods Transport Survey, Eurostat, and, for early years of the time series, the 1993 survey of Commercial Vehicles (Bedrijfsvoertuigenenquête). The use of vans is largely regional. If they cross the border it will often be limited to border transport. This applies not only to the use of Dutch vans but also to foreign

vans on Dutch territory. There are no data available on kilometres travelled by foreign vans on Dutch territory. It was assumed that the vehicle kilometres travelled by Dutch vans abroad are equal to those of foreign vans on Dutch territory. From the Goods Transport Surveys from 1997 to 2008 it was derived that the kilometres of Dutch vans on foreign territory is on average 4 percent of the total kilometres driven. According to the assumption made, the total kilometres of foreign vehicles driven on Dutch territory has been equated with Dutch vehicle kilometres abroad. In 2012 the Goods Transport Survey (conducted by Statistics Netherlands) was expanded with additional questions about vans. From this study followed that of the total kilometres driven by Dutch vans in 2012 on average 4,1 percent is driven on foreign territory. This is close to the 4,9 percent reported from the 2016 Van Survey.

The vehicle kilometres travelled with foreign lorries and road tractors are derived from statistics concerning "goods transport on the roads"<sup>1</sup> as well as similar data based on Goods Transport Surveys from other EU countries as collected by Eurostat. The vehicle kilometres travelled with foreign buses are determined by using a model which is divided into 4 sections. The main sources per section are:

1. Transport by foreign coaches in the Netherlands for stays of more than one day. The main source is a CBS tourism survey on accommodation (CBSb, several volumes) with data concerning the number of guests, overnight stays and destinations per country of origin. Travelled distances are calculated with a route planner.
2. Transport by foreign coaches in the Netherlands for day trips (so without overnight stays). The main sources are a CBS survey on daytrips and 'UK Travel Trends' (from 1998).
3. Transport by foreign coaches through the Netherlands (drive through). For this purpose data have been used from 'UK Travel Trends' and the Belgian Travel Survey. In addition to this a route planner was used to calculate distances from border to border.
4. Transport by foreign buses in the Netherlands as part of regular bus services in the border regions. For this purpose information has been used from timetables (<http://www.grensbus.nl/> and "<http://wiki.ovinnederland.nl>). Besides this Google Maps was used for a division of the bus lines into kilometres inland and abroad.

Also in case of the estimation of foreign coaches in the Netherlands several additional sources from different countries have been consulted, for instance:

- Report "Reiseanalyse Aktuell RA" (Forschungsgemeinschaft Urlaub und Reisen (FUR), 2002-2017): total number of holiday trips by Germans of 5 days and longer, number of holiday trips by Germans to the Netherlands and percentage of holiday trips abroad by Germans by bus.
- Statistics on incoming tourism: percentage of foreign guests travelling to the Netherlands by bus.
- "Reisonderzoek" (Algemene Directie Statistiek en Economische Informatie, 2000-2016) Belgium: number of holiday trips to the Netherlands, total and by bus.
- "UK Travel Trends" (Office for National Statistics, 2000-2016): number of holiday trips by UK residents to the Netherlands, total and by bus
- "Movimientos turísticos de los españoles (FAMILITUR)" (Instituto de turismo de España, 1999-2015): number of holiday trips by Spaniards to the Netherlands, total and by bus.
- "KNV statistiek touringcarvervoer" (Panteia, 2004,2006, 2008, 2010-2017): occupancy rate of Dutch coaches.

---

<sup>1</sup> Based on the Goods Transport Survey

The way the vehicle kilometres of foreign special purpose vehicles on Dutch territory are calculated is described in a methodological report on Vehicle kilometres by special purpose vehicles (Kampert et al. 2014). A major part of these data has been published in CBS Statline, namely the vehicle kilometres travelled by [passenger cars](#), [vans](#), [lorries](#), [road tractors](#), [buses](#) and [special purpose vehicles](#).

### **Allocation of vehicle kilometres to road category**

For the emission calculations, a distinction is made between three road types: urban, rural and motorway. The road type distributions for different vehicle types are derived from Goudappel Coffeng (2010). In this study, a national transport model was used to estimate the distribution of total vehicle kilometres travelled on urban roads, rural roads and motorways, for passenger cars and light and heavy-duty trucks. Subsequently, data from number plate registrations alongside different road types throughout The Netherlands were used to differentiate these distributions according to fuel type and vehicle age. In general, it was concluded that the share of gasoline passenger cars on urban roads is higher than on motorways. Also, the fleet on motorways on average is younger than on urban roads. These differences can mainly be related to differences in average annual mileages: higher mileages in general result in higher shares of motorways in total mileages. For the 1990-1997 period, the allocation of total vehicle kilometres travelled per vehicle type to the different road types is based on the figures from Statistics Netherlands about the use of roads ('*Statistiek van de wegen*'). The road type distribution of public transport buses and touring cars is derived from Den Boer et al. (2015). *Table 3.1* shows the allocation of total vehicle kilometres travelled in the Netherlands according to road type for the different types of road vehicles.

The allocation of vehicle kilometres to road types of light duty vehicles is most strongly related to the annual mileages of these vehicles (Ligterink, 2017b). In the current approach, the mileages of individual vehicles is used to assign these mileages to the road types. The equations used for annual mileages (jrkm) between 5000 and 50,000 kilometres are:

- $\text{urban}[\%] = 0.46468 - 1.411\text{e-}05 * \text{jrkm} + 1.4092\text{e-}10 * \text{jrkm}^2$
- $\text{motorway}[\%] = 0.23964 + 1.0711\text{e-}05 * \text{jrkm} - 8.0114\text{e-}11 * \text{jrkm}^2$
- $\text{rural}[\%] = 100\% - \text{urban}[\%] - \text{motorway}[\%]$

Beyond the range on 5000 to 50,000 the fractions are kept constant.

This result leads to a bottom-up estimates of the total kilometres urban, rural, and motorway, with an appropriate fleet composition per road type. However, for the total kilometres per road type (without specific fleet composition) other results, as discussed above, are used. Therefore, the totals are scaled to match these totals. In order to maintain the proper average emission levels, per vehicle, which vary substantially per road type, the scaling is corrected so that emission per vehicle does not vary with the totals used.

### **3.3.1 Cold starts**

For the years 2018 and up the emissions occurring from cold starts were calculated within the bottom-up approach. For the preceding years, i.e. 1990 till 2017, fractions of NO<sub>x</sub>, N<sub>2</sub>O, VOS, PM<sub>10</sub>, NH<sub>3</sub>, CO and EC total emissions on rural and urban roads were estimated based on literature review or interpolated values between the estimates. Subsequently these fractions were multiplied by the total emissions on rural and urban roads to calculate the cold start emissions on the respective road types for all road vehicle types (except motorcycles and mopeds) and fuels.

The number of cold starts per road type for a specific vehicle type and fuel type were calculated and aggregated to a total number of cold starts per vehicle and fuel type. In 2022 the ODIN data was analysed to determine the average trip length with a cold engine, based on a minimum of 2 hours parking. For very short trips about 50% are with cold starts, for longer trips this increases to about 80%. This is the basis of the relation between the number of cold starts and annual mileages of vehicles. The number of cold starts per year is calculated in the bottom-up approach using the formula:

- Light-duty vehicles: cold start per year =  $600 * jrkm / (jrkm + 5000)$
- Heavy-duty vehicles: cold starts per year =  $250 * jrkm / (jrkm + 5000)$

Where jrkm is the annual mileage of the individual vehicle. A cold start is defined as a start after at least two hours engine off.

On average, based on the assumptions about the percentage of cold starts per motive, it has been determined that approximately 60% of the starts are cold starts. The total number of cold starts per travelled kilometre is therefore 0.04. The equation is fitted to match the average trip length per cold start with the average annual mileage in the Netherlands. The underlying assumption is that with higher annual mileages the trips are longer and the number of cold starts per kilometre driven is less. The maximum amount of cold starts per year is based on typical commuting, with two cold starts per working day, and another two in the weekend. Heavy-duty vehicles are expected to have one cold start per working day, when in normal use.

The cold starts and subsequently the related emissions, occur solely on rural and urban roads. The allocation of cold starts inside and outside urban areas is based on the distribution of the number of households inside and outside urban areas, combined with differences in vehicle ownership per household between non-urban and urban areas. Based on this information, it was estimated that approximately 95% of all cold starts take place within urban areas, and the remainder takes place on rural roads.

### 3.3.2 Mopeds and motorcycles

Average annual mileages for motorcycles and mopeds were derived by Statistics Netherlands in 2013 using a survey among owners, as is described in more detail in Molnár-in 't Veld et al. (2014).

- [Motorcycles and Mopeds](#) (Molnár-in 't Veld et al., 2014).

These average annual mileages are further specified based on age and odometer standings. The vehicle kilometers for mopeds, motorcycles and other light 2-, 3- or 4 wheeled vehicle categories are estimated bottom-up based on a function relating the age of the vehicle to the yearly kilometers driven.

For mopeds and heavy quads and tricycles the function is fitted to odometer readings from the RDW. For mopeds, speed-pedelects and light quads and tricycles these data are not stored and the function is based on a comparison between the registered vehicles (by RDW) and the vehicles seen on the road (though license plate scans). The latter research is set to be published in the course of 2023. The total mileages for lcat vehicles are scaled to the values that have been published by CBS. Table 3.15b shows the number of vehicle kilometers for the different vehicle categories under moped/motorcycles.

## 3.4 (Implied) Emission Factors for road transport

### 3.4.1 VERSIT+ emission factors for air pollutants

The emission factors per vehicle class and road type for NO<sub>x</sub>, PM<sub>10</sub>, PM<sub>2.5</sub>, VOC (HC), NH<sub>3</sub>, N<sub>2</sub>O, CH<sub>4</sub> and CO are derived annually from TNO. TNO uses the VERSIT+ emission factor model to calculate these emission factors. The following formula is used to determine the emission factors per vehicle class and road type:

$$\text{Emission factor} = \text{BASw} + \text{BASw} * (\text{AGEw}-1)$$

Where:

BASw	Emissions per vehicle kilometre travelled for a hot engine, excluding the effect of ageing;
AGEw	The effect of ageing on “hot driving”, depending on the year of use;

The resulting emission factors per vehicle class and per road type for CO, VOC, NO<sub>x</sub> and PM<sub>10</sub> are shown in *Table 3.11*. Below a brief description is given of the backgrounds for ascertaining the parameters in the formula above. Separate emission factors exist for retrofitted vehicles (Van Asch et al. 2009, Van Asch en Verbeek, 2009, Vermeulen et al., 2013).

#### ***In-use compliance programme and dedicated measuring programmes***

Since 1987, the basis for the emission factors of EU- regulated components (CO, VOC, NO<sub>x</sub> and PM<sub>10</sub>) has been the annual in-use compliance programme of TNO. As part of this programme, every year passenger cars and light and heavy-duty trucks (including many common makes and models) are tested under laboratory circumstances. In addition, supplementary (real-world) measurements are conducted on the vehicles. The selection process is designed to provide a good reflection of the total fleet of vehicles on Dutch roads over the years. In this selection process, the programme takes account of vehicle sales, type of fuels, vehicle class (Euro1, Euro2, etc.) and year of manufacturing. The vehicles were, in the past, obtained by writing to the users of the selected vehicle types and asking whether or not they would be willing to submit their vehicle for a test. The response to this request is relatively low, about 25%, and has been relatively constant in recent years. As part of the final choice of the vehicles to be tested, an important criterion is that there is sufficient spread in mileages and regular maintenance. In addition, both privately owned and leased vehicles are tested. In this way, the tested vehicles reflect the average usage and maintenance condition of the total fleet of vehicles in the Netherlands. Nowadays, vehicles are often provided by rental companies and commercial parties.

When they are submitted for testing, the vehicles are subjected to an NEDC type approval test, after which the measurement values are compared with the type approval values for the relevant vehicle and with the applicable emission standards. The vehicles that did not pass the test were repaired (if possible) and measured again. In recent years there has been a sharp decline in the number of cars that do not comply to the relevant emission standards. On average petrol fuelled cars always comply, for diesel cars this is the case to a lesser degree (Kadijk et al. 2015; Ligterink et al. 2012; Ligterink et al. 2013).

Recent results show that a fraction of petrol vehicles drive around with serious defects that increase the emissions significantly. (Kadijk et al. 2020, Kadijk et al. 2018, Ligterink et al. 2019) This is

confirmed by remote sensing results. (Hoofman et al. 2020, Carslaw et al. 2019).

For the purpose of calculating the emissions from passenger cars TNO uses the measured emission factors before any maintenance is conducted. As a result, poorly tuned and/or poorly maintained vehicles are also included in the emission calculation. In order to prevent underestimation of real-world emissions, during the course of time the emphasis of the in-use compliance programme has moved more and more towards mapping of real-world emission performances instead of the execution of European NEDC type approval test cycles on new vehicles.

### **Hot engine basic emission factors (BASw)**

Since 2005, TNO uses the VERSIT+ Transport emission model to calculate the basic emission factors from the emission measurements database. With the use of VERSIT+, emission factors can be calculated for different transport situations and scale levels. The emission factors follow from various analysis fed by different kinds of measuring data.

VERSIT+ LD (light-duty) has been developed for light-duty vehicles, i.e. passenger cars and light-duty trucks. The model can be used to estimate emissions under specific driving conditions (Ligterink & De Lange, 2009). For the determination of the emission factors (BASw) of light-duty vehicles, first the driving behaviour dependence and the statistical variation per vehicle has been investigated. Next the results have been used in a model with currently more than 50 light-duty vehicle categories for each of the 5 emission components. The resulting model separates optimal driving behaviour and vehicle category dependencies.

Pollutant emission levels from road vehicles are strongly influenced by driving circumstances. Representative real-world driving cycles are required to determine emission factors. The driving cycles for light-duty vehicles in the Netherlands have been updated in 2015 based on an extensive measurement programme (Ligterink, 2016). In total 108 hours of on-road driving were recorded, distributed over urban roads, rural roads and motorways with varying speed limits. The driving cycles that were previously used were determined in 2001. Since it is unknown how driving dynamics have evolved between 2001 and 2015, it was decided that the new driving cycles would only be used to determine emissions factors for Euro-5 and Euro-6 cars, being the dominant vehicle categories on the road in 2015. This means that the impact of the new driving cycles on the emission time series for passenger cars and light-duty trucks slowly phases in starting in 2009 when the first Euro-5 vehicles entered the vehicle fleet.

VERSIT+ HD (heavy-duty) (Riemersma & Smokers 2004) was used to predict the emission factors of heavy-duty vehicles (i.e. lorries, road tractors and buses). For older vehicles VERSIT+ HD uses input based on European measurement data. These data have been obtained with less realistic tests, meaning that in some cases only the engine has been tested and in other cases measurements have been executed with several constant engine loads and engine speeds (rpm). For newer vehicles (Euro-III – Euro-VI) measurement data are available with closer resemblance of the real world usage of the vehicles (Ligterink et al. 2009). These new data are based on realistic driving behaviour, both from on-road measurements and measurements on test stands, have been used in a model to represent emissions during standard driving behaviour. The emission factors for buses often originate from test stand measurements with realistic driving behaviour for regular service buses.

To determine the emission factors for heavy-duty vehicles, the PHEM model developed by the Graz



University of Technology was used, also using measurement data from TNO. For pre-Euro-III, the emission factors are still based on this model. Euro-III and later emission factors are based on in-house, on-road measurements (Ligterink et al., 2012). As with VERSIT+ LD, the input is composed of speed/time diagrams, which make the model suitable for the prediction of emissions in varying transport situations. In VERSIT+ HD, the most important vehicle and usage characteristics for emissions are determined. For Euro-V, the actual payload of a truck is important for NO<sub>x</sub> emissions because the operation of the SCR relies on sufficiently high engine loads, resulting in high temperatures which are needed for the SCR. The payload of trucks were determined from on-road measurements on the motorway (Ligterink 2015). The usage characteristics of trailers was also collected from these data. PM emissions also have a strong correlation with payload and the resulting engine load, which is taken into account in the emission factors (Stelwagen & Ligterink, 2015). Recent results show that Euro-VI trucks perform well on the motorway, but not so in urban areas. (Vermeulen et al. 2022, Vermeulen et al. 2021, Ligterink et al. 2021a).

Over the years, for most vehicle categories many measurement data have become available, which means that the reliability of VERSIT+ is relatively high. However, individual vehicles can have large deviations from the average (Kraan et al., 2014). TNO has even observed large variations of the measured emissions between two sequential measurements of the same vehicle. This is not the result of measurement errors, but of the great sensitivity of the engine management system, especially on petrol and LPG vehicles, to variations in how the test cycle is conducted on the dynamometer. Moreover, diesel emission control systems also show a great sensitivity to variations in test circumstances. It has been paramount to ensure that the emissions correspond to the on-road results. VERSIT+ is used to predict emissions in specific driving situations, the commercial software EnViVer links the emission model to traffic simulations, but can also be used to predict emission factors on a higher level of aggregation, like in this case.

**Cold start emissions (BASc and PERCc)**

The cold start emission is seen as an absolute extra emission per cold start (expressed in grams per cold start). This emission is calculated separately to the emissions of the warm-up motor (and exhaust-gas after treatment). The emission factor is determined as follows:

$$\text{Emission factor} = \text{BASc} * \text{AGEc} / \text{PERCc}$$

Where:

- BASc                                    total extra emissions caused by driving with a cold engine (without ageing)
- AGEc                                    the effect of ageing on the extra emissions caused by “cold start”,  
depending on the year of use
- PERCc                                    Average number of cold starts per kilometre travelled

The resulting emission factors per vehicle class and per road type for CO, VOC, NO<sub>x</sub>, PM<sub>10</sub>, NH<sub>3</sub>, N<sub>2</sub>O and EC are shown in *Table 3.11*.

The measurements for determining cold start emissions are performed by testing the vehicles on the dynamometer using a real-world driving cycles with both a cold engine as well as a warmed-up engine. The difference in emissions between the cold engine and the warmed-up engine for the whole cycle is the cold start emission. For spark-ignition engines the cold-start emission dominates the total emission on the test. For compression ignition engines the effects of cold start has only limited significance. The average number of cold starts per kilometre travelled are given in 3.3.1.

### **Aging (AGEw and AGEc)**

The effects of vehicle aging are determined using data from the in-use compliance programme of TNO. The sample includes multiple vehicles with different odometer readings of various vehicle types. By comparing the emissions at different odometer readings a trend in emission increase or decrease can be observed over the course of time. The running-in period of several thousand of kilometres is not taken into account.

A distinction is made between the effect of ageing on the emission factor with a warm engine and exhaust gas treatment techniques and the effect of ageing on the extra cold start emissions. In the case of a warm engine the change in emissions due to ageing is primarily determined by the fact that the conversion efficiency of the warm catalyst declines in the course of time and is also caused by ageing of technical aspects of the motor in the form of, for example, wear of piston rings and valves. In the case of a cold engine the change in emissions due to ageing is caused by the fact that it takes longer for the exhaust gas aftertreatment device to reach operational temperature (and its maximal conversion performance). The methodology is described in detail in Van Zyl et al. (2015a). The updated aging factors are described in (uCARE D1.2, 2022)

In a 2017-2018 measurement programme on the emission performance of older petrol cars, it was found that 1 in 6 showed large increases in NO<sub>x</sub> emissions. The effect is significant in the total emissions of petrol vehicles, and it was taken into account in the overall emission factors. It is expected that from an age of 10 to 15 years the NO<sub>x</sub> emissions of petrol vehicles (Euro-3 to Euro-5) increase to 300 mg/km (Kadijk et al. 2018).

### **Real world emission measurements**

From 2014 on almost all emission factors for road vehicles are determined in on-road testing and monitoring. This includes many of the before mentioned aspects which were previously added as correction factors on the measured emissions. The analyses of the measurement data determines if systematic effects, for cold start and other conditions are found, and need to be corrected for. The methodology used for the in-service testing programmes by TNO and the subsequent analysis of measurement data and the calculation of representative emissions factors for over 300 different vehicle types are described in detail in Spreen *et al.* (2016).

### **Air conditioner effects (ACCESSORIES and PERCac)**

The percentage of new passenger cars that are equipped with air conditioners has increased rapidly in recent years. The RAI has calculated that this percentage was 45% in 1998 and in recent years a large majority of (new) cars is equipped with air conditioners. For the determination of the correction factors for the use of air conditioners, measurements performed by EMPA [Weilenmann, 2005] are used. EMPA has measured vehicles under different circumstances (regarding temperature and time in the sun). TNO has used these measurements to derive correction factors for the Dutch situation. The only EMPA measurements used are the measurements where the vehicle had to be kept at a certain temperature by the air conditioner.

The most important reason for the negative effects on emissions resulting from the use of air conditioners is that the engine management system is generally not adjusted to the use of an air conditioner because during the vehicle type approval test, the air conditioner can remain turned off. The use of an air conditioner affects the operation of the lambda control system, which causes the conversion efficiency of the catalyst to decrease. In addition, even without deterioration of the lambda control, the increase in the total energy being generated leads to increased emissions and

fuel consumption.

For diesel vehicles, an air conditioner operating at full capacity sometimes leads to a decrease in emissions. The reason for this is that diesel engines emit more components resulting from incomplete combustion (CO and VOC) when the motor has a relatively low load than with a higher load. In some cases, the increased motor load that is linked with the use of the air conditioner therefore has a beneficial effect on the emissions. The effect on cold start emissions has not been assessed, but it is expected that there will be a neutral emission behaviour because a small increase in engine emissions (with a cold catalyst) will be compensated by a shorter warm-up time for the catalyst (due to the higher load on the motor). The fuel consumption, in contrast, will increase due to the increased load on the engine.

No data are known about the average use of vehicle air conditioners in the Netherlands. Research from France has shown that vehicle air conditioners are used on average 200 hours per year. TNO has calculated that the average passenger car is used for 570 hours per year. If it is assumed that air conditioners in vehicles in the Netherlands, due to the colder climate, are used for only 100 hours per year, and that the average driving speed does not differ between driving with the air conditioner on or off, then the percentage of kilometres that are travelled with the air conditioner on is approximately 18%.

With the shift to on-road emission testing for newer generations of vehicles, such correction factors are no longer applied. Effects of additional weight, wind, temperature, lights, etc. are included in the on-road test results. Therefore a correction of the emission factors for the use of air-conditioning is no longer necessary. Moreover, the efficiency of air-conditioning has improved significantly such that the results of the studies in the past can no longer be applied with confidence. Air-conditioning is now expected to affect the average fuel consumption by less than 2%.

### 3.4.2 Fuel consumption and fuel related emission factors

Until 2012 fuel consumption was derived from the vehicle kilometres travelled and specific fuel consumption (km/l) per vehicle type, as derived from surveys by Statistics Netherlands such as the PAP (Passenger Car Panel), the BVE (Commercial vehicles), and the motorcycle owners survey. These surveys have been discontinued. Therefore in 2013 and 2014 three projects were carried out by Statistics Netherlands and TNO to calculate fuel consumption and CO<sub>2</sub> emissions from road transport. The basic data used for all three calculations are derived from the national vehicle register and the odometer readings. For passenger cars the CO<sub>2</sub> emissions as measured during the type approval of the car were combined with insights on the difference in CO<sub>2</sub> emissions between type approval and real-world operation. For the calculation of fuel consumption and CO<sub>2</sub> emissions of lorries and road tractors a new model was used including new knowledge with respect to the loading of these freight vehicles. The research projects are described in more detail in Staats et al. (2014), Willems et al. (2014) and Kruiskamp et al. (2015). See:

- [Bottom-up calculation of CO<sub>2</sub> by passenger cars \(report in Dutch\)](#)
- [Bottom-up calculation of CO<sub>2</sub> by lorries and road tractors \(report in Dutch\)](#)
- [Bottom-up calculation of CO<sub>2</sub> by delivery vans \(report in Dutch\)](#)

The results of the surveys can be found on the CBS website:

- [Fuel consumption and CO<sub>2</sub> emissions of passenger cars in The Netherlands](#)
- [Fuel consumption and CO<sub>2</sub> emissions of lorries and road tractors in The Netherlands](#)

- [Fuel consumption and CO<sub>2</sub> emissions of delivery vans in The Netherlands](#)

The specific fuel consumption of the other vehicle types are still based on the old method. In order to directly allocate fuel-consumption-dependent emissions according to road type, ratio factors were determined using the VERSIT model (Lefranc, 1999), see also Section 3.4.1. With these ratio factors, the fuel consumption for the three road types can be derived from the average fuel consumption.

The emission factors for SO<sub>2</sub> and for heavy metals have been derived from the sulphur and heavy metal content of the motor fuels. *Table 3.7* shows the fuel quality data for various statistical years for calculating the emissions of SO<sub>2</sub> and lead. It is assumed that 75% of the lead leaves the exhaust as air-polluting particulates and that 95% of the sulphur is converted into SO<sub>2</sub>. The amounts of heavy metals in motor fuels are shown in *Table 3.6A*. It is assumed that the content of heavy metals (except lead) is independent of the statistical year.

### Real-world CO<sub>2</sub> emission factors for passenger cars and light duty vehicles

Real-world CO<sub>2</sub> emissions of passenger cars are calculated using a model based on fuel card data (Ruiter *et al*, 2019). This model links for each individual passenger car the fuel type, mass, power (kW), along with a build year dependency of vehicle technology, to the relevant CO<sub>2</sub> emissions. The power-to-mass ratio only defines vehicles with relatively high and low power, i.e. outside to the 'normal' power range (Ruiter *et al*, 2021). Fuel card data is used to determine the relationship between fuel consumption and fuel type, mass, power and build year, which is then be used for all passenger cars and vans. The average power-to-mass contribution is only relevant for petrol and diesel vehicles with 'unusual' power-to-mass ratios. The dataset upon which this model is based is described by Gijlswijk *et al* (2020). For each individual passenger car or van, the relevant vehicle properties are retrieved from RDW-data based on the license plate number and then used to determine a CO<sub>2</sub> emission in g/km per vehicle. For vehicles running on alternative fuels (CNG/LNG, LPG or a combination of gas and petrol), the CO<sub>2</sub>-emissions are first calculated based on the petrol formulas and then converted using a conversion factor. Fuel usage and CO<sub>2</sub> emissions on urban roads are considerably higher than on rural roads and highways. Averaged over the categories emissions on rural roads are 63% (+/-8%) and motorways 65% (+/-14%) compared to urban roads. For modern vehicles, the following ratios are calculated from real-world measurements (Gijlswijk, Ruiter, Indrajana, Stelwagen, & Ligterink, 2021).

Personcars petrol, LPG and CNG

- **B<sub>LPAB</sub> = 63.3%** rural relative to urban
- **S<sub>LPAB</sub> = 79.0%** motorway relative to urban

Personcars diesel: (higher motorefficiency at lower load)

- **B<sub>LPAD</sub> = 74.6%** rural relative to urban
- **S<sub>LPAD</sub> = 68.2%** motorway relative to urban

Light commercial vehicles: (mainly diesel but with high air drag and weight)

- **B<sub>LBA</sub> = 83.2%** rural relative to urban
- **S<sub>LBA</sub> = 92.1%** motorway relative to urban

The ratios are used for calculating the CO<sub>2</sub>-emissions and fuel consumption per road type.

### 3.4.3 Other emission factors

Table 3.11 shows the emission factors for NH<sub>3</sub>, which were derived from Stelwagen & Ligterink (2015a). EC emission factors were derived from Stelwagen & Ligterink (2015b). Emission factors for alternative drivelines and alternative fuels were derived from Ligterink et al. (2014). The emission factors for evaporative VOC emission are shown in Table 3.2. The emission factors were estimated using the methodology from the EEA Emission Inventory Guidebook, as described in Section 3.2.4. Table 3.3A shows the emission factors used for wear of brake linings, tyres and road surface, whereas Table 3.3B shows the share of wear emissions that is assumed to be emitted to air, water and soil. The heavy metal composition of particulate matter emission due to wear is shown in Table 3.6B. The data in this table concerning brake wear originate from (RWS 2008). Most recent corrections of NH<sub>3</sub> emission factors are based on the 2022 measurement program for the Dutch government (to be published).

Table 3.4 shows an example set of the emission factors for leakage losses and combustion of lubricant oil. The basic data for converting to emission factors according to the age of the vehicle are shown in Table 3.5. The heavy metal factors for lubricant oil in mg per kg of oil (leakage and consumption) are shown in Table 3.6A.

### 3.4.4 VOC species profiles

For the VOC species profiles that are used to break down VOC emissions into individual components, a distinction is made according to the type of fuel. For petrol vehicles, a distinction is also made according to those with and without a catalyst, because the catalyst oxidizes certain VOC components more effectively than others. The profile shows the fractions of the various VOC components (approximately 40) in total VOC emissions. The VOC profiles per type of fuel originate from literature studies (VROM, 1993 and Ten Broeke & Hulskotte 2009). They are shown in Tables 3.10A and 3.10B. These literature studies are also used to derive PAH profiles, expressed in grams/kg of VOC emissions studies. Tables 3.10C and 3.10D show these profiles per type of fuel, where – like the VOC profiles – a distinction is made between petrol used with and without a catalyst and diesel fuelled vehicles from before and after 2000. In addition, petrol for two-stroke engines has a deviating profile. The VOC components in the evaporative emissions are also calculated with a VOC profile that was ascertained by TNO (see Table 3.10A). This profile is based on “Emissiefactoren vluchtige organische stoffen uit verbrandingsmotoren” (VROM 1993) but has been modified because the maximum benzene and aromatics content of petrol was reduced on 1 January 2000 due to EU legislation. The stricter requirements regarding benzene are shown in Table 3A below.

The reduction of the content of benzene and aromatics in petrol has direct consequences for the benzene and, to a lower extent, aromatics content in the evaporative emissions of these petrol-fuelled vehicles. The link between the benzene content in petrol and the benzene content in the exhaust gas, however, is complex: at low speeds, according to Heeb et al. (2002), the benzene content in the exhaust gas declines by 20-30% when the benzene content in the petrol declines from 2% to 1% per volume, while at high speeds at rich engine operation the benzene content in the exhaust gas actually increases. Because this relationship is too complex to model in the Emission Inventory, and because the decline of the benzene content in exhaust gas is relatively small on balance, the transport task group decided to leave the benzene content in the exhaust gas unchanged. Moreover, such effects are observed with older technology, and likely not to be so for Euro-5 and Euro-6 petrol vehicles. However, the benzene content in petrol and in petrol vapour has

been modified. In addition, the toluene content in petrol and petrol vapour has been corrected with retroactive effect for historical years.

**Table 3A**  
Several emission-relevant requirements for motor petrol according to EN228

Parameter	1999	2000	2009
Benzene content, vol. % (maximum)	5	1	1
Aromatics content, vol.% (maximum)	-	42	35
Vapour pressure summer kPa (maximum)	80	60	60
Sulphur content, mg/kg (maximum)	500	150	10

**Table 3B**  
Emission profile for the emission of benzene (percentage by weight)

	Petrol			Petrol vapour	
	1999 and before	2000 and later		1999 and before	2000 and later
Benzene <sup>1)</sup>	2.5	0.8		1	0.3
Toluene	15	12.5		3	2.5
Xylene	-	-		0.5	0.5
Aliphatic hydrocarbons (non-halogenated)	35	60		95	97
Aromatic hydrocarbons (non-halogenated)	65	40		5	3

<sup>1)</sup> A factor of 1.2 was used to convert the volume percentage of benzene to the weight percentage.

Although there is no information on structural research regarding the enforcement of these internationally-applicable agreements, based on the best available information it is assumed that structural violation of these requirements concerning motor petrol does not occur in the Netherlands (Ligterink, 2020). In Belgium, it appeared that petrol indeed contained less than 1% of benzene by volume in 2000, while in 1999, this was still more than 1% by volume (FAPETRO 1999 & 2000). Several of the emission profiles linked to petrol or petrol vapour have therefore been modified. Based on the available information (EU, 2002 & FAPETRO 1999 & 2000; Machrafi & Mertens, 1999; Shell, 2000), it was decided to use two emission profiles for benzene and benzene vapour, one before 1999 and one after. Because the benzene content had not yet been changed in the Netherlands in 1999 (Machrafi and Mertens 1999) it was decided to implement the changes based on analyses in Belgium (FAPERTR0 2000) in the expectation of the research in the Netherlands, which hopefully will be conducted in the near future. According to European legislation, every Member State must report on fuel quality during the previous year on June the 30<sup>th</sup> of every year. The Dutch monitoring results are published on the EU-website. Table 3B shows the emission profiles for the statistical year 1999 and before, and for the statistical year 2000 and afterwards.

## 3.5 Uncertainties

Uncertainties of road transport emissions were estimated in two studies. In 2013, TNO carried out a study to improve the knowledge on uncertainties of pollutant emissions from road transport (Kraan et al., 2014). Using a jack-knife approach, the variation in the different input variables used for estimating total NO<sub>x</sub> emissions from Euro-4 diesel passenger cars was examined, including emission behaviour of the vehicles, on-road driving behaviour and total vehicle kilometres driven. It was concluded that the 95% confidence interval lies at a 100% variation in emission totals if all aspects are added up. It is unclear if these results hold for more recent or older generations of (diesel) passenger cars.

Test procedures have been improved in recent years, but the number of vehicles tested has decreased over the years. This method to determine uncertainties proved to be time-consuming. Therefore it was decided to use an expert-based approach to estimate overall uncertainties of road transport emissions. In 2016, an expert workshop was organized with the members of the Task Force Transportation in the Dutch PRTR to discuss and estimate the uncertainties in the activity data and emission factors used for the emission calculations for the transport sector. Uncertainties were estimated at the level of the NFR source categories. The setup and outcomes of the workshop are described in Dellaert & Dröge (2017). The report also compares the estimates resulting from the workshop to estimates reported by other countries and default estimates from the Emission inventory guidebook. The resulting uncertainty estimates for road transport are provided in table 3C.

Road transport emissions are estimated using a fuel sold approach. Uncertainty in fuel sales data for road transport is deemed to be rather small, as is shown in Table 2.5. For gasoline and diesel, uncertainty is estimated at 2%. The calculation of road transport emissions is based on a bottom-up approach though, using vehicle kilometres travelled for different vehicle types as activity data. The uncertainty estimates for the activity data in Table 3C below were estimated for the vehicle kilometres travelled. Uncertainty is estimated to be low, since these data are calculated car register data and odometer readings for all motorized road vehicles in the Netherlands (with the exception of motorcycles and mopeds). Odometer readings are recorded every time a vehicle visits a garage for maintenance or repairs to prevent tampering. As such, the odometer readings are considered to present accurate data on vehicle kilometres driven by Dutch vehicles. The share of kilometres driven abroad and the number of kilometres driven by foreign kilometres in the Netherlands is more uncertain though. Since these shares are higher for heavy duty vehicles, uncertainty in activity data for heavy duty vehicles is estimated to be higher than for light duty vehicles. Vehicle kilometres travelled by motorcycles and mopeds are estimated using average annual mileages derived from a survey in 2013. Uncertainty in these data is deemed to be higher.

Uncertainty in emission factors is deemed to be smallest for NO<sub>x</sub>, since NO<sub>x</sub> has been measured consistently under real world operations in the last decade. Uncertainty in NH<sub>3</sub>, EC and PM emission factors are higher since these components have not been included regularly in measurement campaigns. Uncertainty in emission factors for gasoline evaporation and for wear of tyres, brakes and road surface is considered to be very high as well due to lack of monitoring data. This holds especially for the PM<sub>2.5</sub> wear emissions. Emission factors for motorcycles and mopeds are also considered to be uncertain due to lack of measurements.

With the use of monitoring data for the determination of emission factors, the post-diction of

emissions has become standard practice. In many cases the deviation is determined, and forms the basis of accepting the measurement results as significant. The variation between makes and models is the largest source of uncertainty at the moment.

**Table 3C**  
Uncertainty estimates for road transport (Dellaert & Dröge 2017)

NFR	Fuel type	Uncertainty activity data	Uncertainty implied emission factors					
			NO <sub>x</sub>	SO <sub>x</sub>	NH <sub>3</sub>	PM <sub>10</sub>	PM <sub>2.5</sub>	NMVOC
<b>1A3bi Passenger Cars</b>	Petrol	5%	20%	20%	200%	200%	200%	100%
	Diesel	5%	20%	20%	100%	50%	50%	100%
	LPG	5%	20%		200%	200%	200%	50%
<b>1A3bii Light duty vehicles</b>	Petrol	5%	20%	20%		200%	200%	50%
	Diesel	5%	20%	20%		50%	50%	100%
	LPG	5%				200%	200%	
<b>1A3biii Heavy duty vehicles</b>	Petrol	10%	20%	20%		200%	200%	
	Diesel	10%	20%	20%	100%	50%	50%	100%
	LPG	10%				200%	200%	
<b>1A3biii Buses</b>	Natural gas	5%						
	Petrol	5%	20%	20%		200%	200%	
	Diesel	5%	20%	20%		50%	50%	
	LPG	5%				200%	200%	
<b>1A3biv Mopeds &amp; motorcycles</b>	Petrol	20%	200%	20%		500%	500%	500%
	Diesel	20%	100%	20%		500%	500%	
<b>1A3bv Petrol evaporative emissions</b>	Passenger cars							200%
	Mopeds & motorcycles							500%
<b>1A3bvi</b>	Tyre wear					100%	200%	
<b>1A3bvi</b>	Brake wear					100%	200%	
<b>1A3bvii</b>	Road surface wear					200%	500%	

### 3.6 Points for improvement

VERSIT+ is a statistical emission model based on emission measurements. For this reason with every model update it is preferred to use as much new measurement data as possible. Version 3 of the VERSIT+ model has been developed in 2008. With this the statistical method has been renewed to achieve a better relationship between the instantaneous emissions and the vehicle's speed and



acceleration. The generic driving behaviour variables per trip have been replaced by instantaneous variables for any moment. With this optimal use is made of the different kinds of measurement data. More information about this subject can be found in Ligterink & de Lange (2009).

In recent years, the determination of emission factors relies more and more on on-road emission measurements, with poorly understood variations (Spreeen et al., 2016). The amount of data per car is set at a minimum of two hours, instead of the 45 minutes in the case of the older chassis dynamometer tests. However, currently it is examined how to make the VERSIT+ emission model more robust against (unexplained) variations in the input data. Another aspect that needs more attention herein is the intricacies of modern emission control technology, and the effect of exhaust gas temperature on its operation. This is subject of on-going research. However, the aim is to collect sufficient data such that the current approach remains statistical significant despite the variations.

## 4 Railways

### 4.1 Source category description

This chapter describes the methods that have been used to determine the emissions of rail transport in the Netherlands. This includes both passenger transport and freight transport. Most railway transport in the Netherlands uses electricity, generated at stationary power plants. Emissions resulting from electricity generation for railways are not included in this source category. This source category only covers the exhaust emissions from diesel-powered rail transport in the Netherlands. Diesel is mostly used for freight transport, although there are some diesel-powered passenger lines as well. This source category also includes emissions due to wear, which result from friction and spark erosion of the current collectors (pantographs) and the overhead contact lines. This results, among other things, in emissions of particulate matter, copper and lead from trains, trams and metros.

Emissions of air pollutants by railway transport in the Netherlands are reported in the NFR under source category 'Railways' (1A3C).

### 4.2 Activity data and (implied) emission factors

#### 4.2.1 Exhaust emissions from railways

The emissions of air pollutants from railway transport in the Netherlands are calculated using a Tier 2 methodology. The exhaust emissions of rail transport are estimated by multiplying the fuel consumption by emission factors per kg of fuel. Diesel fuel consumption for railways is derived annually from the Energy Balance, which uses different sources to construct the time series, as shown in *Table 4.1*. For recent years, fuel consumption data are derived from VIVENS (Association for joint purchase of energy for railway companies). For earlier years of the time series, data on diesel fuel consumption by railways was derived from NS (Dutch Railways). *Table 4.1* shows the fuel consumption figures and the origin of the data for the entire time series. The distribution of diesel consumption amongst freight and passenger transport from 1990 is based on data from NS

railways in 1990 (35% passenger) and is assumed constant until 2010 (with a recalculation in 2003 to 30% passenger). For 2020 the share of passenger transport is expected to have increased due to electrification of freight transport (Hilster et al., 2020) to over 50% (expert judgement by TNO). The share between 2010 and 2020 is calculated by linear interpolation. As of 2021 the location of the fuel sales, like at main ports and regional stations with diesel-fuelled passenger trains are used to allocate the diesel use to freight and passenger trains.

The emission factors for railways were derived from the National Institute for Public Health and the Environment (RIVM/LAE, 1993) in consultation with the NS (see *Table 4.2*).  $PM_{2,5}$  emissions are calculated from  $PM_{10}$  by using an emission profile. *Table 4.3* shows the assumed share of  $PM_{2,5}$  in the  $PM_{10}$  emissions. For the calculation of the  $NH_3$  emissions, default emission factors were derived from the EEA Emission Inventory Guidebook (Ntziachristos and Samaras, 2000).

The emissions factors for  $SO_2$  and heavy metals are derived from the sulphur and heavy metal content of the diesel fuel. *Table 3.7* shows the fuel quality data for various statistical years for calculating the emissions of  $SO_2$  and lead. It is assumed that 75% of the lead leaves the exhaust as air-polluting particulates and that 95% of the sulphur is converted into  $SO_2$ . The emissions of heavy metals are calculated by multiplying the fuel consumption with the emission factors that are based on the metal content of the fuels. The emission factors in grams per kilogramme of fuel are identical to the factors for diesel fuel for road transportation (*Table 3.6A*).

Emissions of different VOC and PAH species are derived from total VOC emissions using VOC and PAH species profiles ascertained by TNO Built Environment and Geosciences; these are equivalent to the diesel profiles for transport on the inland waterways (*Tables 5,7 A, B and C*) (VROM 1993).

The  $NO_x$ - emission factors were updated on the basis of measurements of  $NO_x$  in normal use of rail diesel engines (Ligterink et al. 2017a). Both a modern and an older diesel train showed high  $NO_x$  emissions, showing limited improvement over the years. Given the long idling periods and low-load operation it is expected that the emission factors are common for all diesel propelled trains.

$NO_x$  and PM emissions of specific trains that are used for building and maintenance of the railroad network were included by adding half of the reported emissions in van Mensch et al. (2022) to the calculated totals for the entire time series.

#### 4.2.2 Wear of overhead contact lines and carbon brushes

The calculation of wear emissions is based on a study conducted by NSTO (currently AEA Technology) in 1992 concerning the wear of overhead contact lines and the carbon brushes of the current collectors on electric trains (CTO 1993). The total emission of copper in 1992 was estimated by the NSTO at 20.7 tonne, of which 3 tonne was attributed to carbon brushes.

In combination with the electricity consumption for that year provided by the Dutch railways (approx. 1200 million kWh) and the fact that overhead contact lines are comprised entirely of copper, and carbon brushes are comprised of 25% copper, the total quantity of wear particles originating from overhead contact lines and current collectors can be determined per kWh of electricity consumption (overhead contact lines: approx. 15 mg/kWh; carbon brushes: approx. 10 mg/kWh). For trams and metros, the wear of the overhead contact lines is assumed to be identical per kWh of electricity consumption. The wear of current collectors is not included, because no information is available on this topic. Carbon brushes, besides copper, contain 10% lead and 65%

carbon.

Based on the NSTO study referred to above, the percentage of particulate matter in the total quantity of wear debris is estimated at 20%. Due to their low weight, these particles probably remain airborne. According to Coenen & Hulskotte (1998), approximately 65% of the wear debris ends up in the immediate vicinity of the railway, while 5% enters the ditches alongside the railway. According to the NSTO study, the remainder of the wear debris (10%) does not enter the environment, but attaches itself to the train surface and is captured in the train washing facilities.

The assumed share PM<sub>2.5</sub> in the PM<sub>10</sub> emissions for wear of overhead wires and carbon brushes is 100% (see Table 4.3).

### 4.3 Uncertainties

In 2016, an expert workshop was organized with the members of the Task Force Transportation in the Dutch PRTR to discuss and estimate the uncertainties in the activity data and emission factors used for the emission calculations for the transport sector. Uncertainties were estimated at the level of the NFR source categories. The setup and outcomes of the workshop are described in Dellaert & Dröge (2017). The report also compares the estimates resulting from the workshop to estimates reported by other countries and default estimates from the Emission inventory guidebook. The resulting uncertainty estimates for railways are provided in table 4A.

Activity data for railways is derived from the Energy Balance and uncertainty is deemed rather small. Emissions factors are rather uncertain due to a lack of measurements.

**Table 4A**  
Uncertainty estimates for railways (Dellaert & Dröge 2017)

NFR category	Type	Fuel type	Uncertainty activity data	Uncertainty implied emission factors				
				NO <sub>x</sub>	SO <sub>x</sub>	PM <sub>10</sub>	PM <sub>2.5</sub>	EC
1A3c Railways	Freight transport	Diesel	5%	100%	20%	100%	100%	100%
	Passenger transport	Diesel	5%	100%	20%	100%	100%	100%
	Pantograph wear	Electricity					200%	200%

### 4.4 Points for improvement

The current methodology to estimate emissions from railways could be improved regarding:

- The emission factors for railways are outdated and need to be updated, taking into account the different stages of the EU emission legislation for railway diesel engines. Emissions of passenger trains should be updated based on emission data of Stage IIIb engines, and exhaust particle emissions will be reviewed.
- Recent international studies provide show a wide range in non-exhaust rail emission levels, where Dutch results may be on the low side, excluding wheel, track and brake wear emission altogether. PM<sub>10</sub> emissions of wear and tear of train wheels and the train track are

not included for railways, but a review on (Hilster et al., 2020) recommends to include them. A meta-review could be performed to update the results and include the missing components.

## 5 Inland navigation

### 5.1 Source category description

This chapter describes the methods that have been used to calculate the emissions from inland navigation on Dutch national territory, which are reported in the NFR and used for air quality modelling. Please note that the methods used for calculation of GHG emissions in the National Inventory report are described in chapter 2. Inland navigation is defined as all motorized vessels that travel on the inland waterways in the Netherlands. Transport on the inland waterways comprises, among other things, professional freight transport, passenger transport and recreational craft.

The propulsion that is used in inland navigation for freight and passenger transport in the Netherlands is provided by diesel engines. The combustion processes that take place in these diesel engines cause emissions of air pollutants. The most important substances emitted are carbon dioxide, nitrogen oxides, particulate matter (PM<sub>10</sub>), carbon monoxide, hydrocarbons and sulphur dioxide. Carbon dioxide and sulphur dioxide are caused by the oxidation of the carbon and sulphur present in the fuel. The emissions of these substances therefore depend completely on the contents of carbon and sulphur in the fuel and quantity of fuel that is combusted. Nitrogen oxides are primarily caused by the high temperatures and pressures in the combustion engines, which causes the nitrogen present in the atmosphere to combine with oxygen. Carbon monoxide, hydrocarbons and particulates are products of incomplete combustion. The emissions of the latter substances therefore mainly depend on the technical properties of the engines and the way in which these engines are used.

The propulsion of recreational craft takes place using both petrol and diesel engines. With petrol engines, a distinction can be made between outboard engines (usually two stroke engines) and inboard engines (usually four stroke engines). Diesel engines are inboard engines. The most widely sold engines are small outboard engines. Petrol engines usually have an underwater exhaust, which results in a significant portion of the emitted substances dissolving in the water and therefore not entering the atmosphere. Diesel engines have an above-water exhaust. Nevertheless, diesel engines can also cause water pollution, especially when the cooling water from the motor is discharged through the exhaust.

Generally speaking, engines for recreational vessels are comparable with automobile engines. However, in terms of technology and the related emission properties, they are years behind in development. Because safety – and therefore the operational security of the engines – is a priority, especially with seagoing vessels, the petrol engines are adjusted to have a very rich mixture. As a result, CO and VOC emissions are significantly higher than those of comparable engines in road transport. In contrast, NO<sub>x</sub> emissions are negligible.

Besides the emissions resulting from the propulsion of inland shipping vessels, emissions of

volatile organic compounds (VOC) also take place due to de-gassing of cargo fumes by inland shipping vessels in the Netherlands. The de-gassing of cargo tanks to the atmosphere is often referred to as ventilating, to distinguish this from de-gassing to a vapour processing facility. Although the term does not properly indicate the actual process, in the present report "ventilating" will be used to indicate cargo fumes being released to the outside air. In principle, cargo fumes that remain in a cargo tank after unloading are blown into the air with the use of ventilating fans. This way, the next trip can begin with a clean tank. Partly as a result of government policy, there are exceptions to this process. Cargo fumes that are released when loading ships are classified as part of the emissions of the loading installation and are therefore not included in this report. These emissions are largely allocated to the industrial target group (refineries and chemical industry). The exceptions to this are the loading emissions during ship-to-ship transfer.

The emission calculation includes 30 different VOC species. The basis for this assumption is the transported quantity of other volatile organic substances and a rough estimate of the emission factors of these substances. They do not include the following:

- The emissions of cargo fumes via pressure release valves;
- Incidental emissions from cargoes to water or air resulting from accidents or careless handling;
- Emissions of fuel vapours from fuel storage tanks.

## 5.2 Activity data and (implied) emission factors

Different methodologies are used for calculating the emissions from freight shipping, passenger vessels and recreational craft. The methodologies are described below.

### 5.2.1 Professional inland shipping

The methodology for calculating the emissions of professional inland shipping was initially developed in 2003 as part of the so-called EMS-project (Emissions Monitoring Shipping), and has been refined since. The emission calculation is based on the energy consumption per vessel class, which is calculated from the travelled vessel kilometres. For 31 vessel classes, the power demand (kW) is calculated for the various inland waterway types and rivers in the Netherlands by means of a model described by Bolt (2003). The main variable parameters within this model that determine the power demand per vessel class are the vessels draught and the speed through water and the stream velocity. The vessels draught is calculated by interpolating between the draught of an unloaded vessel and a fully loaded vessel. The speed per vessel class per geographical water segment was taken from 1 month of AIS-data (July 2015) provided by Pouwels et al. (2017). The average cargo situation (partial load) per vessel class for 1 specific year (2016) was delivered by Statistics Netherlands. The general formula for calculating emissions is as follows:

$$\text{Emissions} = \text{Number} * \text{Power} * \text{Time} * \text{Emission factor}$$

The formula in the box on the next page is used for calculating the emission of substance (s) in one direction (d) specifically for one vessel class (v,c), loaded or unloaded (b), on every distinct route (r) on the Dutch inland waterways. The combination of the number of vessels, their power and their speed is the explanatory variable for emissions. The unit of the explanatory variable for emissions is "kWh". The emission factors are expressed in "kg/kWh", the same unit that is used to express emission standards. The emission factors are dependent on the engine's year of construction. For

calculating the above emission formula, a calculation model has been developed. The calculation protocols and backgrounds of the EMS form the basis of the emission calculations. The complete set of protocols (in Dutch) can be found on the website of the Dutch Emission Registration ([www.emissieregistratie.nl](http://www.emissieregistratie.nl)).

The complete detailed activity data for the calculation as described in formula 1 is only available for the year 2016. For the annual emission calculations of professional shipping the figures are scaled using CBS data on the number of vessel kilometres per vessel class, subdivided to national and international shipping transport, as shown in Figure 5.1. The scaling factors are calculated per CBS ship size class and load. Calculation of emission factors is discussed below. In 2018, the 2016 input data of the BIVAS model of the department of Waterways and Public Works have been used for the detailed distribution of ship types over the waterways. These data have been applied as basis for the calculation of the energy consumption from 2009 onwards (Hulskotte, 2018). For earlier years the original EMS data are still used.

**Emissions from propulsion engines =**  
*the sum of vessel classes, cargo situations, routes and directions of:*  
**{number of vessel passages times**  
**average power used times**  
**average emission factor times**  
**length of route divided by speed}**

or

$$E_{v,c,b,r,s,d} = N_{v,c,b,r,d} \cdot Pb_{v,b,r} \cdot L_r / (V_{v,r,d} + V_r) \cdot EF_{v,s} \cdot CEF_{v,b,r,s} \quad (1)$$

Where:

$E_{v,c,b,r,s,d}$  = Emission per vessel class, (kg)  
 $N_{v,c,b,r,d}$  = Number of vessels of this class on the route and with this cargo situation sailing in this direction  
 $Pb_{v,b,r}$  = Average power of this vessel class on the route (kW)  
 $EF_{v,s}$  = Average emission factor of the engines of this vessel class (kg/kWh)  
 $CEF_{v,b,r,s}$  = Correction factor of the emission factor of this vessel class based on power  
 $L_r$  = Length of the route (km)  
 $V_{v,r}$  = Average speed of the vessel in this class on this route (km/h)  
 $V_r$  = Rate of flow of the water on this route (km/h), (can also be a negative value)

**v,c,b,r,s,d = indices for vessel class, aggregated cargo capacity class, cargo situation, route, substance, and direction of travel, respectively**

In the EMS-protocol for inland shipping, a distinction is made between primary engines and auxiliary engines. Primary engines are intended for propelling the vessel. Auxiliary engines are required for manoeuvring the vessel (bow propeller engines) and generating electricity for the operation of the vessel and the residential compartments (generators). The protocol does not include:

- the emissions of passenger transport, recreational boat transport and fisheries,
- emissions originating from the cargo or sources other than the engines,
- emissions of substances other than those listed above.

The methodology for determining the emission factors for professional inland shipping is described in the EMS protocol for inland shipping (Hulskotte, 2018). Engine emission factors and correction factors on emission factors are contained within the latest version of the protocol.

Tables 5.2 through 5.6 show the implied emission factors for professional inland shipping expressed in grams per kg of fuel for CO, VOC, NO<sub>x</sub> and PM<sub>10</sub>.

The fleet averaged emission factor is determined by a distribution of ship engines over the various year of construction classes to which emission factors have been linked. This distribution is calculated by means of a Weibull function. The general formula of the Weibull function is the following:

$$f(x; k, \lambda) = \frac{k}{\lambda} \left(\frac{x}{\lambda}\right)^{k-1} e^{-(x/\lambda)^k}$$

The median age (the age when 50% has been replaced) can be calculated through the formula:

$$\lambda \ln(2)^{1/k}$$

**Figure 5.1**

Methodology for scaling the 2016 data to derive activity data and emissions for other years of the time series

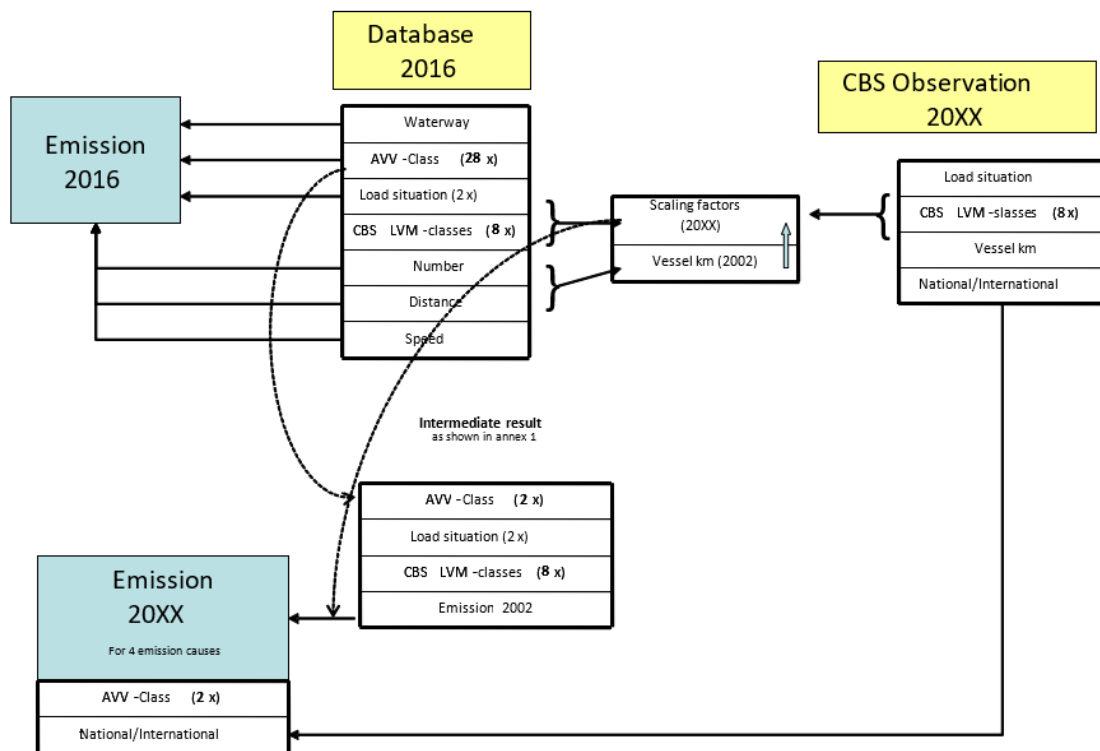

In 2017 a new desk research into the age of vessel engines was completed. From the results it appeared that the age whereby engines are replaced is higher than previously estimated. Tabel 5.2 shows the new engine replacement functions for three load capacity classes together with the previously used engine replacement function. The median engine replacement age was previously estimated at 9.6 years but is currently estimated at about 15 years depending on the load capacity class. After 30 years after new built installation about 15% to 20% of the engines is still used. With the previous model parameters only 7.5% of the engine still was in use after 30 years. The engine data were based on a selection of the IVR vessel database (Wijnbelt 2014). Only vessels that had an MMSI number were taken into account because it can be assumed that that these vessels were still

in use. The result of the model were compared to the results of questionnaire among 305 professional shipowners (BLN Schuttevaer, 2017). The results could explain the answer about engine replacement rather well.

**Table 5A**  
Weibull parameters on behalf of engine replacement function and median life

Engine replacement profile	Lambda_i	Kappa_i	Median engine replacement age (year)
L1	20.4	1.30	15.4
L2	18.5	1.12	13.4
L3	18.6	1.26	13.9

**Figure 5.2**  
Engine replacement functions applied to determine park weighed emission factors

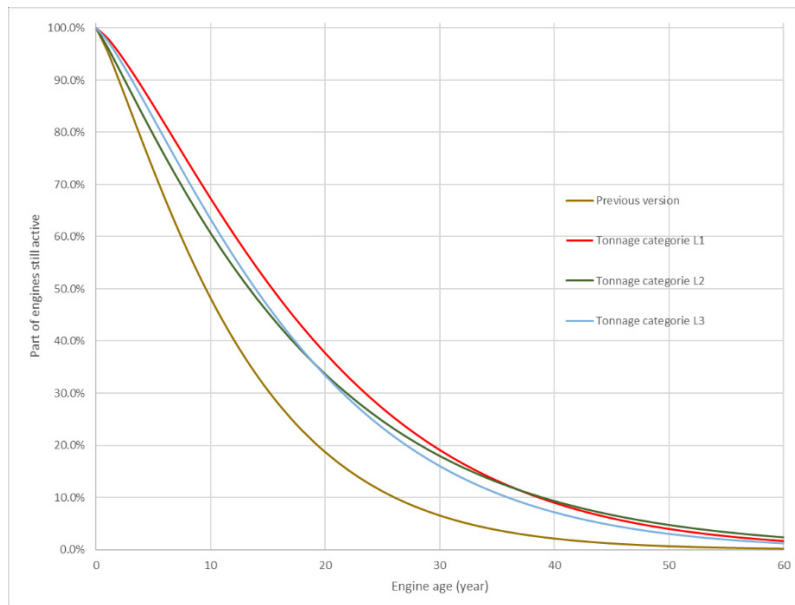

**Emission factors for the combustion of motor fuels; SO<sub>2</sub> and heavy metals**

The emission factors for SO<sub>2</sub> and heavy metals have been derived from the sulphur and heavy metal content of the motor fuels. The sulfur content is shown in table 13 of the EMS protocol for inland shipping (Hulskotte & Bolt 2012). The metal content of diesel is shown in Table 5.6. PM<sub>2,5</sub> emissions are calculated from PM<sub>10</sub> by using an emission profile (see Table 5.8). The calculation of the combustion emissions of VOC and PAH components, including methane, also takes place using profiles. First the combustion emissions of VOC are calculated. The profiles indicate the fractions of the various VOC and PAH components in total VOC. By multiplying total VOC emissions with the fractions from these profiles, the emissions of individual VOC and PAH components are estimated. The emissions of heavy metals are calculated by multiplying the fuel consumption with the emission factors that are based on the metal content of the marine fuels. The emission factors, expressed in grams per kg of fuel, are shown in Table 5.6. The emission profiles for VOC and PAH components are shown in Table 5.7.



## 5.2.2 Passenger ships and recreational craft

For recreational craft, the emissions are calculated by multiplying the number of recreational boats (allocated to open motor boats/cabin motor boats and open sailboats/cabin sailboats) with the average fuel consumption per boat type times the emission factor per substance, expressed in emission per engine type per quantity of fuel. The various types of boats are equipped with a specific allocation of engine types that determine the level of the emission factors. The emission factors are measured in quantities of emission per quantity of generated kinetic energy. By dividing them with the specific fuel consumption (fuel quantity required per unit of generated kinetic energy), an emission factor per quantity of fuel is obtained. The implied emission factors for recreation craft (in grams/kg fuel) are also shown in *Tables 5.2 through 5.6*. The methodology for calculating emissions to water from recreation craft is described in *Deltares & TNO (2016)*.

There is no recent data on the number of passenger ships or the energy use by passenger ships in the Netherlands, therefore the fuel consumption figures for 1995 are applied for all years afterwards.

## 5.2.3 De-gassing cargo fumes to the atmosphere

The calculation of the emissions resulting from de-gassing of cargo fumes are conducted for each substance using the following formula:

**Weight of VOC (vapour) emitted =  
mass of unloaded cargo (A) \* percentage after which the hold is ventilated (B) \* evaporation  
factor (C)**

The required data fall into three categories:

- Transport data, originating from statistical information;
- Data about the practice of loading and unloading (also linked partially to regulations);
- Chemical and physical data, originating from the relevant literature.

In this formula, the weight of the unloaded cargo is the explanatory variable for emissions. The emission factor is arrived at by multiplying the evaporation factor with the percentage of the unloaded cargo after which the hold is ventilated. A comprehensive description of the methodology can be found in the protocol established as part of the EMS project (Bolt 2003), or more recently in De Buck et al. (2013). Emission factors for the calculation of cargo fumes references are made to the protocol on this subject, drawn up within the framework of the EMS project ( Bolt, 2003) and which was updated by the Buck et al. (2013). The resulting fuel consumption for inland navigation is shown in *Table 5.1*.

Recently an extension on this method for non-classified travels has been introduced. Non-classified travels are travels in which a ship is registered for degassing only once, or in cases only one successive travel is registered after degassing.

The degassing emissions of these non-classified travels are now calculated with an average (implied) emissionfactors from classified travels (Hulskotte 2019).

## 5.3 Uncertainties

In 2016, an expert workshop was organized with the members of the Task Force Transportation in the Dutch PRTR to discuss and estimate the uncertainties in the activity data and emission factors used for the emission calculations for the transport sector. Uncertainties were estimated at the level of the NFR source categories. The setup and outcomes of the workshop are described in Dellaert & Dröge (2017). The report also compares the estimates resulting from the workshop to estimates reported by other countries and default estimates from the Emission inventory guidebook. The resulting uncertainty estimates for inland navigation are provided in table 5B.

The activity data for inland navigation is deemed to be rather uncertain, especially for recreational craft and for evaporation and degassing. Activity data for commercial inland shipping is derived from Statistics Netherlands, using monitoring data. Since the busiest rivers are not fully covered in these monitoring data, uncertainty is deemed rather large. Uncertainty in emission factors is deemed to be smallest for NO<sub>x</sub>, as some measurements have been performed in recent years. Uncertainty for other components is deemed to be high given the lack of (recent) measurement data.

**Table 5B**

Uncertainty estimates for inland navigation and recreational craft (Dellaert &amp; Dröge 2017)

NFR	Type	Fuel type	Uncertainty activity data	Uncertainty implied emission factors				
				NO <sub>x</sub>	SO <sub>x</sub>	NH <sub>3</sub>	PM <sub>10</sub> /P M <sub>2.5</sub>	NMVOC
1A3di(ii)	Inland, international	Diesel	50%	35%	20%	500%	50%	100%
1A3dii	Inland, national	Diesel	50%	35%	20%	500%	50%	100%
1A3dii	Passenger and ferryboats	Diesel	100%	50%	20%	500%	100%	200%
1A5b	Recreational shipping, exhaust gases	Petrol	200%	50%	20%	100%	100%	50%
1A5b	Recreational shipping, exhaust gases	Diesel	200%					100%
1A5b	Recreational shipping, petrol evaporation		100%					200%
2D3i	Inland shipping, degassing cargo		100%					100%

## 5.4 Points for improvement

The fuel consumption estimates of passenger boats and ferries have not been updated since 1994 and should be re-evaluated. The reliability of the data concerning the number of recreational boats and the number of hours of their usage on the waterways is low.

### **Weak points of engine emissions in professional inland waterway shipping**

The amount of vessel movements on the rivers Waal and IJssel in particular should be improved.

### **Weak points concerning cargo fumes emissions**

Important uncertainties are the following:

- What is the subdivision according to individual substances within the “not named elsewhere” classes, or remainder categories?

- What is the percentage of loading cycles with a compatible substance where degassing is actually avoided because a vapour processing facility is available and is being used?
- What percentage of the loading does not take place directly onshore?
- Which saturation factor must be used for emptied tanks, and how large are the cargo residues that can still evaporate?

***Most important points of improvement for motor emissions in professional inland shipping***

It is recommended to implement the annual derivation of the table with shipping movements by using AIS data. The stability and completeness of AIS-data has to be tested at least for one or two years instead of one month only like in Pouwels et al. (2017). In 2021 first analyses of AIS data were performed and in 2022 next steps will be taken for implementation of this methodology.

Besides more reliable emission factors, there should be harmonization with the calculation method that is used for VOC emissions in industry. The emissions must be consistent and it must be clear which emissions are attributed to shipping and which are attributed to industry. The calculation proposed here makes a distinction between different sequential cargoes, which is an important piece of information not only when determining emissions, but also the effects of policy measures.

# 6 Fisheries

## 6.1 Source category description

Fisheries covers emissions from fishing activities in the Netherlands, including inland fishing, coastal fishing and deep-sea fishing. Diesel engines are used to propel fishing vessels such as deep-sea trawlers and cutters, and to generate electrical power on-board of fishing vessels. These diesel engines can be fuelled with either diesel oil (distillate) or residual fuel oil. Emissions of air pollutants from fishing are reported under source category 'Fishing' (1A4ciii) in the NFR. This includes emissions resulting from all fuel supplied to commercial fishing activities in the Netherlands. For air quality modelling purposes, emissions of air pollutants from fishing activities on Dutch national territory, including the Dutch Continental Shelf, are estimated separately.

## 6.2 Activity data and (implied) emission factors

Two methodologies based on AIS-data are applied from 2016 onwards to calculate emissions on Dutch national waters. For deep-sea trawlers the same methodology is applied as used for maritime navigation (see Chapter 7) because essentially no fishing activities are performed on Dutch national territory, including the Dutch Continental Shelf. On Dutch territory these vessels are sailing towards and from their fishing grounds. As such, the speed based AIS approach that is used to estimate fuel consumption and resulting emissions from maritime navigation on the Dutch part of de North Sea is deemed applicable.

For other fishing vessel categories (rather small vessels, mostly cutters) a different methodology is used, since these vessels are actually fishing on Dutch national waters. As such, low sailing speeds are associated with high energy use, contrary to maritime navigation where low sailing speeds result in low energy use. The methodology used for these fishing vessels is described in detail in Hulskotte and Ter Brake (2017). It is essentially a energy based method whereby energy-rates of fishing vessels are split up by activity (sailing and fishing) with a distinction in available power of propulsion engine(s). For each fishery segment (combination of gear or catch method combined with power category) a fuel rate (kilogram/hour) for sailing or fishing was assessed by Turenhout et al. (2016). The distinction for each fishery segment between sailing and fishing is based on the actual speed of the fishing vessels as taken from AIS-data. The emission factors of small vessels (other than deep-sea trawlers) are assumed to be equal to emission factors of inland navigation because the engine types that are applied in these vessels are essentially the same. The year of build of the engines of (Dutch and former Dutch) fishing ships was derived from Shipdata (<http://www.shipdata.nl>) to help estimate the emission factors. Part of this data concerned the engine type and model and the year of build. Data were enriched with engine changes when indicated on the website <http://www.kotterfoto.nl> and data of foreign fishing ships (including installing data of new engines) were added from the [FIGIS](#)-database managed by FAO.

For calculation of emission factors of other years before 2016 (where no fleet data are available) values for  $\kappa$  and  $\lambda$  have been determined to be 2.3 and 1.3. A median engine age of 18 year is inferred from the data of the fishing fleet. These data are used to calculate the fraction of engines for each age class in a every year before 2016. The emission factors of deep-sea trawlers before

2016 were taken from the implied emission factors of seagoing vessels (Table 7.2 to 7.8). The resulting emission factors for fishery for Dutch territory are shown in Table 6.2. For the calculation of PCB, HCB and Dioxins emissions the same factors were used as for maritime navigation, see paragraph 7.2.3.

Activity data for the years 1990 to 2015 was based on fixed shares of total fuel consumption by deep sea trawlers and cutters as reported by CBS. The share of each fuel was calculated by using data from 2016 where both the fuel usage on the Netherlands territory as inferred. Emissions from different VOC and PAH components are calculated using the species profiles as were used for inland navigation, as in Tables 5.7A and 5.7B. The resulting fuel consumption of fisheries on Dutch territory is presented in Table 6.1.

**Table 6A**  
Allocation of fuel sold to source categories within fisheries

From national fuel statistics (CBS)	Diesel		Heavy Fuel oil
Allocation to	Diesel	MDO	HFO
Exhaust gas, foreign sea shore fisheries	5.41%		
Exhaust gas, national inland and sea shore fisheries	22.39%		
Exhaust gas, national deep sea fisheries	1.92% (at berth)	0.76%	26.68%

For international reporting, fisheries emissions should reflect all fuel sold to fisheries in the Netherlands. As such, the AIS based approach described above is used to estimate implied emission factors for diesel oil and heavy fuel oil, which are subsequently combined with fuel sales data to fisheries from the Energy Balance to derive fuel sold based emission data for fisheries. The fuel sales data and implied emission factors are shown in Table 6.3.

## 6.3 Uncertainties

In 2016, an expert workshop was organized with the members of the Task Force Transportation in the Dutch PRTR to discuss and estimate the uncertainties in the activity data and emission factors used for the emission calculations for the transport sector. Uncertainties were estimated at the level of the NFR source categories. The setup and outcomes of the workshop are described in Dellaert & Dröge (2017). The report also compares the estimates resulting from the workshop to estimates reported by other countries and default estimates from the Emission inventory guidebook. The resulting uncertainty estimates for national fishing are provided in table 6B. Note that the uncertainty in the activity data for fisheries applies to the bottom-up approach using AIS data, and does not apply to the top down approach which uses the fuel sales from the energy statistics to estimate the activity data. Uncertainty in fuel sales data is estimated to be 5%, as shown in Table 2.5. The top down approach is used for the reporting of emissions for the National Emission Ceilings Directive (NECD).

**Table 6B**  
Uncertainty estimates for national fishing (Dellaert & Dröge 2017)

Type	Fuel	Uncertainty activity data	Uncertainty implied emission factors
------	------	---------------------------	--------------------------------------

			NO <sub>x</sub>	SO <sub>x</sub>	NH <sub>3</sub>	PM <sub>10</sub>	PM <sub>2.5</sub>	EC
<b>Fisheries</b>	Diesel	15%	30%	20%	50%	50%	50%	100%

Uncertainty in AIS activity data is deemed rather small, since all vessels are equipped with AIS transponders. Uncertainty estimates for emission factors were estimated based on uncertainty estimates for inland and maritime navigation.

## 6.4 Points for improvement

No measurement data on emissions of fishing vessels are available. As such, emission factors have been derived from inland and maritime navigation. Measurement of emission factors of the most important fishing vessel categories during various operational conditions could improve estimation of emissions.

# 7 Maritime navigation

## 7.1 Source category description

Maritime navigation includes emissions from seagoing ships in the Netherlands and on the Dutch part of the Continental Shelf. Emissions result from the use of fuel in the main engines of the ships and in auxiliary engines. The main engines are used for propelling the vessel. Auxiliary engines are required for manoeuvring (bow propeller engines) and generating electricity for operations such as loading and unloading and housing workers or passengers (in the case of ferryboats). Generating electricity in harbours takes place using diesel engines and, in the case of large seagoing vessels, also boilers.

The propulsion of seagoing vessels on routes within the national continental shelf, other route-linked shipping channels on Dutch territory and generating electricity in harbours takes place primarily with the aid of diesel engines. Other engines using fossil fuels, which are seldom applied, are gas turbines and steam engines. The combustion processes that take place in these engines cause emissions of air pollutants.

The most important substances released are NO<sub>x</sub>, particulate matter, CO, VOC and SO<sub>2</sub>. CO<sub>2</sub> and SO<sub>2</sub> are caused by the oxidation of the carbon and sulphur present in the fuel through combustion. Emissions of these substances are therefore completely dependent on the contents of carbon and sulphur in the fuel and the quantity of fuel that is combusted. Nitrogen oxides (NO<sub>x</sub>) are primarily caused by the high temperatures and pressures in combustion engines, which cause the nitrogen present in the atmosphere to combine with oxygen. CO, VOC and PM<sub>10</sub> are products of incomplete combustion. The emissions of the latter substances therefore depend primarily on the technological properties of the engines and the way in which these engines are used. PM<sub>10</sub> emissions are also correlated with the sulphur content of the fuels used.

Emissions of air pollutants from maritime shipping in the Netherlands are reported under Source category 'International maritime navigation' (1A3di(i)) in the NFR. This includes emissions from all maritime shipping on Dutch territorial waters, excluding fishing which is reported separately in the

inventory. Emissions from international maritime shipping are not included in the national emission totals but are reported as a memorandum item.

## 7.2 Activity data and (implied) emission factors

The methodology for calculating exhaust emissions from maritime navigation in the Netherlands was originally developed in 2003 in the framework of the so-called EMS-project (Emission Monitoring Shipping). This methodology is described in detail in protocols, which are available at the website of the [E-PRTR](#). Activity data for the methodology were derived from Statistics Netherlands (number of visiting ships per harbour per year) and from Lloyds Fairplay (vessels movements on the Dutch part of the North Sea). This methodology is applied for the 1990-2007 period of the time series.

Since 2008, fuel consumption and the resulting emissions of air pollutants by maritime shipping on the Netherlands Continental Shelf, the 12-mile zone and the port areas in the Netherlands are calculated annually by MARIN and TNO (MARIN 2018 and earlier editions, available at the website of the [E-PRTR](#)). Data on ship movements are derived from AIS transponders. Since 2005 all trading vessels larger than 300 GT are equipped with an Automatic Identification System (AIS). AIS systems transmit ship information such as destination, position, speed and course. Statistical information such as the name of the ship, the IMO number, ship type, size, destination, and draught are transmitted every 6 minutes. Dynamic information such as position, speed and course are transmitted every 2 to 6 seconds. The AIS data for ship movements on Dutch territorial waters are derived annually from the Netherlands Coastguard. The methodology to derive fuel consumption and emissions from the activity data is described below. The methodology distinguishes between ships at sea, ships manoeuvring in harbours and ships at berth.

### 7.2.1 Emissions of sailing sea-ships

The calculation method for sailing vessels based on AIS data, is uniform for all distinguished areas and all sailing speeds. The calculation is performed by multiplying emission factors derived per individual vessel by the covered distance of the specific vessels on Dutch territorial waters (formula 1).

$EM_{v,g,s,m}$	=	$\sum_i (EF_{v,g,s,m,i,t} \cdot D_{i,a,t})$	(1)
Where:			
$EM_{v,g,s,m,t}$	=	Emission of substance per vessel type v, size class g, engine type m in area a at point in time t, (kg)	
$EF_{v,g,s,m,i,t}$	=	Emission factor substance (s), individual vessel i with vessel type v and size class g and engine type m, point in time t, kg/mile	
$D_{i,a,t}$	=	Covered distance vessel I in area a	
i,v,g,a,m,s,t	=	Respective index for vessel, vessel type, size class, area, engine type, substance, point of time	

In order to determine the distance covered, the vessel speed and position is derived from the AIS data every two minutes for each vessel. Before AIS-data became available, the distance covered by



various ships in Dutch national waters was derived from vessel movement records of Lloyds Fairplay and the SAMSON route network.

For vessels with only one main engine, it is assumed that 85% of the maximum continuous rating power (MCR) of the engine is required for the vessel to attain its design speed. This assumption originally was based on an inquiry in the Port of Rotterdam under 89 vessels, which resulted in an average value of 83%. The latest used Lloyds database (IHS, 2018) gives total engine power (powerkwmax) and power to attain the service speed (powerkwservice) for about 26.000 vessels. For the majority of this vessels (about 80%) the value of powerkwservice/powerkwmax is exactly 85% and for about 7% of the vessels the value of powerkwservice/powerkwmax is exactly 90%, as is shown in Figure 7.1.

At speeds around the design speed, the emissions are directly proportional to the engine’s fuel consumption. At lower operating speeds, less engine power is required. In these low load conditions, the engine runs less efficiently. This leads to an increase in emissions compared to the normal operating conditions. The emission factors are adjusted accordingly, using Formula 2. The emission factors are corrected for the engine power that is assumed to be required for the observed vessel speed (CRS). At the same time the emission factors are corrected whenever the engines produce less power (CEF).

**Figure 7.1**  
Share of vessels that attain the service speed at a certain fraction of total propulsive engine power

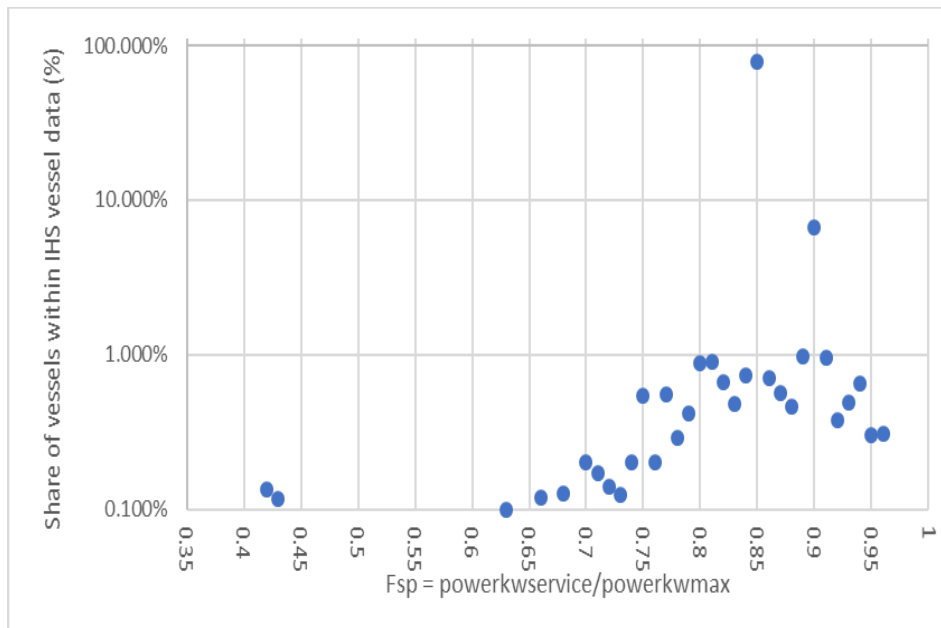

$EF_{v,g,s,m,i,t}$	=	$EF_{v,g,s,m,i} \cdot CRS_{i,t} \cdot CEF_{p,s}$	(2)
Where:			
$EF_{v,g,s,m,i,t}$	=	Emission factor substance (s), individual vessel i with vessel type v and size class g and engine type m, point in time t, (kg/mile)	
$EF_{v,g,s,m,i}$	=	Emission factor substance (s), individual vessel i with vessel type v and size class g and engine type m, not corrected at 85% power, (kg/mile)	
$CRS_{i,t}$	=	Correction factor for vessel power i At point of time t, (./.)	
$CEF_{p,s}$	=	Correction factor per substance dependent on the power as %MCR, (./.)	

Depending on the engine, specific load correction factors specified per substance can be derived from the EMS protocols. The correction factors applied in the emission calculations for the year 2011 were extended by distinction of different engine types. In order to get more accurate calculations three engine groups were discerned: reciprocating engines, steam turbines and gas turbines. The correction factors (CEF) in formula 2 are shown in *Tables 7.11A-7.11C*. The list was extended by some values provided in the documentation of the EXTREMIS model (Chiffi et al. 2007). The correction factors at MCR over 85% are assumed to be 1. The emission factor corrections exclusively apply to the emissions factors for main engines and not to the emission factors for auxiliary engines, which are derived separately from the vessel data.

Since steam turbines are predominantly used by LNG-carriers, two types of fuels were assumed to be consumed: Boil-off Gas (BOG) and heavy fuel oil (HFO). It was assumed that at lower engine loads (below 30%) engines are mainly operated on HFO. This is expressed in the correction factors for SO<sub>2</sub> and CO<sub>2</sub> (see *Table 7.11B*). On higher loads (above 30%) the average fuel mixture between BOG and HFO is assumed, as derived from (Grose & Flaherty 2007). The correction factors from steam turbines were derived from the EXTREMIS model (Chiffi et al. 2007). Correction factors for gas turbines were estimated with data from the ICAO Aircraft Engine Emissions Databank (UK Civil Aviation Authority 2010). The emission behaviour of the GE CF6-6D (marine derivative: GE LM2500) and the Allison 501 (AN 501) was taken as representative for the two most occurring gas turbines in marine applications (see *Table 7.11C*).

Formula (3) applies for correcting the power of propulsion engines (CRS). In a 2018 study to validate fuel consumption calculated with the model it was advised to apply the power 3.2 instead of 3 based on MARIN ship trials (Schouten & Hasselaar 2018). In formula 3 it is taken into account that the fuel consumption of the main engines during very slow manoeuvring will not drop significantly below 10% of the consumption at service speed. With formula 3 the minimal power of main engines has been limited at 8% (=0.85 x 0.1/1.1) reflecting cumulative internal friction losses (engine and other moving parts). Together with the correction factor (CEF = 1.2) a fuel consumption of little less than 10% of the design speed will be attained. At a value of 1.176 of CRS 100% of MCR is exceeded. This is the case with an exceedance of 106% of the service speed. In the calculations 100% MCR is used as maximum value.

$CRS_{i,t}$	=	$[(V_{i,t,actual}/V_{i,service})^{3.2} + 0.1] / 1.1$	(3)
Where:			
$CRS_{i,t}$	=	Correction factor vessel power i At point of time t, (./.)	
$V_{i,t}$	=	Vessel speed i at point of time t, (knots)	
$V_{i,service}$	=	Service speed of vessel i, (knots)	
$i,t$	=	resp. index for vessel and point of time	

## 7.2.2 Emissions from seagoing vessels at berth

Fuel consumption by seagoing vessels at berth is calculated by multiplying the time at anchor of visiting vessels, derived from AIS data, by their fuel consumption per unit of time, as determined in two TNO-studies (Hulskotte et al. 2013 & Hulskotte & Matthias 2013). The calculation method developed in the EMS protocol (see formulas 4, 5 and 6) is still being used, with exception of the period at anchor and the anchor location, which are determined using AIS data. For years 2007 and earlier, no AIS data are available, so the number of ships at anchor were derived from Statistics Netherlands, which reported the annual number of visiting ships per harbour, including vessels types and GT. The average time at anchor based on estimates, as described in Appendix 1 of the EMS protocol.

In the first step of the emission calculation, total fuel consumption is derived based on the size of the vessel, the time at anchor and the specific fuel consumption rate, as is shown in the box below (formula 4).

$F_v$	=	$V_v \cdot T_v \cdot E_v$	(4)
Where:			
$F_v$	=	Fuel consumption, (kg)	
$V_v$	=	Vessel size (GT)	
$T_v$	=	Time at anchor (hours/visit)	
$E_v$	=	Rate of fuel consumption (kg/GT.hour)	
$v$	=	index for type of vessel	

In a second calculation step, total fuel consumption is specified according to fuel type and engine type/boilers (formula 5).

$$F_{v,f,m} = f_{v,f} \cdot f_{v,m} \cdot F_v \quad (5)$$

Where

$F_{v,f,m}$  = Fuel consumption per vessel type (v), per fuel(f) and engine type (m),(kg)

$F_v$  = Fuel consumption per vessel type, (kg)

$f_{v,f}$  = Fraction of fuel (f) per vessel type (v), (./.)

$f_{v,m}$  = Fraction of engines (m) per vessel type (v) (./.)

v,f,m = index for vessel type, fuel, engine type, respectively

The emissions of air pollutants are subsequently calculated by multiplying (Formula 6) with the emission factors per engine type and fuel type by the fuel consumption as derived from Formula (5).

$$EM_{s,v,f,m} = F_{v,f,m} \cdot \text{Emission factors}_{f,m} \quad (6)$$

Where:

$EM_{s,v,f,m}$  = Emissions (kg)

$F_{v,f,m}$  = Fuel consumption per vessel type (v), per fuel (f) and engine type (m),(kg)

Emission factors<sub>f,m</sub> = Emission factor per substance (s) fuel (f) and engine type (m), (kg/kg)

v,f,m,s = index for vessel type, fuel, engine type, substance

The accompanying set of tables contains further information on total fuel use over fuel types in dependence of ship types, the allocation of fuel amount over engine types and apparatus during berth, and the emission factors used (tables 7.10A – 7.10G). The resulting fuel consumption for ships at anchor, manoeuvring in ports and sailing on the Dutch part of the Continental Shelf is shown in Table 7.1. Tables 7.2-7.5 show the resulting emissions of CO, VOC, NO<sub>x</sub> and PM<sub>10</sub>. PM<sub>2,5</sub> emissions are calculated as a fraction of PM<sub>10</sub> emissions. Table 7.9 shows the assumed share of PM<sub>2,5</sub> in the PM<sub>10</sub>-emissions.

### Use of shore power

The use of shore power reduces the fuel consumption of auxiliary engines at berth. Therefore using shore power only effects emissions of auxiliary engines. At berth ships also use other engines such as boilers, causing the emission reduction effects to differ for different pollutants.

The effect of using shore power use is calculated for four Ferries that maintain a regular ferry service between the Netherlands and the UK (Harwich – Hoek van Holland). For these ships, a shore power installation was installed during mid 2012.

mmsi	Ship name	EMStype_upd_IHS	size	hours_at_berth	x_grid	y_grid	Connectionfactor
244513000	Stena Transit	6	6	1882,8	137	886	90%
246762000	Stena Transporter	6	6	2052,3	138	886	90%
235080274	Stena Britannica	6	7	2188,8	137	886	90%
244758000	Stena Hollandica	6	7	1688,8	137	886	90%

The number of hours that these four ferries are annually berthed at the Ferry terminal at the Hook of Holland is determined using AIS data on the presence of these four vessels at berth. The data is obtained from MARIN. *Table 7.10G* shows the activity data that is input for the calculation of the total of shore power use. This implicitly assumes that shore power is always used in case these ferries are berthed. For the actual use of Shore Power it is assumed that in 90% of the hours at berth, shore power is connected and used, the other 10% of time is used for maneuvering, berthing and shore power (dis)connecting. For 2012, the year in which the shore power facility was put into use, half the number of hours is used.

[Emission reduction shore power] = [Emissionfactor\_kg\_per\_hour\_AE\_Berth]\*[hours]\*0,9 ; (kg)

The effect on the use of MGO\_ulmf is calculated as follows:

[Reduced energy demand] = [Emission reduction shore power (CO<sub>2</sub>)] \* 0,9 / [EF\_AE (CO<sub>2</sub>)] \* 1000000/3,6; (TJ) = (kg)/(g/kWh)\*1000000/3,6

### 7.2.3 Exhaust emissions of SO<sub>2</sub>, N<sub>2</sub>O, NH<sub>3</sub>, heavy metals and VOC/PAH components

Since January 1<sup>st</sup> 2010 the sulphur content of marine fuels used for ships at berth in the EU is regulated to a maximum of 0.1 percent. This implies that only marine gas oil with a sulphur content below 0.1 percent is used in harbours. The specification of fuel types at berth is adapted according to this new regulation. In tanker ships a reduction factor (50% for PM and 90% for SO<sub>2</sub>) is applied to the emission factors for boilers, because gas scrubbers are often applied in order to protect ship internal spaces from corrosion by inert gases produced by boilers.

Sulphur content from ships at the North Sea is also regulated. In 2007, the North Sea was designated as sulphur oxide emission control area (SECA). The sulphur limit for the fuels used on the North Sea decreased from 1.5% in 2007 to 1% in 2010. This is taken into account in the emission calculation. From 2015 onwards, the sulphur limit is set at 0.1%. By lack of enforcement observations a compliance rate of 50% was assumed on the Netherlands Continental Shelf (NCS) for 2015. This was increased to 90% for 2016. The compliance rates for at berth and moving In Dutch harbour areas were assumed to be 90% and 100% respectively in both 2015 and 2016. The SO<sub>2</sub> emission factors for diesel oil and heavy fuel oil used at anchor and while sailing are shown in *Table 7.6*.

The emissions on Dutch territory of N<sub>2</sub>O and NH<sub>3</sub> are calculated by using default emission factors for N<sub>2</sub>O (IPCC 2006) and NH<sub>3</sub> (Ntziachristos and Samaras, 2000), as shown in *Table 7.7*. These emission factors have been multiplied by the total fuel consumption of seagoing ships on Dutch territory as calculated using the methodology described above. The emissions of heavy metals are calculated by multiplying the fuel consumption with the emission factors that are based on the metal content of the marine fuels. The emission factors, expressed in grams per kilogram of fuel, are shown in *Table 7.7*.

The calculation of the combustion emissions of VOC and PAH components, including methane, takes place using species profiles. The VOC and PAH profiles have been ascertained by VROM (1993), see *Tables 7.8A, B and C*. First, as discussed above, the combustion emissions of VOC are calculated. The species profiles subsequently indicate the fractions of the various VOC and PAH

components in total VOC. By multiplying total VOC emissions with the fractions from these profiles, the emissions of individual VOC and PAH components are estimated.

Three substances (PCB, HCB and Dioxins) were added to the emissions of international marine navigation: 1.A.3.d.i(i), see *Table 7.8B*. The emission factors applied were directly copied from the EMEP/EEA air pollutant emission inventory guidebook 2019 – Update Oct. 2020.

Substance	Unit	Marine diesel oil/marine gas oil (MDO, MGO_ULMF)	Bunker fuel oil (HFO)	Reference
PCB	mg/ton fuel	0.038	0.57	Cooper, 2005
HCB	mg/ton fuel	0.08	0.14	Cooper, 2005
PCDD/F	µg I-TEQ/ton fuel	0.13	0.47	Cooper, 2005

The values of the emission factors used might not be representative anymore because several measures have altered current fuel quality. More recent data are not available, though.

## 7.3 Uncertainties

In 2016, an expert workshop was organized with the members of the Task Force Transportation in the Dutch PRTR to discuss and estimate the uncertainties in the activity data and emission factors used for the emission calculations for the transport sector. Uncertainties were estimated at the level of the NFR source categories. The setup and outcomes of the workshop are described in Dellaert & Dröge (2017). The report also compares the estimates resulting from the workshop to estimates reported by other countries and default estimates from the Emission inventory guidebook. The resulting uncertainty estimates for maritime navigation are provided in table 7A.

Uncertainty in activity data, i.e. AIS based calculation of fuel consumption on Dutch territorial waters, was estimated at 20% for HFO and MDO and 50% for LNG. LNG use for maritime navigation is small and empirical data is limited, as such, uncertainties for LNG are larger. Fuel consumption when moored is also rather uncertain since empirical data is limited. Emission factors are rather uncertain due to a lack of (recent) measurements. This holds specifically for NH<sub>3</sub>, EC and NMVOC.

**Table 7A**  
Uncertainty estimates for maritime navigation (Dellaert & Dröge 2017)

NFR	Type	Fuel	Uncertainty activity data	Uncertainty implied emission factors					
				NO <sub>x</sub>	SO <sub>x</sub>	NH <sub>3</sub>	PM <sub>10</sub>	PM <sub>2.5</sub>	NMVOC
1A3di(i)	Anchored NCP	HFO	20%	50%	50%	500%	50%	50%	200%
1A3di(i)	Anchored NCP	MDO	20%	50%	50%	500%	50%	50%	200%
1A3di(i)	Sailing NCP	HFO	20%	50%	50%	500%	50%	50%	200%
1A3di(i)	Sailing NCP	LNG	50%	100%	100%			100%	

<b>1A3di(i)</b>	Sailing NCP	MDO	20%	50%	50%	500%	50%	50%	200%
<b>1A3di(i)</b>	Moored NL		50%	50%	50%	500%	50%	50%	200%
<b>1A3di(i)</b>	Sailing NL	HFO	20%	50%	50%	500%	50%	50%	200%
<b>1A3di(i)</b>	Sailing NL	LNG	50%	100%	100%			100%	
<b>1A3di(i)</b>	Sailing NL	MDO	20%	50%	50%	500%	50%	50%	200%

## 7.4 Points for improvement

The emission calculation for maritime navigation could be improved regarding:

- The fuel consumption of vessels at anchor is not linear to the size of the vessels. The determination of non-linear correlations between the vessel size and fuel consumption could lead to an improvement of the results.
- Implementing measurements in practice concerning particulate matter emissions from seagoing vessels that burn heavy fuel oil.
- Determine the possibility of conducting a systematic data collection on the sulphur content of fuels. To know the extent of the uphold of IMO Annex VI is an important parameter in the calculation of SO<sub>2</sub> and PM emissions.
- Determine the possibility of conducting a systematic data collection on the sulphur content of fuels.
- More detailed data on the use of shore power from the Stena Line ferries

# 8 Civil aviation

## 8.1 Source category description

Civil aviation includes all emissions from national and international civil aviation in the Netherlands. This includes emissions from both scheduled and charter flights, passenger and freight transport, air taxiing, helicopter flights and general aviation. Emissions from civil aviation result from the combustion of jet fuel (jet kerosene) and aviation gasoline. Most civil aviation in the Netherlands stems from Amsterdam Airport Schiphol, which is by far the largest airport in the country, although some regional airports have grown rather quickly since 2005. The other airports besides Schiphol can be classified as follows:

- Regional airports: Maastricht, Eindhoven, Rotterdam, Lelystad and Groningen
- Small airfields: Twente, Ameland, Budel, Den Helder, Hilversum, Hoogeveen, Midden-Zeeland, Noordoostpolder, Oostwold, Seppe, Teuge, Texel and Drachten.

Emissions of air pollutants from civil aviation in the Netherlands are reported under Source category 1A3ai(i) (International aviation LTO (civil)) in the NFR, as is shown in Table 8A. This includes emissions during the Landing and Take-Off Cycles (LTO-cycle) from all departures and arrivals in the Netherlands from both national and international aviation. It also includes particulate matter emissions from tyre and brake wear, and emissions from auxiliary power units (APU). Emissions from the storage and transfer of jet fuel are calculated for Amsterdam Airport Schiphol and the regional airports. Emissions from ground support equipment (GSE) at Schiphol and the regional airports are included in source category *Other, mobile* (1A5b). Cruise emissions of air pollutants of domestic and international aviation (i.e. all emissions occurring above 3000 ft.) are not part of the national totals and are currently not estimated. LTO-emissions from domestic civil aviation are reported separately under Domestic Aviation LTO (1A3aii(i)). Table 8.7 shows which substances and emission processes are estimated for which airports.

In the past, rough estimates have been made of the air pollutant emissions from military aviation during the landing and take-off cycle (LTO). As the Ministry of Defence is not allowed to provide detailed figures concerning military aircraft movements, an update of the emissions from military aircraft is not possible. As the current emission figures almost certainly differ a lot from the emissions estimated in the past, it has been decided to discontinue the estimation and publication of military emissions during the LTO cycles in the Dutch Emission Inventory.

**Table 8A**  
Emission reporting for civil aviation in the CRF and NFR

NFR-code	Source category	Flight stage	Reported under
1A3ai(i)	International aviation LTO (civil)	LTO only	National emission totals
1A3aii(i)	Domestic aviation LTO (civil)	LTO only	National emission totals



## 8.2 Activity data and (implied) emission factors

The emission calculations for civil aviation are performed with the CLEO model created by TNO. The model uses activity data and emission factors to calculate the emissions of civil aviation from the various sources described above. The emission calculations for the individual sources are explained below. A more detailed description of the CLEO model is available in Dellaert & Hulskotte (2017).

### 8.2.1 Exhaust emissions at Amsterdam Airport Schiphol

The exhaust emissions of CO, VOC, NO<sub>x</sub>, PM<sub>10</sub>, PM<sub>2.5</sub>, EC, SO<sub>2</sub>, CO<sub>2</sub> and lead caused by civil aviation during the LTO are calculated annually using a flight-based Tier-3 methodology. The methodology is derived from the widely used method of the US Environmental Protection Agency (EPA), which was later applied by the ICAO in its measurement protocols for aircraft engines. The model is based on the four flight modes of the LTO-cycle. The LTO cycle comprises four stages: taxiing (Idling), starting (Take-off), climbing to 3000 feet (Climb-out) and descending from 3000 feet (Approach). Emissions that occur above 3000 feet (about 1 km) are not included in the emission calculations. Each flight mode corresponds with specific engine settings (power settings) of the aircraft (Idle: 7%, Take-off: 100%, Climb out 85%, Approach 30%). These power settings result in specific fuel consumption per unit of time. For each engine type, the fuel consumption results in a specific emission (emission factor per weight unit of fuel). The equation below shows the calculation of the emission of a specific substance during one year.

$$Emission_y = \sum_{p,m,f} LTO_{p,m} * N_p * FUEL_{m,f} * TIM_{p,f} * EF_{m,f}$$

Where:

- $Emission_y$  = Emission of a specific substance in a specific year (kg/year)
- $LTO_{p,m}$  = Number of Landing and Take-off Cycles per aircraft type (p) with motor type (m) per year; (1/y)
- $N_p$  = Number of engines per aircraft (p);
- $FUEL_{m,f}$  = Fuel consumption of engine (m) in flight mode (f); (kg/s)
- $TIM_{p,f}$  = Duration (abbrev. of Time in Mode) of flight phase (f) for aircraft (p); (s)
- $EF_{m,f}$  = Emission factor of engine (m) per quantity of fuel in flight mode (f); (kg/kg)

The annual number of flight movements per aircraft type serves as the input for the emission calculations. Statistics Netherlands provides annual data for the number of aircraft movements by aircraft type at Dutch airports, distinguishing between domestic and international flights for recent years (CBS, 2021). Furthermore, the StatLine databank of Statistics Netherlands provides figures about the total number of aircraft movements at Dutch airports beginning in 1990 (CBS, 2020a; 2020b). The “Statistical Annual Review” of Schiphol Airport is also used for the flight movements at Schiphol Airport in the years before 2005 (Amsterdam Airport Schiphol, several years). The aircraft types were derived from their ICAO-codes and allocated to the appropriate type present in the CLEO model (ICAO, 2020a). When, for a specific airport, no aircraft types were available for a certain year, the fleet composition of the previous year was used combined with the total number of flights as reported by Statistics Netherlands.

Approximately 400 aircraft types are distinguished in the CLEO model. According to the “Statistical Annual Review” of Schiphol Airport, these include the 40 most frequently appearing aircraft types at Schiphol. The allocation of the aircraft engines to the types of aircraft appearing at Schiphol

Airport is based primarily on the aircraft-engine combinations in use by the “Home carriers” at Schiphol such as KLM. For smaller (piston-engine) aircraft, the Dutch aircraft register was used to see which type of engine was most often equipped by a certain aircraft type in the Netherlands (Ministerie van Infrastructuur en Milieu, 2016).

The duration of the flight modes (except the Idle mode) were derived from the US EPA (1985). The average taxi/idle time (Idle) was calculated based on measurements conducted by the airport (Nollet, 1993) and the RLD<sup>2</sup> for taxi times per individual runway combined with the usage percentages per runway. For heavier aircraft (JUMBO class) a separate TIMCODE category (TIM = Time In Mode) was introduced with somewhat longer times for the flight modes Take-off and Climb-out. This information was obtained at that time from the RLD. For the years 2005 – present, airport-specific taxi times were kindly provided by the Eurocontrol Central Office for Delay Analysis (CODA) for the largest Dutch airports, specified by wake turbulence category (Eurocontrol, 2021). *Table 8.10* shows the TIM times and TIM categories adapted for Schiphol Airport. In the CLEO model, the time of the idle mode can be varied for the aircraft falling under TIMCODE categories JUMBO, TF, TP and TPBUS, which is virtually equivalent with the aircraft movements of all commercial air transport.

The fuel consumption per unit of time during the different stages of the LTO cycle, along with the accompanying fuel-related emission factors, are known for virtually all important aircraft-engine combinations. *Table 8.1* shows the fuel consumption figures. The CO<sub>2</sub> emissions during the LTO-cycle are derived from the fuel consumption. Most emission factors used in the CLEO model have been derived from the [ICAO Engine Emissions DataBank](#) v. 28C (ICAO, 2021). The majority of data in this database was measured as part of the certification of aircraft engines with a thrust greater than 30 kN. During this process, a standard measurement protocol is used that is prescribed by the ICAO (several years). The CLEO model also contains a number of emission factors for smaller (piston) engines. The sources for these emission factors are a report by the Swiss Federal Office for Civil Aviation (Rindlisbacher et al., 2007), and the EPA’s AP42 publication (EPA, 1985). Furthermore, emission factors of aircraft with turboprop engines have been added to the CLEO model. These factors were gathered by the Swedish FFA in the so-called Hurdy-Gurdy-database (FFA, 1996). *Table 8.9* provides the resulting emission factors per type of aircraft for the 50 engine type-aircraft type combinations that most frequently visited Schiphol airport in 2020. This table, with an aggregation of the factors for each flight mode, provides an indication of the variations for each aircraft type. For engine-specific data, the ICAO emissions databank ([ICAO Engine Emissions DataBank](#)) can be consulted. The resulting (implied) emission factors for CO, VOC, NO<sub>x</sub>, PM<sub>10</sub> and CH<sub>4</sub> are shown in *Tables 8.2* through *8.6*.

Emissions from helicopters are calculated based on a study (Rindlisbacher, 2015) that provides emission factors specified by flight phase for most commercial helicopters that are in use nowadays.

Per group of regulated aircraft engines the non-volatile EC<sub>2.5</sub> emission factors are derived from the latest ICAO Engine Emissions DataBank when available. The smoke number of engines is used as input, which is the current regulatory measure of aircraft particulate matter emissions. When only a

---

<sup>2</sup> National air transport service.

smoke number is available, EC<sub>2.5</sub> emission factors are calculated from the smoke number using the FOA4 method described in the latest ICAO DOC 9889 (ICAO, 2020b), which is based on the SCOPE11 method described in Speth et al. (2019). Volatile PM emission factors are estimated using the FOA4 method. PM<sub>10</sub> and PM<sub>2.5</sub> emission factors are represented by the sum of the volatile and non-volatile (EC<sub>2.5</sub>) emission factors. For most piston and turboshaft engines, EC<sub>2.5</sub> emission factors are reported by Rindlisbacher et al., (2007; 2015). For other non-regulated engines, PM<sub>2.5</sub> and EC<sub>2.5</sub> emissions are calculated from PM<sub>10</sub> by using an emission profile (Table 8.11).

The calculation of the combustion emissions of VOC and PAH components, including methane, takes place using VOC and PAH species profiles, as shown in Tables 8.8A and 8.8B. First, as described above, the combustion emissions of VOC are calculated. The profiles indicate the fractions of the various VOC and PAH components in total VOC. By multiplying total VOC emissions with the fractions from these profiles, the emissions of individual VOC and PAH components are estimated.

Emissions of lead and SO<sub>2</sub> are directly related to the characteristics of the fuel type used. For jet fuel, emission factors of SO<sub>2</sub> are based on the EMEP/EEA guidebook (EMEP/EEA, 2016). For AvGas, the SO<sub>2</sub> emission factors are based on the Dutch SO<sub>2</sub> emission factors for petrol (see Table 3.7). There are no lead emissions for jet fuel. The emission factor for lead in AvGas is estimated based on the lead content of AvGas 100LL, which is the most commonly used fuel type for piston engines. Note that in recent years unleaded types of AvGas have been introduced which reduce the lead emissions of AvGas fuelled aircraft. For years 2015-2019, TOTAL provided the share of unleaded AvGas (UL91) sold on Lelystad airport, the only airport in the Netherlands known to sell UL91 (Helsen, 2020). For these years, the lead emissions for this airport have been reduced with the share of unleaded AvGas sold. The SO<sub>2</sub> and lead emission factors are shown in Table 8.14. Other metal emissions are assumed to be negligible.

### 8.2.2 Emissions from tyre and brake wear

The PM emissions from tyre and brake wear are calculated for Schiphol and the regional airports. The calculation is based on the number of take-offs and average emission factors based on the Maximum permissible Take-off Weight (MTOW). This methodology is described by British Airways (Morris, 2007). The emission factors can be found in Table 8.13. The speciation profiles for heavy metals can be found in table 8.8C and are applied as a fraction of total PM<sub>10</sub> or PM coarse emissions.

$$Emissions_y = MTOW_y * EF_{tyre}$$

$$Emissions_y = MTOW_y * EF_{brake}$$

Where:

Emission <sub>y</sub>	= Emission of a specific substance in a specific year; (kg/year)
MTOW <sub>y</sub>	= Total summed MTOW of aircraft LTO's; (tonne/y)
EF <sub>tyre</sub>	= PM emission factor for tyre wear; (g/t MTOW)
EF <sub>brake</sub>	= PM emission factor for brake wear; (g/t MTOW)

### 8.2.3 Emissions from auxiliary power units

The emissions of Auxiliary Power Units (APU) in aircraft are calculated based on the estimated quantity of fuel that is consumed during power generation. Information on the type of APU that is installed in specific aircraft types is taken from a report for the Global Atmosphere Division of DEFRA (Netcen, 2004), while emission factors and fuel use for these APU types are also based on Netcen (2004) and on data from KLM (KLM, 2016).

The typical APU running time between landing and take-off may differ per aircraft type and airport. To limit APU emissions, several airports limit the allowed running time of APU's and require aircraft to use fixed electricity connections and preconditioned air instead. Especially Schiphol airport has introduced stricter rules concerning APU use. Since this is also the largest airport, the model includes year dependent APU running times for Schiphol Airport, while for the other airports a default running time of 45 minutes per LTO cycle is assumed based on the value for short-haul aircraft operation in the ICAO airport air quality manual (ICAO, 2011). APU emissions for the applicable aircraft types are calculated using the following equation:

$$Emission_y = \sum_{apu} LTO_{apu} * FUEL_{apu} * TIME_{airport} * EF_{apu}$$

Where:

$Emission_y$	= Emission of a specific substance in a specific year; (kg/year)
$LTO_{apu}$	= Number of LTO cycles per APU type per year; (1/y)
$FUEL_{apu}$	= Fuel consumption of APU; (kg/s)
$TIME_{airport}$	= Duration of APU use per LTO at airport; (s)
$EF_{apu}$	= Emission factor of APU per quantity of fuel; (kg/kg)

### 8.2.4 Emissions from ground support equipment

Emissions of ground support equipment (GSE) at Schiphol Airport are estimated by KLM Equipment Services (KES). KES is responsible for maintenance and refuelling of 95% all GSE at Schiphol Airport. Fuel consumption of all individual equipment (more than 1800 units) is monitored annually. For each unit the emission-category (33 categories) is determined. The equipment engine emission factors are set equal to the EU-emission limit values. A greater part of KLM ground power units have engines that are cleaner than legal emission limit values. Data of the producers measurement reports are applied instead of EU-emission limit values for those GPU's for which emission measurement data from producers are available.

The general formula that is applied by KES in the emission calculation at Schiphol Airport is:

$$Emission (g) = FC (L) * \rho (g/L) / engine-efficiency (g/kWh) * EF (g/kWh)$$

Total annual emissions of GSE at Schiphol Airport were divided by total MTOW of all LTO-cycles in order to determine implied emission factors of GSE:

$$EF_{implied,schiphol} = \Sigma Emission / \Sigma(LTO_{ac} * MTOW_{ac}) \text{ (data from Schiphol Airport)}$$

The implied emission factors can be found in *Table 8.12*. Data for the range of years between 1996 onwards as determined by the methodology described above was delivered by KES (Feldbrugge,

2021). For earlier years, the 1996 emission factors are used.

For the regional airports (Eindhoven, Rotterdam, Lelystad, Groningen and Maastricht), the GSE fuel use is estimated based on the total MTOW. Since GSE is mostly needed for larger aircraft, only aircraft with an MTOW larger than or equal to 6 tonnes are counted towards the total MTOW. A year dependent and declining factor between 0.44 (1990) and 0.38 (2019) litre diesel per tonne MTOW is assumed, which is based on the GSE at Schiphol airport. The formula applied to calculate emissions of other airports is:

$$\text{Emission (g)} = \text{EF}_{\text{implied, schiphol}} * \sum (\text{LTOac} * \text{MTOWac})$$

## 8.2.5 Emissions from storage and transfer of jet fuel

Due to expulsion of jet fuel vapour when loading fuel, some jet fuel vapour is released during refuelling. It is assumed that the volume of air that is driven out while tanking is saturated with jet fuel vapour. The emissions are only calculated for Schiphol and the regional airports as the emissions on the other airports are expected to be negligible. The emission factor is based on an environmental report by Aircraft Fuel Supply (AFS), the company which handles all aircraft fuelling and fuel handling at Schiphol airport. A Kerosene Vapour Processing System (KVPS) was installed in 2012, which led to a reduction in the emission factor (AFS, 2013). For the regional airports, the Schiphol emission factor without KVPS was assumed for all years.

Expressed as a formula, the calculation appears as follows:

$$\text{EMISSION}_y = \text{VOLUME}_y * \text{EMISSION FACTOR}$$

Where:

$\text{EMISSION}_y$  = Emissions (of volatile organic substances) in one year (kg/y)

$\text{VOLUME}_y$  = Total quantity of jet fuel tanked in one year (kt/y)

$\text{EMISSION FACTOR}$  = The quantity of hydrocarbon emissions per quantity of fuel tanked (kg/kt)

## 8.3 Uncertainties

In 2016, an expert workshop was organized with the members of the Task Force Transportation in the Dutch PRTR to discuss and estimate the uncertainties in the activity data and emission factors used for the emission calculations for the transport sector. Uncertainties were estimated at the level of the NFR source categories. The setup and outcomes of the workshop are described in Dellaert & Dröge (2017). The report also compares the estimates resulting from the workshop to estimates reported by other countries and default estimates from the Emission inventory guidebook. The resulting uncertainty estimates for civil aviation are provided in table 8B. These uncertainty estimates are reassessed annually or when changes to the methodology have been implemented.

The uncertainty in activity is deemed rather small for LTO use of jet kerosene, use of diesel for ground service equipment, fuelling and fuel handling and for MTOW (which is used to estimate wear emissions). Uncertainty in LTO use of avgas is estimated at 20%, whereas uncertainty in APU use of jet kerosene is rather large. Uncertainty in emission factors is higher due to a lack of

measurements and the typically substantial bandwidth in reported emission measurement values. This holds specifically for PM, EC and NMVOC.

**Table 8B**  
Uncertainty estimates for civil aviation (Dellaert & Dröge 2017)

Type	Fuel type	Uncertainty activity data	Uncertainty implied emission factors					
			NO <sub>x</sub>	SO <sub>x</sub>	NH <sub>3</sub>	PM <sub>10</sub>	PM <sub>2.5</sub>	NMVOC
LTO	Jet Kerosene	10%	35%	50%		200%	200%	200%
LTO	Aviation gasoline	35%	100%	50%		100%	100%	500%
APU	Jet Kerosene	50%	50%	50%		100%	100%	200%
<b>Fuelling and fuel handling</b>		20%						100%
GSE	Diesel	10%	50%	20%	200%	100%	100%	
<b>Tyre &amp; brake wear</b>		10%					100%	

## 8.4 Points for improvement

### Exhaust emissions

- The values of time-in-modes for various aircraft types may have changed in years due to other configurations of the airport(s) or changed flight procedures (for instance Continuous Descent Approach (CDA) that have been introduced gradually and cause fewer emissions during Approach). Current time-in-mode values should be re-evaluated.
- APU running time for all years and all airports has been estimated based on a few literature values. Year and airport specific data on APU running time could be used to improve the APU emissions calculation.
- Cruise emissions are currently not estimated.

## 9 Non-Road Mobile Machinery

### 9.1 Source category description

Non-Road Mobile Machinery (NRMM) covers a variety of equipment that is used in different economic sectors and by households in the Netherlands. NRMM is defined as all machinery (traditionally) equipped with a combustion engine which is not primarily intended for transport on

public roads and which is not attached to a stationary unit. The most important deployment of NRMM in the Netherlands is the use in agriculture and construction, but NRMM is also used in industrial and commercial sectors and in residential settings. The largest volumes of fuel are used in tillage, harvesting and earthmoving. Furthermore, NRMM is used for nature and green maintenance, such as in lawn mowers, aerator machines, forest mowers and leaf blowers. Emissions from NRMM result from the combustion of fossil fuels and biofuels in the engines of the machinery. NRMM mostly uses diesel fuel, but gasoline and LPG are also used, as well as a gradual introduction of battery- or cable-electric machinery as an alternative to machines with combustion engines.

The emissions of air pollutants from NRMM are reported under different source categories in the NFR, as is shown in Table 9A.

**Table 9A**  
Emission reporting for non-road mobile machinery in the NFR

<b>NFR code</b>	<b>Source category description</b>	<b>Economic sectors</b>
<b>1A2gvii</b>	Mobile combustion in manufacturing industries and construction	Industry, construction
<b>1A4aii</b>	Commercial/Institutional: Mobile	Commercial
<b>1A4bii</b>	Residential: Household and gardening (mobile)	Residential
<b>1A4cii</b>	Agriculture/Forestry/Fishing: Off-road vehicles and other machinery	Agriculture

## 9.2 Activity data and (implied) emission factors

The emissions of air pollutants from NRMM are calculated using a Tier-3 methodology. As several model updates introduced in 2021 led to a significant increase in modelled NRMM fuel use and emissions, which could not be properly validated in time, the Task Force Transportation had chosen to scale the fuel use to the level of the previous time series and apply the same scaling factor to the emissions. In 2022, additional validation steps and further model improvements were implemented, leading to a more reliable result, which allowed to abandon the scaling of fuel use and emissions. The new time series for 1990 – 2021 thus includes substantial changes that follow from a large number of model updates and improved data sources.

### 9.2.1 Activity data

Fuel consumption by mobile machinery in the different economic sectors is not reported separately in the Energy Balance. Therefore, fuel consumption and resulting emissions from NRMM are calculated using a modelling approach, developed by TNO (Hulskotte & Verbeek, 2009). The so-called EMMA model uses sales data and survival rates for different types of machinery to estimate the composition of the active NRMM fleet. Assumptions on the average use (annual operating hours) and the engine load profile are combined with the rated power output (in kW) and load dependent fuel and emission factors to estimate total fuel consumption and emissions of NRMM, including from machine idling. The methodology used in the EMMA model is similar to the methodology used in the EPA NON-ROAD USA model by the US Environmental Protection Agency (EPA), as described in Harvey et al. (2003). Emission factors were originally taken from a similar

model TREMOD-MM (Lambrecht et al., 2004) and partially updated with data taken from Helms et al. (2010).

Annual sales data for different types of NRMM are derived from different trade organizations such as BMWT and Federatie Agrotechniek, supplemented with sales statistics derived from Off-highway Research, a commercial party. Most sales data are only available back to the year 2000 or 2002, therefore making it necessary to extrapolate sales data back to earlier years, causing significant uncertainty on the size and composition of the machine fleet in the beginning of the time series.

In 2021 and 2022, two additional sources of data on the Dutch machine fleet became available that allowed for an improvement of the model representation:

- In the beginning of 2021, a survey was held among companies/contractors that use mobile machinery such as cranes, tractors, generator sets, vibrating plates etc. The survey was distributed through several branch organizations in the Netherlands and was completed by almost 100 respondents. The survey asked for detailed information on the fleet at the level of individual machines, such as age, engine type, rated power, annual working hours and emission class. The study results are described (in Dutch) in Dellaert et al. (2021). Based on the findings of the survey study, several machinery types were added to the EMMA model (e.g. pile drivers, mobile drilling rigs, light towers, several types of cranes, and additional types of mobile pumps and generator sets), and many parameters such as the annual working hours and median lifetime of individual machine types have been updated.
- As of January 1<sup>st</sup> 2022, all vehicles, including mobile machinery, that access the public road with a speed above 6 km/h must be registered in a national database and obtain a licence plate, similar to the existing registration of passenger cars and other road transport vehicles. This public database, maintained by the RDW (Dienst Wegverkeer, an administrative body of the Dutch government) can be queried and for the first time makes available a relatively complete overview of the Dutch NRMM fleet, which was notably lacking before. While this registration applies to the current machine fleet, and excludes some machinery types that do not typically use public roads (e.g. crawler excavators), it includes information such as the brand and model of the machine, the fuel type, and the date of first registration of the machine, which is typically close to the construction year of the specific machine. This information gives substantially more insight in the Dutch machine fleet, even related to historic years. For several machine types, the data in this data has been processed and included in the current model, for example the inclusion of a completely new machine category; the yard- or terminal tractors. For other machine types, additional data processing and analysis is needed to include new insights into the model.

In addition to new data sources on the machine fleet, several important changes to the modelling were introduced:

- Dynamic annual working hours that decline as the machines are older;
- An updated machine scrappage function, based on the scrappage rates of medium-heavy trucks in the Netherlands;
- Further extended the extrapolation of machine sales data back to 1970, where it was only extrapolated to 1986 before. This leads to a more realistic composition of the machine fleet at the beginning of the time series, which matches better the available data on the construction year build-up of the current machine fleet. However, it also leads to a substantial increase in emissions and fuel use at the beginning of the time series. While



there is much uncertainty on the actual fleet size and activity in this time period, the new higher fuel consumption estimates are much closer to independent data on diesel fuel sales to mobile machinery in the period 1990 – 2012, when there was still a special reduced tax tariff for diesel sales to NRMM.

- Introduction of electric machinery replacing some of the sales of traditional machinery in recent years. This has been briefly documented in Dellaert (2022);
- The implementation of the previously separate emission calculation for container handling machinery into the EMMA model to improve consistency;
- Updated calculation of CO<sub>2</sub> emissions and fuel consumption, leading to significant changes in the emission intensity (gram pollutant / gram of fuel) in some cases.

Fuel consumption and CO<sub>2</sub> emissions are calculated using a Willans line approach with the following formula:

$$\text{CO}_2 \text{ emission} = \text{Number of machines} \times \text{active time} \times 0.5 \times (1 + F[\text{year}]) \times (0.4 + 0.0025 \times \text{Prated}) + 0.20 \times F[\text{year}] \times (1 + \exp(-\text{Prated}/5)) \times (\text{Prated} \times \text{average engine load}) \times \text{correction factor}[\text{fuel}] \quad (9.1)$$

$$\text{Fuel consumption} = \text{CO}_2 \text{ emission} / \text{CO}_2 \text{ intensity}[\text{fuel}] \quad (9.2)$$

In which:

- CO<sub>2</sub> emission = Emission (grams);
- Fuel consumption = consumption of fuel (grams);
- Number of machines = the number of machines of a certain year of construction with emission factors applicable to the machine's year of construction (.);
- Active time = the average annual running time for this type of machinery (s);
- F[year] = engine efficiency factor relative to machine construction year 2010 (.);
- Prated = rated engine power (kW);
- Average engine load = average load of the engine (%);
- Correction factor[fuel] = correction factor to translate from average fuel economy of diesel engines to petrol or LPG engines. Value is 1.17 for petrol, and 1.07 for LPG (.);
- CO<sub>2</sub> intensity[fuel] = the CO<sub>2</sub> intensity for the specific fuel used (3.1 for diesel and petrol, 2.8 for LPG) (g/g).

The engine efficiency is assumed to improve with 1% each (machine construction) year, yielding a F[year] value of 1.4889 in 1970, 1 in 2010, and 0.9044 in 2020.

The associated emissions of CO, NO<sub>x</sub>, PM, NH<sub>3</sub> and VOC are calculated using the following formula:

$$\text{Emission} = \text{Number of machines} \times \text{active time} \times \text{Share of time in load range} \times \text{Rated power} \times \text{Load and power dependent emission factor} \quad (9.3)$$

In which:

- Emission = Emission or fuel consumption (grams);
- Number of machines = the number of machines of a certain year of construction with emission factors applicable to the machine's year of construction;
- Active time = the average annual running time for this type of machinery in seconds;
- Share of time in load range = the average fraction of time that the machine engine is in a specific load range;
- Rated power = the average full power for this type of machinery (kW);

- *Load and power dependent* emission factor = Specific load dependent emission and fuel consumption factors, per kW of rated power for different technology levels related to the year of construction and the emission standards, in grams/second\*kW (rated).

The distribution of total fuel consumption to different economic sectors is estimated using different data sources. In order to estimate the energy use for each of the five sectors as reported in Table 9A, the different types of machinery in EMMA are distributed over these five sectors, with some machine type (e.g. tractors) distributed over multiple sectors.

Total fuel consumption by NRMM in the commercial and industrial sector and by households is derived directly from EMMA. Fuel consumption in agriculture, construction and container handling, as initially calculated by the model, are adjusted.

Fuel consumption by NRMM in the agricultural sector (excluding agricultural contractors) is derived from the LEI research institute of Wageningen University and Research Centre. Fuel consumption by agricultural contractors has been estimated and provided by the trade organization for agricultural contractors in the Netherlands (CUMELA). Both data sources are combined to estimate total fuel consumption by mobile machinery in the agricultural sector and scale the model results.

The fuel consumption by NRMM in the construction sector is adjusted to take into account the impact of economic fluctuations. Because EMMA is based on sales data and assumptions on the average annual use of the machinery, it is not able to properly take into account quick-acting effects due to changes in the economic situation on activities in the construction sector (e.g. an economic recession) which may lead to variations in the usage rates of the present machinery stock (i.e. the annual operational hours), while the effect on the total size of the machine stock will only clearly materialize after a time delay of several years. The EMMA results for the construction sector are therefore adjusted based on economic indicators from Statistics Netherlands for the specific sectors where the machinery is used.

Mobile machinery used at container terminals was previously modelled separately from the other machinery using the methodology described in Dellaert (2016). While the calculation has remained very similar to the one described, the calculations have now been incorporated into the EMMA model to improve consistency. Mobile machinery typically found at container terminals are reach stackers, empty handlers, straddle carriers, tug masters, forklifts and automated guided vehicles. The EMMA model generates an average fleet composition (engine size, production year) for the Netherlands for the entire time span starting in 1990. The fleet composition is then combined with data on the total number of container handlings in the Netherlands, and the average (effective) energy needed to handle one TEU (Twenty feet Equivalent Unit) container to calculate annual emissions that are thus adjusted to correspond to the annual total number of containers handled in the Netherlands. The total number of container handlings is derived from a complete time series for container handlings in the port of Rotterdam in combination with data from the Dutch Statistical Agency.

The adjusted EMMA results are used to calculate emissions from NRMM. The resulting fuel consumption (energy use) is also reported by Statistics Netherlands in the Energy Balance, and is included in Table 9.1. The annual correction factors used to adjust the energy use as reported by EMMA are shown in Table 9.9. Table 9.10 shows the resulting energy use before and after the adjustment.

## 9.2.2 Emission factors

The emissions of NO<sub>x</sub>, PM<sub>10</sub>, CO, NH<sub>3</sub> and VOC are calculated using detailed emission factors per engine type, fuel type and emission legislation class. The TNO report on the EMMA model (Hulskotte and Verbeek, 2009) provides the base emission factors for the various technologies and the different stages in the European emission legislation for NRMM. The emission factors are linked to the different machine types per sales year. Base emission factors were derived from different (literature) sources. In 2017 and 2022, emission measurements were performed by TNO on several types of NRMM to assess the load profile and actual NO<sub>x</sub> and CO<sub>2</sub> emissions during use and idling (Ligterink et al., 2018; van Kempen et al., 2022). Based on these measurements, the NO<sub>x</sub> emission factors for several diesel engine categories have been improved in the model to better match the emissions under practical-use conditions.

In 2020, new measurements allowed to generate 7 representative engine load profiles, existing of percentages of time spent in a specific engine load range (e.g. 10% of time in 20%-30% engine load). Next, the base emission factors for NO<sub>x</sub>, PM<sub>10</sub>, CO, NH<sub>3</sub> and VOC (in g/kWh) were converted to load specific emission factors (in g/s \* kW) assuming a typical response curve of emission/load that is observed for CO<sub>2</sub> emissions. This CO<sub>2</sub> response curve is relatively linear. For modern engines, the NO<sub>x</sub> response curve is known to deviate significantly, showing an almost flat response of NO<sub>x</sub> emissions at different levels of engine load. For this reason, the load specific emission factors for NO<sub>x</sub> from STAGE IV and V engines has been derived using this more flat response curve. Each machine type was then assigned one of the engine load profiles, based on the typical use and machine components (e.g. hydraulics). This new calculation setup removes the need for a separate calculation of emissions from idling and allows a more direct use of measured emission rates and engine load profiles in the EMMA model.

Based on findings on tampering incidence in trucks (motivated by reduced maintenance and repair costs), incidence in tampering with SCR catalysts and particulate filters was estimated also for NRMM. For NO<sub>x</sub>, tampering of SCR catalysts is assumed to happen in 10% of STAGE IV and V machines. For PM, tampering with particulate filters is assumed to happen in 5% of STAGE V machines.

For methane (CH<sub>4</sub>) emissions, the same emission profile for VOC-components are used as in road traffic, which can be found in Table 3.10.

Resulting (implied) emission factors for NO<sub>x</sub>, PM<sub>10</sub>, CO, VOC, CH<sub>4</sub> and NH<sub>3</sub> for the entire time series are shown in Tables 9.2 – 9.7. PM<sub>2.5</sub> emissions are derived as a fraction of PM<sub>10</sub> emissions, using the fractions shown in Table 9.8. Emissions from different VOC and PAH components are derived from total VOC emissions, as calculated using formula 8.1, using specific VOC and PAH profiles, which are shown in Table 9.11A and 9.11B. By multiplying total VOC emissions with the fractions from these profiles, the emissions of individual VOC and PAH components are estimated. The emission factors for heavy metals are shown in Table 9.11C (Pulles et al., 2012).

## 9.3 Uncertainties

In 2016, an expert workshop was organized with the members of the Task Force Transportation in the Dutch PRTR to discuss and estimate the uncertainties in the activity data and emission factors used for the emission calculations for the transport sector. Uncertainties were estimated at the

level of the NFR source categories. The setup and outcomes of the workshop are described in Dellaert & Dröge (2017). The report also compares the estimates resulting from the workshop to estimates reported by other countries and default estimates from the Emission inventory guidebook. The resulting uncertainty estimates for non-road mobile machinery are provided in table 9B. These uncertainty estimates are reassessed annually or when changes to the method have been implemented.

Uncertainty in activity data is deemed highest for use of petrol due to a lack of data on specific fuel consumption. Uncertainty in emission factors is smallest for NO<sub>x</sub> and SO<sub>2</sub> and large for PM, EC, NH<sub>3</sub> and NMVOC due to a lack of emission measurements for most types of equipment. Uncertainty estimates for activity data of construction and industry were adjusted upwards as sales data for 2015-2020 are less detailed than were available in previous years.

**Table 9B**  
Uncertainty estimates for NRMM (Dellaert & Dröge 2017)

NFR category	Sector	Fuel type	Uncertainty activity data	Uncertainty implied emission factors					
				NO <sub>x</sub>	SO <sub>x</sub>	NH <sub>3</sub>	PM <sub>10</sub> /P M <sub>2.5</sub>	EC	NMVOC
1A2gvii	Construction	Petrol	100%	50%	20%	200%	100%	100%	100%
1A2gvii	Construction	Diesel	50%	50%	20%	200%	100%	100%	100%
1A2gvii	Industry	Diesel	50%	50%	20%	200%	100%	100%	100%
1A2gvii	Industry	LPG	50%	50%	20%	200%	100%	100%	100%
1A4aai	Public services	Petrol	100%	50%	20%	200%	100%	100%	100%
1A4aai	Public services	Diesel	50%	50%	20%	200%	100%	100%	100%
1A4aai	Container handling	Diesel	50%	50%	20%	200%	100%	100%	100%
1A4bii	Consumers	Petrol	100%	100%	20%	200%	200%	200%	200%
1A4cii	Agriculture	Petrol	200%	100%	20%	200%	200%	200%	200%
1A4cii	Agriculture	Diesel	35%	50%	20%	200%	100%	100%	100%

## 9.4 Points for improvement

The current methodology to estimate emissions from NRMM could be improved regarding:

- With the new registration of NRMM, a lot of data on the current machine fleet has become available. Some of the data has been processed and implemented already, but further analysis will likely allow for more improvements to the model and the input data.
- Although the model updates improve the correspondence between the calculated diesel consumption for all NRMM-sectors, and the available diesel sales statistics, especially in the beginning of the time series there are still some differences (up to 10-15%). The comparison with historical diesel sales also indicated that the model may underestimate the effect of the economic crisis. Further model improvements may be needed, resulting from additional analyses of the new RDW registry.
- The diesel used in the construction sector is liable to relatively strong economic fluctuations. At present the correction for this phenomenon takes place using economic

indicators derived from Statistics Netherlands instead of physical indicators. It should be investigated if there are enterprises or institutions that have figures of diesel consumption at their disposal.

- There is a lack of input data for several types of machinery and sectors. In the garden sector and private households weakly founded or extrapolated figures have been used to estimate the size of the fleet. With targeted research into these data, relatively high figures for the VOC emissions could be replaced by improved figures.
- The effect of varying engine loads on emissions has been examined and implemented. It is of great importance that engine load profiles and related emission factors are investigated and improved further. Specific measurement programmes for investigating the effect of transient engine loads in the machine's daily practice are needed for a better foundation of the emission data.
- Via a specific measurement scheme, the effect of longer or shorter postponed maintenance on the emissions of building machinery due to highly varying hire and lease practices, as they occur in the market, could be further investigated.

# References

## Chapter 1

- IPCC (2006), 2006 IPCC Guidelines for National Greenhouse Gas Inventories, Prepared by the National Greenhouse Gas Inventories Programme, Eggleston, H.S., Buendia, L., Miwa, K., Ngara, T. and Tanabe, K. (eds). Published: IGES, Japan.
- RIVM (2023a), Greenhouse gas emissions in the Netherlands 1990-2021. National Inventory Report 2023, National Institute for Public Health and the Environment, Bilthoven.
- RIVM (2023b), Emissions of transboundary air pollutants from the Netherlands 1990-2021. Informative Inventory Report 2023, National Institute for Public Health and the Environment, Bilthoven.
- UNECE (2015), Guidelines for reporting emissions and projections data under the convention on long-range transboundary air pollution. ECE/EB.AIR/128, United Nations Economic Commission for Europe, United Nations, New York and Geneva.

## Chapter 2

- EEA (2013) EMEP/EEA Emission Inventory Guidebook 2013, European Environmental Agency, Copenhagen.
- Gense, N.J. & Vermeulen, R.J. (2002), N<sub>2</sub>O-emissions from passenger cars, TNO report 02.OR.VM.016.1/NG, TNO Automotive, Delft,
- Harvey, C., Carey, P. & Warila, J. (2003) EPA's newest draft nonroad emission inventory model, 12th International Emission Inventory Conference, San Diego, California.
- Hulskotte, J.H.J. (2004), Protocol voor de jaarlijkse bepaling van de emissies van specifieke defensie-activiteiten conform de IPCC-richtlijnen, TNO-rapport R2004/405 (in Dutch).
- Hulskotte J.H.J. & Verbeek R. (2009), Emissiemodel Mobiele Machines gebaseerd op machineverkoop in combinatie met brandstofafzet (EMMA), TNO-034-UT-2009-01782\_RPT-ML.
- IPCC (2006), 2006 IPCC Guidelines for National Greenhouse Gas Inventories, Prepared by the National Greenhouse Gas Inventories Programme, Eggleston, H.S., Buendia, L., Miwa, K., Ngara, T. and Tanabe, K. (eds). Published: IGES, Japan.
- Kuiper, E. & Hensema, A. (2012), N<sub>2</sub>O emissies van wegverkeer, TNO-060-DTM-2012-02977, TNO, Delft.
- Ligterink, N.E. (2016), Dutch market fuel composition for GHG emissions, TNO report 2016 R10700, TNO, Utrecht.
- Ligterink, N.E. (2020), Petrol fuel and blending ethanol analyses, TNO report R10138.
- Ligterink, N.E., Verbeek, R.P. and Cuelenaere, R.F.A. (2020) Petrol fuel quality and its effect on the vehicle technology and the environment, TNO 2020 R11950, TNO, Den Haag.
- NEa (2019) Rapportage Energie voor Vervoer in Nederland 2018, Den Haag: Nederlandse Emissieautoriteit.
- NNWB (2008), Exhaust from recreational boats, Netherlands National Water Board in cooperation with Deltares and TNO.

- Olivier, J.G.J. (2004), Note on Netherlands' CO<sub>2</sub> emission factors for petrol, diesel and LPG. Version 2, December 2004. MNP document No. M/773201/01/NI, Bilthoven.
- Riemersma, I., Jordaan, K. & Oonk, H. (2003), N<sub>2</sub>O emissions of HD vehicles, TNO report 03.OR.VM.006/IJR, TNO Automotive, Delft.
- Ruiter, J.M. de & Van Mensch (2022), Analysis of the emission performance of the vehicles tested for the Green Vehicle Index (GVI) project, TNO report R10798.
- Sempos, I. (2018), Note on fossil carbon content in biofuels
- Spreen, J.S., G. Kadijk, R.J. Vermeulen, V.A.M. Heijne, N.E. Ligterink, U. Stelwagen, R.T.M. Smokers, P.J. van der Mark & G. Geilenkirchen (2016), Assessment of road vehicle emissions: methodology of the Dutch in-service testing programmes, TNO 2016 R11178, TNO, Delft.
- Stelwagen, U. & Ligterink, N.E. (2014), CO<sub>2</sub> emission from urea consumption in SCR after-treatment systems in heavy-duty vehicles, TNO 2014 R11513, Utrecht: TNO.
- Swertz, O., S. Brummelkamp, J. Klein & N. Ligterink, 2017: Adjustment of heating values and CO<sub>2</sub> emission factors of petrol and diesel, Statistics Netherlands, The Hague.
- Zijlema, P.J. (2023), The Netherlands: list of fuels and standard CO<sub>2</sub> emission factors, version 2023.

## Chapter 3

- Asch, R. van, Verbeek, R.P., Ligterink, N.E., Kadijk, G. (2009), Real world efficiency of retrofit partial-flow diesel particulate filters for trucks, TNO report.
- Asch, R. van & R. Verbeek (2009), Evaluation of particulate filtration efficiency of retrofit particulate filters for light duty vehicles, MON-RPT-033-DTS-2009-03304.
- Barlow, T.J. et al. (2007), Non-exhaust particulate matter emissions from road traffic: Summary Report, TRL report PPR231.
- Boer, L.C. den, M.J.J. 't Hoen & M.B.J. Otten (2015), Update rekenmodule emissies autobussen. Ten behoeve van de emissieregistratie, Delft: CE Delft.
- Boulter, P.G., Thorpe, A.J., Harrison, R.M., Allen, A.G. (2006), Road vehicle non-exhaust particulate matter: final report on emission modelling, TRL report PPR110.
- Carlsaw, D. Farren, N., Borken-Kleefeld, J. Sjodin, A. (2019), IVL report C387.
- CBSa (several volumes), Het bezit en gebruik van bedrijfsvoertuigen (ownership and use of commercial vehicles), CBS, Voorburg/Heerlen. Discontinued.
- CBSb (several volumes), Inkomend toerisme: toeringspassagiers in Nederland (coach passengers in The Netherlands). A.Maas, W.E. Bernelot Moens. Sociaal-culturele berichten 1988-3.
- CBS (1996), Mobiliteit in Nederland; Resultaten onderzoek verplaatsingsgedrag 1995, CBS, Den Haag.
- Dellaert, S.N.C. & R. Dröge (2017), Uncertainty of the NO<sub>x</sub>, SO<sub>x</sub>, NH<sub>3</sub>, PM<sub>10</sub>, PM<sub>2.5</sub>, EC<sub>2.5</sub> and NMVOC emissions from transport, TNO 2017 R10854, TNO, Utrecht.
- Denier van der Gon, H., Ten Broeke, H. & Hulskotte, J. (2008), Emissies door wegdeklijtage ten gevolge van het wegverkeer, Rijkswaterstaat Waterdienst.
- Dröge, R., Hensema, A., ten Broeke, H., Hulskotte, J. (2011) Emissions of two-wheeled vehicles. TNO-report TNO-060-UT-2011-01556, Utrecht.
- Duijnhoven, N. van & Van der Gon, H.G. (2016), Factsheet Emissieschattingen Diffuse bronnen, Bandenslijtage wegverkeer, Deltares & TNO.
- Duijnhoven, N. van (2021), Memo Nieuwe emissiefactoren bandenslijtage, Deltares.

- EEA (2007), EMEP/CORINAIR Emission Inventory Guidebook 2007. European Environment Agency, Copenhagen, Denmark.
- Eijk, A.R.A., P. van Mensch, & M. Elstgeest (2017), Tailpipe emissions of mopeds in the Dutch fleet, TNO 2017 R11495, Den Haag: TNO.
- EU (2002), EU Publication sheet, C 145 E/71, 2002-6-18.
- FAPETRO (1999), Verslag van de activiteiten van het fonds voor de analyse van petroleumproducten.
- FAPETRO (2000), Verslag van de activiteiten van het fonds voor de analyse van petroleumproducten.
- Feenstra, J.F. & P.J.F. van der Most (1985), Diffuse bronnen van waterverontreiniging, IVM-rapport E85/15, Instituut voor Milieuvraagstukken (IVM), Amsterdam.
- Gijlswijk, R.N. van, J.M. de Ruiter, A.P. Indrajana, U. Stelwagen and N.E. Ligterink (2021), Model M2: refinement of the real-world CO<sub>2</sub> emission estimation of passenger cars based on vehicle use. Deliverable D C3.2, Delft: TNO.
- Gijlswijk, R. N. van, M. Paalvast, N. E. Ligterink, and R. T. M. Smokers (2020), Real-World Fuel Consumption of Passenger Cars and Light Commercial Vehicles : TNO, 2020. — TNO 2020 R11664
- Gijlswijk, R.N. van, Ligterink, N.E., Bhoraskar, A., Smokers, R.T.M. (2022), Real-world fuel consumption and electricity consumption of passenger cars and light commercial vehicles – 2021, TNO report R10409.
- Goudappel Coffeng (2010), Onderzoek naar de wegtypeverdeling en samenstelling van het wegverkeer. Eindrapport, Goudappel Coffeng, Deventer.
- Heeb, N.V., A.-M. Forss & M. Weilenman (2002), Pre- and post-catalyst-, fuel-, velocity- and acceleration- dependent benzene emission data of gasoline-driven Euro-2 passenger cars and light-duty vehicles, Atmospheric Environment, Vol. 26, pp. 4745-4756.
- Hooftman, N, Ligterink, N.E., Bhoraskar, A, (2020), Analysis of the 2019 Flemish remote sensing campaign, [Vlaams Planbureau voor Omgeving](#), Brussel.
- Kadijk, G., M. Elstgeest, N.E. Ligterink & P.J. van der Mark (2018), Emissions of twelve petrol vehicles with high mileages, TNO 2018 R11114, Den Haag: TNO.
- Kadijk, G., Ligterink, N.E. & Spreen, J.S. (2015), On-road NO<sub>x</sub> and CO<sub>2</sub> investigations of Euro 5 Light commercial vehicle, TNO report.
- Kadijk, G., Elstgeest, M. Ligterink, N.E., Van Der Mark, P.J. (2018), Emissions of twelve petrol vehicles with high mileages, TNO report R11114.
- Kadijk, G., et al. (2020), On road emissions of 38 petrol vehicles with high mileages, TNO report R11883.
- Kampert A., Van Melis, J., Molnár-in 't Veld, H., Sijstermans, M. & Willems, R. (2014), Methodierapport verkeersprestaties speciale voertuigen, Statistics Netherlands, Den Haag/Heerlen.
- Klein et al. (2019) Methods for calculating the emissions of transport in the Netherlands
- Kraan, T.C., Ligterink, N.E. & Hensema, A. (2014), Uncertainties in emissions of road traffic: Euro-4 diesel NO<sub>x</sub> emissions as case study, TNO 2012 R11316, Delft: TNO.
- Kruiskamp, P., Molnár-in 't Veld, H., Ligterink, N. (2015), Bottom-up berekening CO<sub>2</sub> van bestelauto's (in Dutch). Statistics Netherlands (CBS), Den Haag/Heerlen.
- LeFranc, F. (1999), Update VERSIT light-duty vehicles, TNO Automotive, Delft.



- Ligterink, N.E. & Lange, R. de (2009), Refined vehicle and driving behaviour dependencies in the VERSIT+ emission model, ETAPP symposium.
- Ligterink, N.E., Lange, R. de, Vermeulen, R. & Dekker, H. (2009), On-road NO<sub>x</sub> emissions of Euro-V truck, TNO report.
- Ligterink, N.E., Kadijk, G., Mensch, P. van (2012), Determination of Dutch NO<sub>x</sub> emission factors for Euro-5 diesel passenger cars, TNO report.
- Ligterink, N.E., Kadijk, G., Mensch, P. van, Hausberger, S., Rexeis, M., (2013) Investigations and real world emission performance of Euro 6 light-duty vehicles, TNO report.
- Ligterink, N.E., Stelwagen, U. & Kuenen, J.P.P. (2014), Emission factors for alternative drivelines and alternative fuels, TNO 2014 R11309, Utrecht: TNO.
- Ligterink, N.E. (2015), Composition and payload distribution of the on-road heavy-duty fleet in the Netherlands, TNO 2016 R10040, Utrecht: TNO.
- Ligterink, N. (2016), On-road determination of average Dutch driving behavior for vehicle emissions, Delft: TNO.
- Ligterink, N. (2017a), Elemental carbon emission factors of vehicles for Dutch air-quality assessments, Delft:TNO report R10517. Ligterink, N. (2017b), The fleet composition on the Dutch roads relevant for vehicle emissions, Delft:TNO.
- Ligterink, N.E. et al. (2019), Emissiefactoren wegverkeer. Actualisatie 2019, TNO report R10825.
- Ligterink, N.E., Kadijk, G., Elstgeest, M. Van Mensch, P. (2019), Emission compliance over the lifespan of a vehicle, Transport and Air Pollution Conferene in Thessaloniki, Greece, 15-17 May 2019, 1-9.
- Ligterink, N.E., et al. (2021a), High NO<sub>x</sub> emissions of heavy-duty vehicles driving in urban areas and directions for a real driving emissions test, 2021-STL-MEM-100342761.
- Ligterink, N.E., Geilenkirchen, G., Van Eijk, E., De Ruiter, J.M. (2021), Emissiefactoren wegverkeer, TNO report R11981.
- Machrafi, H. & W. Mertens (1999), Verslag van het onderzoek naar het benzeen (benzene survey report), studentverslagen TU Eindhoven (Technical University).
- Molnár-in 't Veld, H. & Dohmen-Kampert, A. (2011), Verkeersprestaties autobussen; methodebeschrijving en resultaten, Statistics Netherlands, Den Haag/Heerlen.
- Molnár-in 't Veld (2014), Onderzoeksmethode berekenen verkeersprestaties van personenauto's, Statistics Netherlands, Den Haag/Heerlen.
- Molnár-in 't Veld, H., Sijstermans, M., Staats, K., et al. (2014), Methodologisch rapport verkeersprestaties motorfietsen en bromfietsen, Statistics Netherlands (CBS), Den Haag/Heerlen.
- Riemersma, I.J. & Smokers, R. (2004), Ontwikkeling van het Versit+ HD emissiemodel, TNO, Delft.
- Roovaart, J.van den (2000), Notitie over gebruik van ZOAB t.b.v. taakgroep Verkeer (memo about the use of porous asphalt), RIZA.
- Ruiter, J.M. de & Van Mensch, P. (2022), Analysis of the emission performance of the vehicles tested for the Green Vehicle Index (GVI) project, TNO report R10798.
- Ruiter, J. M. de, R. N. van Gijlswijk, and N. E. Ligterink (2019), More Information, Less Emissions - Estimating the Real-World CO<sub>2</sub> Emissions of Passenger Cars Based on Vehicle Properties : TNO, 2019. — TNO 2019 R10872

- Ruiter, J. M. de, R.N. van Gijlswijk and N.E. Ligterink (2021), Model M1: estimation of the real-world CO<sub>2</sub> emissions of passenger cars based on vehicle properties, LIFE-MILE<sub>21</sub> Deliverable D C3.1 version 2.
- RWS (2008), Remslijtage, Versie juni 2008, Rijkswaterstaat – Waterdienst in samenwerking met DELTARES en TNO.
- Shell (2000), Technical information on Shell Pura, Department of Technical Support Fuels, 2000/CSS/086.
- Spreen, J.S., G. Kadijk, R.J. Vermeulen, V.A.M. Heijne, N.E. Ligterink, U. Stelwagen, R.T.M. Smokers, P.J. van der Mark & G. Geilenkirchen (2016), Assessment of road vehicle emissions: methodology of the Dutch in-service testing programmes, TNO 2016 R11178, TNO, Delft.
- Staats, K., Molnár-in 't Veld, H., Willems, R. & Ligterink, N. (2014), Bottom-up berekening CO<sub>2</sub> personenauto's (in Dutch). Statistics Netherlands (CBS), Den Haag/Heerlen.
- Stelwagen, U. & Ligterink, N.E. (2015a), NH<sub>3</sub> emission factors for road transport, TNO 2015 R11005, Utrecht: TNO.
- Stelwagen, U. & Ligterink, N.E. (2015b), HD Euro-V Truck PM<sub>10</sub> and EC emission factors, TNO 2015 R11041, Utrecht: TNO.
- Ten Broeke, H., Hulskotte, J. & Denier van der Gron, H. (2008), Emissies door bandenslijtage afkomstig van het wegverkeer, Rijkswaterstaat Waterdienst.
- Ten Broeke, H.M. & Hulskotte J.H.J. (2009), Actuele VOS- en PAK-profielen van wegverkeer, TNO-034-UT-2009-00604\_RPT-ML.
- UNECE (2014), Guidelines for reporting emissions and projections data under the convention on long-range transboundary air pollution. Prepared by the task force on emission inventories and projection.
- uCARe D1.2. Elstgeest, M., et al., Augmented emission maps, H2020 project deliverable.
- Van Zyl, P.S., Ligterink, N.E., Kadijk, G., Borken-Kleefeld, J. & Chen, Y. (2015a), In-use compliance and deterioration of vehicle emissions, TNO 2015 R11043, Utrecht: TNO.
- Van Zyl, P.S., P. van Mensch, N.E. Ligterink, R. Dröge & G. Kadijk (2015b) Update emission model for two-wheeled mopeds, TNO 2014 R11088, Utrecht: TNO.
- Velders, G.J.M., J.M.M. Aben, W.F. Blom, H.S.M.A. Diederens, G.P. Geilenkirchen, B.A. Jimmink, A.F. Koekoek, R.B.A. Koelemeijer, J. Matthijsen, C.J. Peek, F.J.A. van Rijn, M.W. van Schijndel, O.C. van der Sluis en W.J. de Vries (2009), Concentratiekaarten voor grootschalige luchtverontreiniging in Nederland. Rapportage 2009, Bilthoven: Planbureau voor de Leefomgeving.
- Vermeulen, R.J. & W.A. Vonk, (2013), On-road emission measurements with PEMS on a heavy-duty truck with a retrofit dual-fuel system, using diesel and CNG, R10623.
- Vermeulen, R.J., N.E. Ligterink & P.J. van der Mark (2021), Real-world emissions of non-road mobile machinery, The Hague: TNO.
- Vermeulen, R.J. et al. (2021), Dutch In-service emissions testing programme for heavy-duty vehicles 2019-2020, TNO report R10121.
- Vermeulen, R.J. et al. (2022), Dutch In-service Emissions Measurement and Monitoring programme for Heavy-Duty vehicles 2021, TNO report R10375.
- VROM (1993), Publikatiereeks Emissieregistratie. Emissiefactoren Vluchtige organische stoffen uit verbrandingsmotoren, No. 10, april 1993, Den Haag.

Weilenmann, M. (2005), Impact of Air Conditioning on Emissions of Gasoline Euro-3 Passenger Cars – Preliminary Report, EMPA, Dübendorf.

Willems, R., Molnár-in 't Veld, H. & Ligterink, N. (2014), Bottom-up berekening CO<sub>2</sub> van vrachtauto's en trekkers (in Dutch). Statistics Netherlands (CBS), Den Haag/Heerlen, 2014.

## Chapter 4

Coenen, P.W.H.G. & J.H.J. Hulskotte (1998), Onderzoek naar de emissies naar oppervlaktewater van railverkeer in de provincie Zuid-Holland, rapportnr. TNO Built Environment and Geosciences-Rog8/Co1, TNO Built Environment and Geosciences, Apeldoorn.

CTO, 1993, Project koperemissie spoorwegverkeer (copper emissions by rail transport), part I, II en III, Dutch Rail (NS), Centrum voor Technisch Onderzoek, Utrecht

Dellaert, S.N.C. & R. Dröge (2017), Uncertainty of the NO<sub>x</sub>, SO<sub>x</sub>, NH<sub>3</sub>, PM<sub>10</sub>, PM<sub>2.5</sub>, EC<sub>2.5</sub> and NMVOC emissions from transport, TNO 2017 R10854, TNO, Utrecht.

Ligterink (2017) Insight into the energy consumption, CO<sub>2</sub> emissions and NO<sub>x</sub> emissions of rail freight transport, Ligterink et al. 2017.

Ntziachristos, L., Z. Samaras, 2000. COPERT III; Computer Programme to calculate emissions from road transport, methodology and emission factors (version 2.1), European Energy Agency (EEA), Copenhagen, November 2000.

RIVM/LAE (1993), Memo about information from Dutch Rail (NS) on emission factors for diesel powered trains, Bilthoven.

VRM (1993), Publikatiereeks Emissieregistratie. Emissiefactoren Vluchtige organische stoffen uit verbrandingsmotoren, No. 10, april 1993, Den Haag.

Hilster, D., L.C. den Boer, M.J.J. 't Hoen & M.B.J. Otten (2020) Review of Dutch rail diesel emissions calculation methodology, Delft: CE Delft.

Mensch, P. van, S. van Merriënboer, D. Tol, A. Rondaj, J. Harmsen and R. Fransen (2022) Inventarisatie en categorisatie huidige en toekomstige aanbod duurzame mobiele werktuigen, bouwlogistieke voertuigen, spoorwerktuigen en vaartuigen die worden ingezet voor de waterbouw, TNO 2022 R11048, TNO, Den Haag.

## Chapter 5

BLN – Schuttervaer (2017), Resultaten enquête vergroening en duurzaamheid binnenvaart (Results questionnaire about greening and sustainability inland shipping), 21 July 2017.

Bolt, E. (2003), EMS-protocol Emissies door Binnenvaart (emissions from inland navigation): Ontgassing van ladingdampen naar lucht (degassing of load vapours). Project Emissieregistratie en Monitoring Scheepvaart. Rijkswaterstaat, Adviesdienst Verkeer en Vervoer, (EMS project of Ministry of Waterways and public works) Rotterdam.

Bolt E. (2003), Schatting energiegebruik van binnenvaartschepen (energy consumption of inland vessels) versie 3, 22 oktober 2003

De Buck A., 't Hoen M. & den Boer E. (2013), Update estimate emissions degassing inland tank vessels, Delft: CE Delft.

Dellaert, S.N.C. & R. Dröge (2017), Uncertainty of the NO<sub>x</sub>, SO<sub>x</sub>, NH<sub>3</sub>, PM<sub>10</sub>, PM<sub>2.5</sub>, EC<sub>2.5</sub> and NMVOC emissions from transport, TNO 2017 R10854, TNO, Utrecht.

- Deltares & TNO (2016), Engine emissions from recreational boats (in Dutch).
- Hulskotte J., EMS-protocol Emissies door binnenvaart: verbrandingsmotoren (Emissions by inland navigation: combustion engines), versie 5, 20 November 2018.
- Hulskotte J.H.J.(2019), Handleiding ontgassingsmodel (OMO), TNO 2019 R12018, TNO Utrecht, 2019.
- Pouwels M., van der Spoel M., de Wit T., Verbetering huidig en toekomstig vaarwegennet met behulp van AIS data (Improvement of current en future waterway network by means of AIS data), CBS Heerlen 8 juni 2017
- Wijnbelt M., output of IVR database : TNO - 60028758.xlsx, 10 September 2014

## Chapter 6

- Dellaert, S.N.C. & R. Dröge (2017), Uncertainty of the NO<sub>x</sub>, SO<sub>x</sub>, NH<sub>3</sub>, PM<sub>10</sub>, PM<sub>2.5</sub>, EC<sub>2.5</sub> and NMVOC emissions from transport, TNO 2017 R10854, TNO, Utrecht.
- Hulskotte J.H.J, Brake ter M.C., Revised calculation of emissions of fisheries on the Netherlands territory, TNO report TNO 2017 R10784, 29 June 2017.
- Mike Turenhout, Katell Hamon, Hans van Oostenbrugge, Arie Mol en Arie Klok, Emission Dutch fisheries, indicators of fuel consumption on behalf of greenhouse gas calculations (in Dutch), Nota 2016-122, Wageningen Economic Research, Wageningen November 2016

## Chapter 7

- Chiffi F., Schrooten E. & de Vlieger I. (2007), EX-TREMIS - Exploring non road Transport Emissions in Europe – Final Report. IPTS - Institute for Prospective Technological Studies. DG-JRC.
- Dellaert, S.N.C. & R. Dröge (2017), Uncertainty of the NO<sub>x</sub>, SO<sub>x</sub>, NH<sub>3</sub>, PM<sub>10</sub>, PM<sub>2.5</sub>, EC<sub>2.5</sub> and NMVOC emissions from transport, TNO 2017 R10854, TNO, Utrecht.
- Grose I. & Flaherty, J. (2007), LNG Carrier Benchmarking. LNG15 2007. Shell Global Solutions International BV.
- Hulskotte, J.H.J. & Matthias V. (2013), Survey of fuel consumption of seagoing tankers at berth in Rotterdam, TNO 2013 R11287.
- Hulskotte, J.H.J., Wester, B., Snijder A.M. & Matthias V. (2013), International survey of fuel consumption of seagoing ships at berth, TNO 2013 R10472.
- IPCC (2006), 2006 IPCC Guidelines for National Greenhouse Gas Inventories, Prepared by the National Greenhouse Gas Inventories Programme, Eggleston, H.S., Buendia, L., Miwa, K., Ngara, T. and Tanabe, K. (eds). Published: IGES, Japan.
- Lloydsdatabase (IHS, 2018) IHS Maritime World Register of Ships.
- MARIN (2019 in prep), Sea shipping emissions 2016: Netherlands Continental Shelf, 12- mile zone and port areas, Wageningen: MARIN.
- Ntziachristos, L., Z. Samaras, 2000. COPERT III; Computer Programme to calculate emissions from road transport, methodology and emission factors (version 2.1), European Energy Agency (EEA), Copenhagen, November 2000.
- Schouten, D.R., Hasselaar, T.W.F., Ship emission model validation with noon reports, MARIN Report No. 30799-1-TM, 24 August 2018.
- Cooper, D.A., HCB, PCB, PCDD and PCDF emissions from ships, Atmospheric Environment 39, 4901-4912, 2005

## Chapter 8

- AFS. (2013). *HESSQ jaarverslag 2012. Aircraft Fuel Supply B.V.*
- Amsterdam Airport Schiphol. (1990, 1995 - 2004). *Statistical Annual Review*. Amsterdam.
- CBS. (2020a). *Luchtvaart; maandcijfers Nederlandse luchthavens van nationaal belang*. Retrieved June 2020, from CBS Statline: <https://opendata.cbs.nl/statline>
- CBS. (2020b). *Luchtvaart; vliegtuigbewegingen op kleine luchthavens*. Retrieved June 2020, from CBS Statline: <https://opendata.cbs.nl/statline>
- CBS. (2020c). *Vliegbewegingen per ICAO type Nederlandse vliegvelden*.
- Dellaert, S.N.C. & J.H.J. Hulskotte (2017), Emissions of air pollutants from civil aviation in the Netherlands, TNO 2017 R10055, TNO, Utrecht.
- Dellaert, S.N.C. & R. Dröge (2017), Uncertainty of the NO<sub>x</sub>, SO<sub>x</sub>, NH<sub>3</sub>, PM<sub>10</sub>, PM<sub>2.5</sub>, EC<sub>2.5</sub> and NMVOC emissions from transport, TNO 2017 R10854, TNO, Utrecht.
- EMEP/EEA. (2016). *Air pollutant emission inventory guidebook. NFR 1.A.3.a*. Copenhagen: EEA.
- Euroncontrol (2020). *Annual taxi times Dutch Airports 2005-2019*. Euroncontrol Central Office for Delay Analysis. August 7<sup>th</sup>, 2020
- Feldbrugge, P. (2018). *Personal communication in name of KES by email 26-05-2018*.
- FFA. (1996). *Federal Aviation Air Emissions Databank version 2.1*. Bromma: Aeronautical Research Institute of Sweden.
- Helsen, J. (2020). *Afzet AvGas UL91 op Lelystad Airport*. Personal communication. September 4<sup>th</sup> 2020.
- ICAO. (2011). *Airport air quality manual*. Montreal: ICAO.
- ICAO. (2020). *DOC 8643 - Aircraft type designators*. Retrieved June 2020, from [https://cfapp.icao.int/Doc8643/reports/Part2-By%20Type%20Designator\(Decode\).pdf](https://cfapp.icao.int/Doc8643/reports/Part2-By%20Type%20Designator(Decode).pdf)
- ICAO. (2020). *Engine exhaust emissions data bank*. Paris: <https://www.easa.europa.eu/document-library/icao-aircraft-engine-emissions-databank>.
- ICAO. (several years). *International standards and recommended practices environmental protection, Annex 16 to the convention on international civil aviation. First edition 1981*. Paris: International Civil Aviation Organisation.
- KLM. (2016). *APU emission factors*. Amsterdam: KLM.
- Ministerie van Infrastructuur en Milieu. (2016). *Luchtvaartuigregister Nederland*.
- Morris, K. (2007). *Emissions from Aircraft; Airframe sources; Tyre and brake wear*. British Airways.
- Netcen. (2004). *Revision to the Method of Estimating Emissions from Aircraft in the UK Greenhouse Gas Inventory*. Abingdon.
- Nollet. (1993). *Taxi times for PMMS-working party 4 (revised version)*. Amsterdam: NV Schiphol Airport, AOM93/025.RH.
- Rindlisbacher et al., T. (2007). *Aircraft piston engine emissions*. Bern: Swiss Federal Office of Civil Aviation (FOCA).

- Rindlisbacher, T. (2009). *Guidance on the determination of helicopter emissions*. Federal Office Of Civil Aviation (FOCA), Swiss Confederation, Reference: o/ 3/33/33-05-20.
- Speth, R.L., Agarwal, A., Fritz, T.M., Jacob, S.D., Rindlisbacher, T., Iovinelli, R., Owen, B., Miake-Lye, R.C., Sabnis, J.S., Barrett, S.R., *SCOPE11 Method for Estimating Aircraft Black Carbon Mass and Particle Number Emissions*. Environ. Sci. Technol. 2019, 53, 1364–1373
- UK Civil Aviation Authority (2010), ICAO Engine Emissions Databank, updated December 2010.
- US EPA. (1985). *AP-42 Compilation of air pollution emission factors, volume 2, Mobile sources, 4th edition*. Triangle park: United States Environmental Protection Agency.
- Visschedijk, A., Appelman, W., Hulskotte, J., & Coenen, P. (2007). *Onderhoud van methodieken Emissieregistratie 2006 - 2007*. Apeldoorn: TNO.

## Chapter 9

- Dellaert, S.N.C. (2016), *Emissions of mobile machinery at Dutch container terminals*, TNO, Utrecht.
- Dellaert, S.N.C. & R. Dröge (2017), *Uncertainty of the NO<sub>x</sub>, SO<sub>x</sub>, NH<sub>3</sub>, PM<sub>10</sub>, PM<sub>2.5</sub>, EC<sub>2.5</sub> and NMVOC emissions from transport*, TNO 2017 R10854, TNO, Utrecht.
- Dellaert, S.N.C., van Mensch, P., Bhoraskar, A., van der Mark, P. (2021), *Eindrapport data onderzoek mobiele machines in Nederland*, TNO 2021 R11086, TNO, Den Haag.
- Dellaert, S.N.C. (2022), *EMMA / MEPHISTO versie maart 2022 gebruikershandleiding*, TNO report R12145.
- EEA (2019) *EMEP/EEA Emission Inventory Guidebook 2019*, European Environmental Agency, Copenhagen.
- Harvey, C., Carey, P. & Warila, J. (2003), *EPA's newest draft nonroad emission inventory model*, 12<sup>th</sup> International Emission Inventory Conference, San Diego, California.
- Helms, H. et al. (2010), *Aktualisierung des Modells TREMOD- Mobile Machinery (TREMOM-MM)*, UBA TEXTE 28/2010, Dessau-Rosslau.
- Hulskotte J.H.J. & Verbeek R. (2009), *Emissiemodel Mobiele Machines gebaseerd op machineverkoop in combinatie met brandstofafzet (EMMA)*, TNO-034-UT-2009-01782\_RPT-ML.
- Van Kempen, E., Deschle, N., van Ark, E.J., Elsgeest, M., Ahout, F. (2022), *Yard Emission monitoring for Sustainability: Real-world measurements and outlook on Connected Automated Transport development for yards*, TNO 2022 R11208.
- Lambrecht, U. et al. (2004), *Entwicklung eines Modells zur Berechnung der Luftschadstoffemissionen und des Kraftstoffverbrauchs von Verbrennungsmotoren in mobilen Geräten und Maschinen*, IFEU, Heidelberg.
- Ligterink, N., Louman, R., Buskermolen, E., Verbeek, R. (2018), *De inzet van bouwmachines en de bijbehorende NO<sub>x</sub>- en CO<sub>2</sub>-emissies*, TNO 2018 R10465.
- Okkerse, W.J.H. & de Gier, C.W. (2010), *Stikstofoxidenemissies van containerterminals, droge bulk bedrijven en bouwplaatsen in de Rotterdamse haven*, Rotterdam: DCMR.
- Pulles T., Denier van der Gon H., Appelman W., Verheul M. (2012), *Emission factors from diesel and petrol used in European vehicles*, Atmospheric Environment 61, 641-651.